

PRACTICAL ANTENNA DESIGN

140-150 MHz
VHF TRANSCEIVERS

Online Edition

PRACTICAL ANTENNA DESIGN

**140-150 MHZ
VHF TRANSCEIVERS**

Online Edition

ELPIDIO LATORILLA

LEDF Media

Published by LEDF Media.

*COPYRIGHT, 2000 by
Elpidio Latorilla*

First Year of Publication, 2000

All rights reserved.

*No part of this book may be
reproduced in any form or by
any means, except brief quotations
for a review without permission
in writing from the Author.*

DEDICATION

This book is sincerely dedicated to the memories of
Ricardo, Mimi, Nida and Poloy
who
through their examples
taught me how to be responsible, strong and steadfast
for what one aspires for.
To them I give my deepest respect.
They died but their ideals will survive...

TABLE OF CONTENTS

	INTRODUCTION.....	6
1	GROUNDPLANE ANTENNA Model FA-2.....	7
2	GROUNDPLANE ANTENNA Model FQ-2.....	15
3	GROUNDPLANE ANTENNA Model FC-2.....	26
4	J-FED HALFWAVE ANTENNA Model JF-2.....	36
5	COAXIAL DIPOLE Model Cd-2.....	48
6	DIPOLE ANTENNA (gamma fed) Model DP-2F.....	60
7	QUAD LOOP ANTENNA Model QA-2F.....	75
8	DISCONE ANTENNA Model CD-2W.....	85
9	DISCONE ANTENNA Model CD-2P.....	99
10	DISCONE ANTENNA Model CD-2T.....	105
11	5/8 WAVE ANTENNA Model WA-2.....	116
12	5/8 WAVE ANTENNA Model WD-2.....	131
13	5/8 WAVE ANTENNA Model PF-2C.....	139
14	COLLINEAR ANTENNA Model SD-22.....	151
15	STACKED DIPOLE ARRAY Model SD-24.....	158
16	YAGI-UDA ANTENNA Model YG-23.....	162
17	MULTI-ELEMENT YAGI-UDA ANTENNA ARRAY.....	169
18	STACKING YAGI ANTENNAS.....	172
19	FORMULAS FOR CONVERTING ANTENNA DESIGNS FOR OTHER FREQUENCY BANDS.....	175
	ANSWERS TO REVIEW QUESTIONS.....	186
	APPENDIX.....	194
	GLOSSARY OF ANTENNA TERMS.....	196
	BIBLIOGRAPHY.....	200

INTRODUCTION

This book is one of a series designed to help anyone who wants to construct antennas for radio transceivers but who has only a basic knowledge in radio-communications technology. The approach applied in this book is similar to the do-it-yourself methods of trade books and theories are kept to a minimum. Detailed illustrations are extensively used throughout the whole process of antenna construction to simplify the otherwise difficult to comprehend technical jargon.

The antenna designs presented here are specifically cut to the dimensions necessary for proper operation in 140-150 MHz VHF band. Each chapter deals with a particular design and an extra chapter at the last part is added to help the constructor in converting the given antenna dimensions for other frequencies. However, the formulas for conversion give only a generalized information and much of the fine-tuning of the new dimensions is left to the actual experimentation of the constructor. A highly detailed no-guessing antenna dimensions for other frequency bands are described in other books in this series written by the author.

The choice of a certain design for a particular application is left to the decision of the constructor. In selecting a design, certain factors like portability, ruggedness, compactness, signal gain versus size, weight, wind loading and availability of materials must be taken into account to realize an optimum performance from a particular antenna.

The author assumes that the interested constructor has already some experience in basic construction techniques related to radiocommunications equipment installation like soldering VHF connectors to coaxial cables, making a pig tail, cutting aluminum tubes and using an SWR meter. Obviously a knowledge in operating a VHF transceiver is the most important.

Here is one rule of a thumb in installing VHF antennas: If you use an RG-58/U coaxial cable to feed the antenna, do not use more than 20 meters or 60 feet long. More than this length, much of the signal (almost half) is lost in the cable and will substantially degrade your antenna's performance. If it is unavoidable to extend this length, use the larger RG-8/U cable instead. Although this cable is about four times more expensive than RG-58/U cable, this is the only way you can avoid signal losses in the cable.

It is the author's hope that this book will provide adequate information to anyone wishing to build his own antennas for VHF tranceivers.

1 GROUNDPLANE ANTENNA

Model FA-2

Reliable communications in radio systems depends upon the over-all effectiveness of both the base station and mobile unit antennas. The radiation pattern of the transmitted signal is extremely important since it must be transmitted and received in densely populated areas as well as over long distances. If you are situated in the center of a town or a city, omnidirectional pattern is best suited for you. Omnidirectional pattern is also the best choice when you do not know the exact direction or location of the station you are communicating with. Directive pattern is practical only if you know exactly which direction must the signal be beamed to, in order to maximize the transfer of RF energy. However, antennas with directive patterns are more complex in design and will be discussed in later chapters.

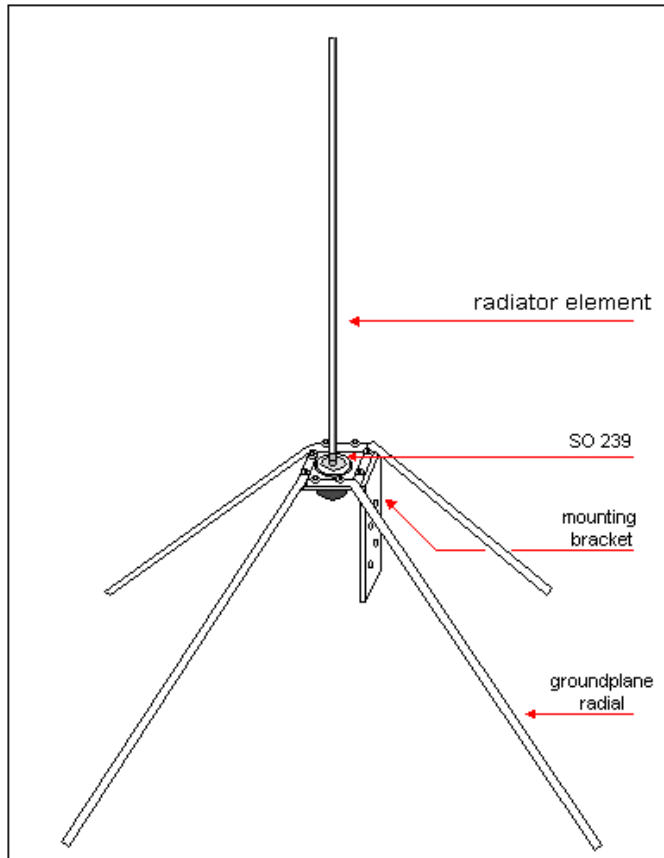

Generally, antennas for VHF bands are mounted as high off the ground as practical to overcome the limitations of the so called line-of-sight transmission and reception. An artificial ground must then be used since the antenna is well above the ground in this case. This is not a problem in automobiles since this artificial ground is provided by either the metal roof or body of the car. For tower installations however, some means must be provided to simulate this artificial ground. This is accomplished by the groundplane radials which are usually made of thin metal rods or tubes each cut to quarterwavelength long and mounted at the base of the antenna. The rods sometimes bend downward at an angle of about 45 degrees below the horizontal. This angle is important to maintain the correct impedance match of the system.

The ease of construction and low cost of a groundplane antenna makes it an ideal choice for VHF operators. The unit described in this chapter uses bronze rods for the radiating element because of their availability and a bronze rod is the easiest to connect to the center pin of the coaxial connector.

The groundplane radials are made of cheaper aluminum tubes. Obviously, the antenna is not easy to disassemble once completed so its use is commonly confined to fixed installations requiring little maintenance.

The operational frequency bandwidth of FA-2 is from 140 MHz up to 150 MHz exhibiting an SWR response of less than 1.5:1 over the entire bandwidth. It has a gain of 1 dB (unity gain) compared to a real dipole. Its signal pattern is omni-directional.

Figure 1.1 Groundplane antenna Model FA-2.

Materials List		
Quantity	Specification/Description	Dimensions
4	Aluminum Tubes	3/8 id x 20" each
1	Brass Rod - the brass rod for acetylene welding is recommended	1/8" diameter
1	SO-239 VHF female connector without flange	
8	Stove bolts - brass or stainless	1/8" x 3/4"
8	Lockwashers - brass, stainless or GI	1/8" id
8	Hex nuts - brass, stainless or GI	1/8" id
1	Aluminum plate gauge 14 or 16	2" x 6"
2	U-bolts with accompanying hex nuts and lockwashers	

*id - inside diameter

Construction

First of all construct the antenna mount. It is made from a 1/8" thick aluminum plate cut to 2" x 6". Drill a hole in the plate big enough for the SO-239 VHF connector to insert into (about 5/8" or 15.8 mm). Drill the hole at the point about 1" away from one end (see Figure 1.2).

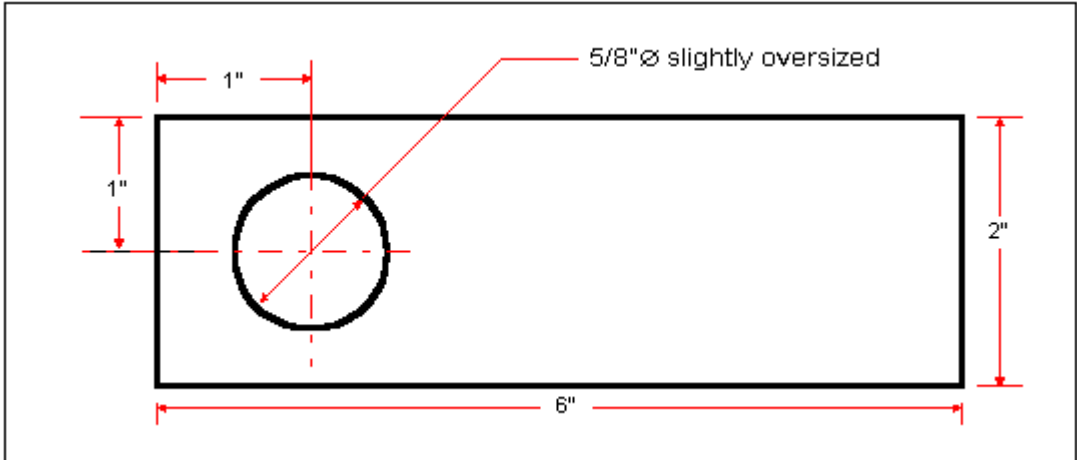

Figure 1.2 Antenna mount and hole Dimensions.

Next drill four holes at the other end of the plate following Figure 1.3 for the proper dimensions. Make sure that the distance between one pair of holes perpendicular to the length of the metal sheet must be the same with the distance of both ends of the U-bolt that will be inserted into it.

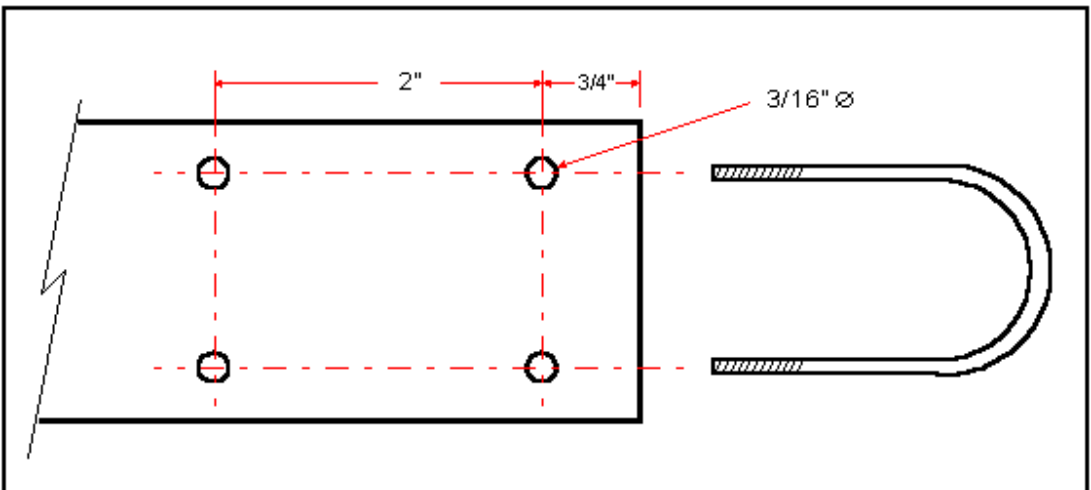

Figure 1.3 Hole dimensions for the U-bolts.

Next, drill eight holes (1/8" diameter) around the large hole following Figure 1.4 for the proper dimensions.

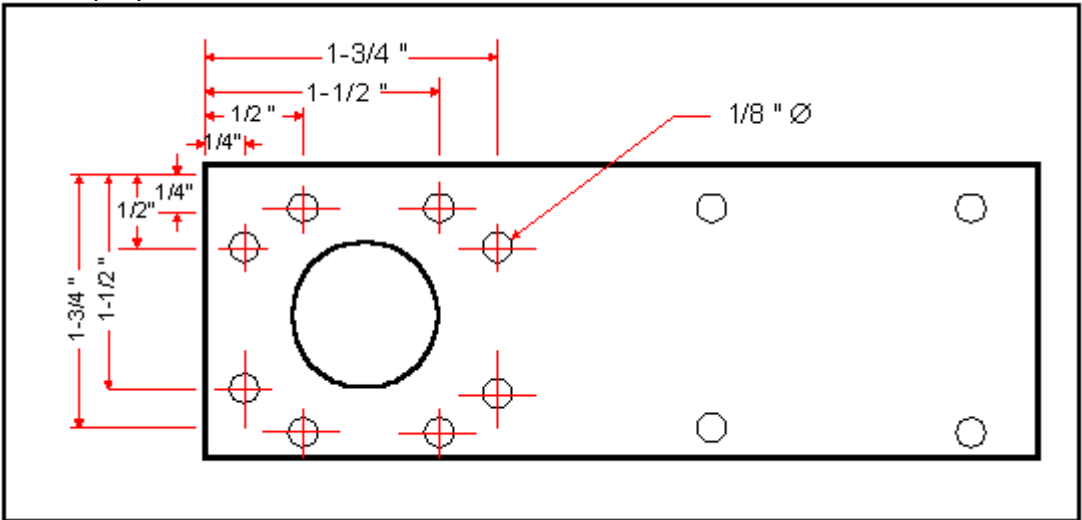

Figure 1.4 Hole dimensions for the radial elements around large hole.

Bend the aluminum plate down to a 90° angle (see Figure 1.5). Follow the illustration for the exact point to bend.

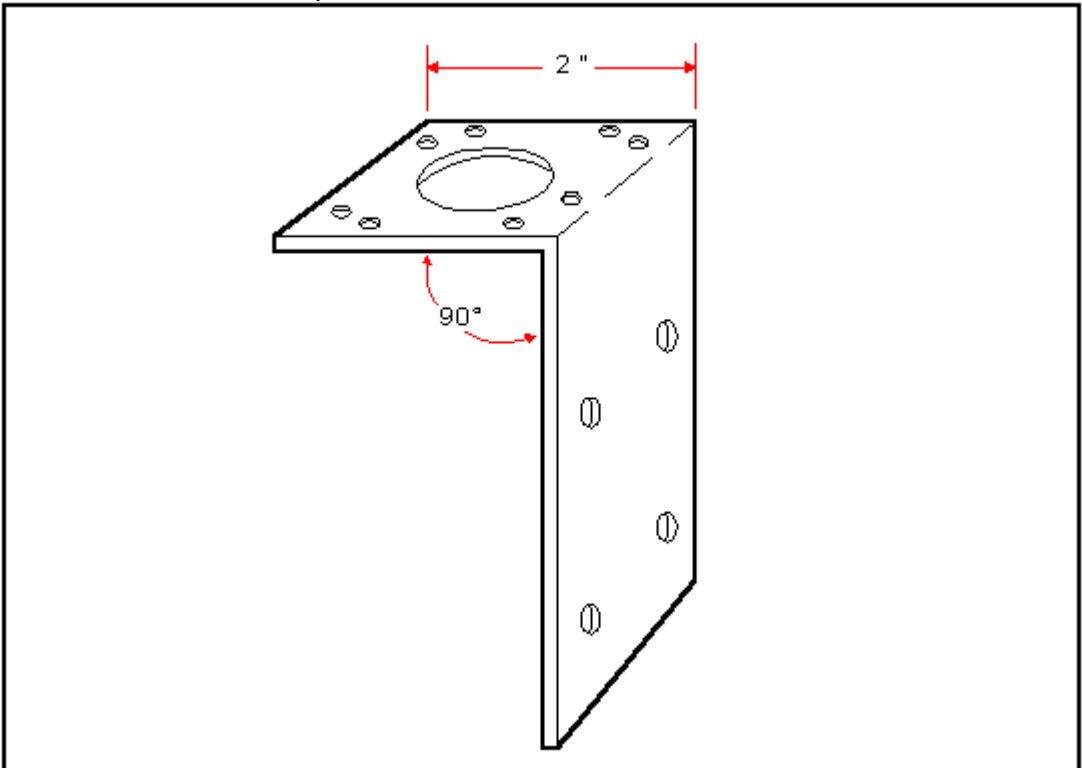

Figure 1.5 Bending the aluminum mounting plate.

Insert the SO-239 VHF connector facing downwards into the mounting plate and fix it permanently with its nut (see Figure 1.6). Discard the grounding ring/lug.

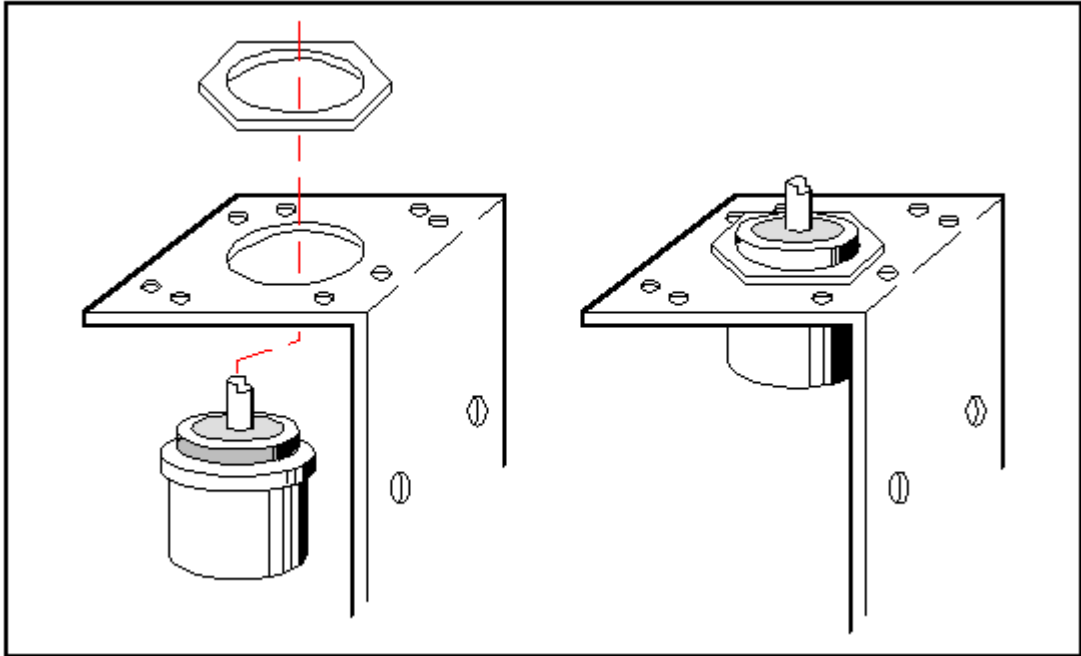

Figure 1.6 Mounting the SO-239 into the plate.

Cut the brass rod to a length of 19" (48.26 cm) and insert one of its end into the center pin of the SO-239 connector (see Figure 1.7). The brass rod may or may not fit into the center pin immediately, so you may need to file away a small portion at the end of the rod to reduce it to a smaller diameter.

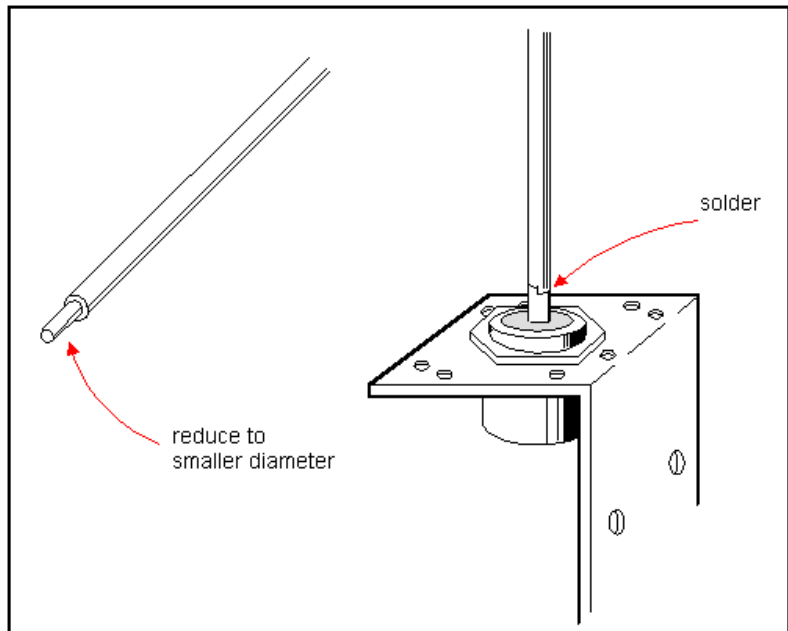

Figure 1.7 Preparing one end of the brass rod to fit inside the SO-239.

Cut four aluminum tubes to a length of 20" each and drill two holes (1/8" diameter) at one end (see Figure 1.8).

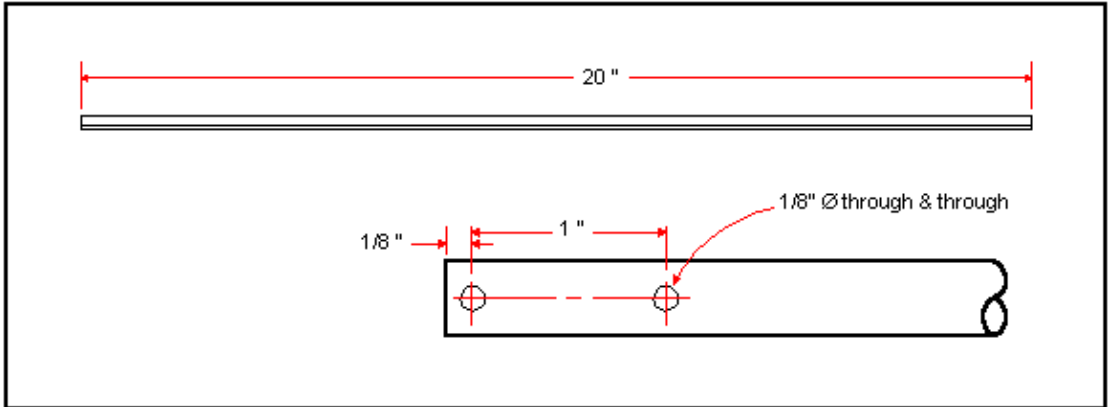

Figure 1.8 Preparing the tubes.

Bend the aluminum tubes to a 45 degree angle at the point 1 inch away for the end with two holes. The direction of the bend must be parallel with the axis of the drilled hole (see Figure 1.9).

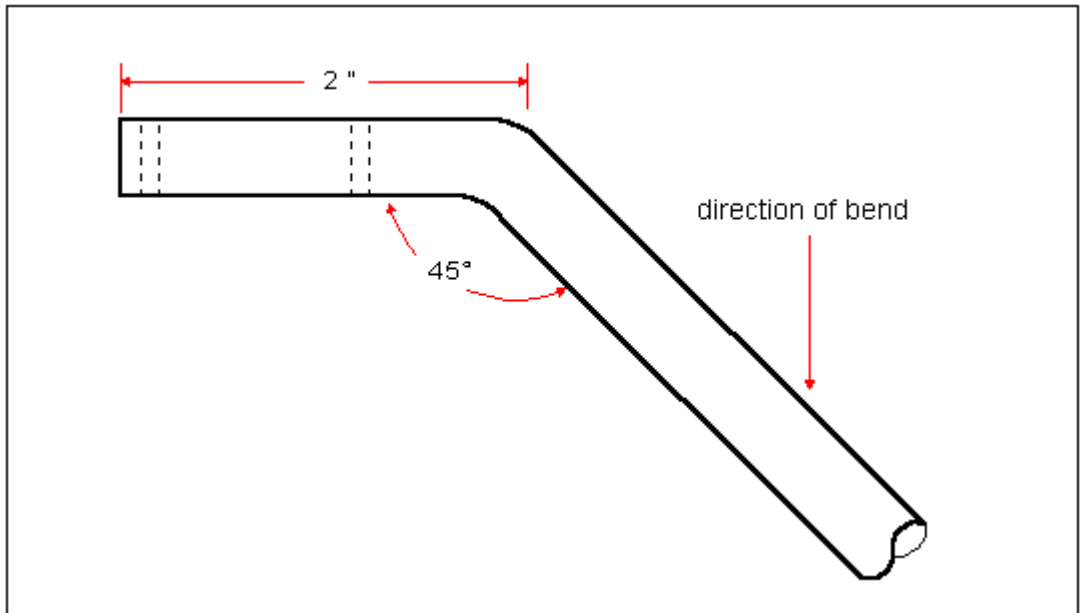

Figure 1.9 Bending the tubes.

Mount the four aluminum tubes into the angled plate by bolting each element with 1/8" x 3/4" stove bolts (see Figure 1.10). The stove bolts must be made of rust resistant material such as stainless steel, brass or GI.

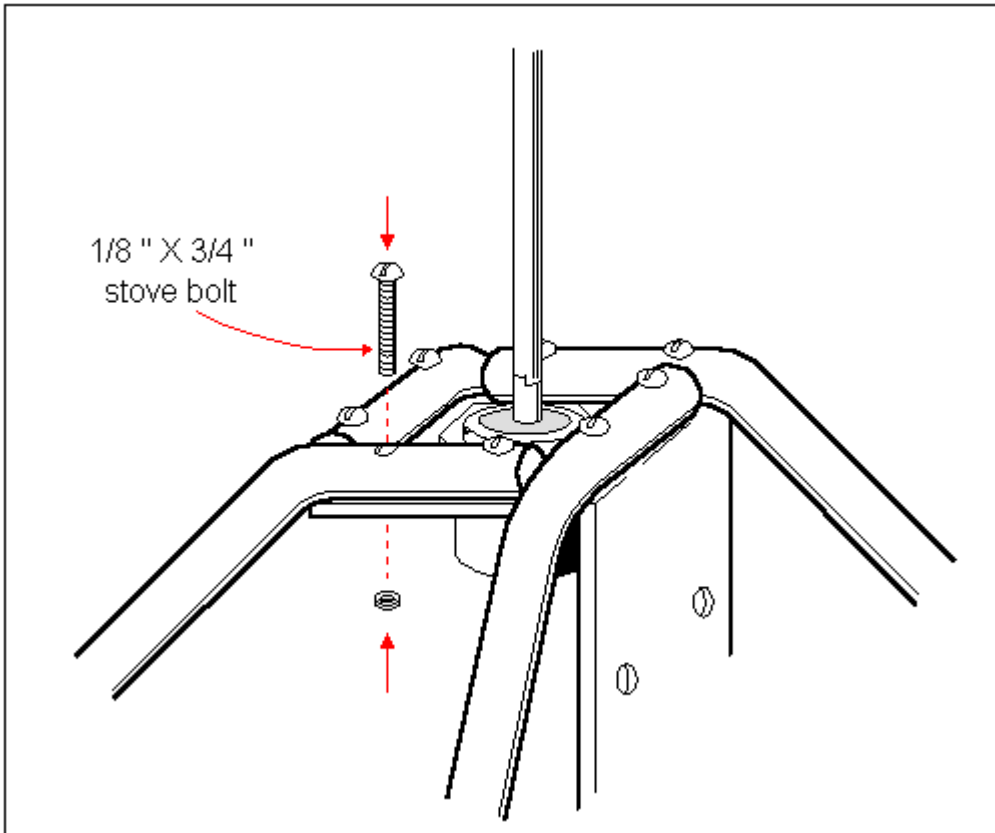

Figure 1.10 Mounting the tubes on the metal plate.

Finally , you can mount the antenna to the mast using the two U-bolts .

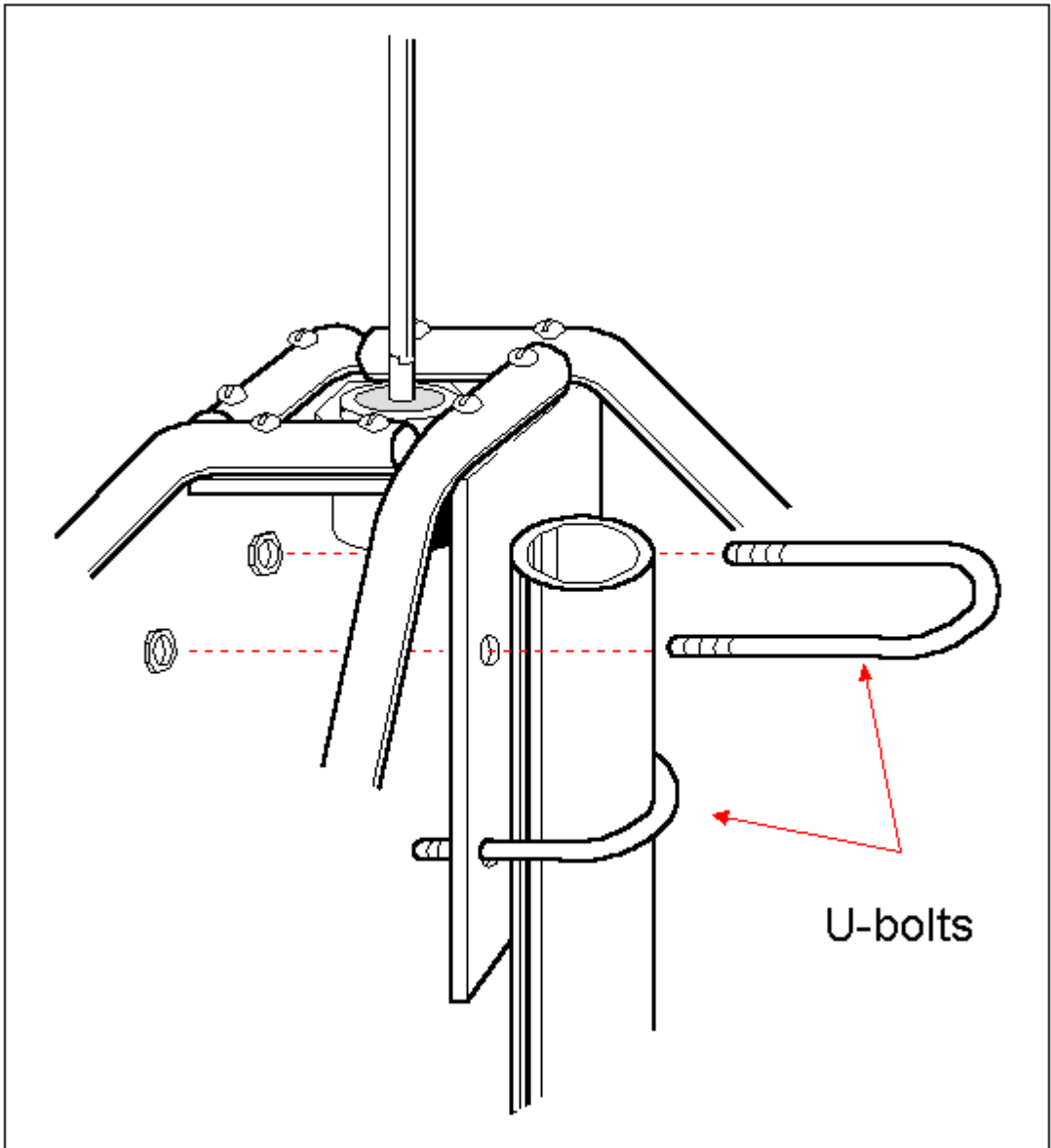

Figure 1.11 Mounting the antenna to the mast.

2 GROUNDPLANE ANTENNA

Model FQ-2

The antenna model FQ-2 is a development from the basic configuration of a groundplane. This unit features quick-detach elements to facilitate for easy and fast disassembly of the antenna. The total size of the antenna is much reduced when disassembled and becomes convenient to carry in transport. It is also a lot easier and faster to construct compared to the FA-2 design.

This particular version of the groundplane was evolved in an emergency situation where there were very few tools available. The place was aboard a fishing boat and there was no drilling tool around, so a groundplane design was created which did not require drilling of holes.

If you plan to use a groundplane in mobile operations, then this design is recommended. It can be easily inserted inside your backpack while you are travelling. Assembly or disassembly takes only a couple of minutes. The antenna elements are made of durable bronze materials so it can survive the stresses caused by the regular mounting and dismounting of the antenna. If you have accidentally bent an element, just straighten it and it is again functional. A slight bend or kink in the elements has no negative effects on the performance of the antenna. It is so durable that you have to intentionally cut it to pieces to destroy it. Experience has proven its reliability in the rugged life of mobile operations.

The electrical characteristics of this antenna are the same with those of model FA-2. The only difference between the two models is the mechanical construction and type of materials used.

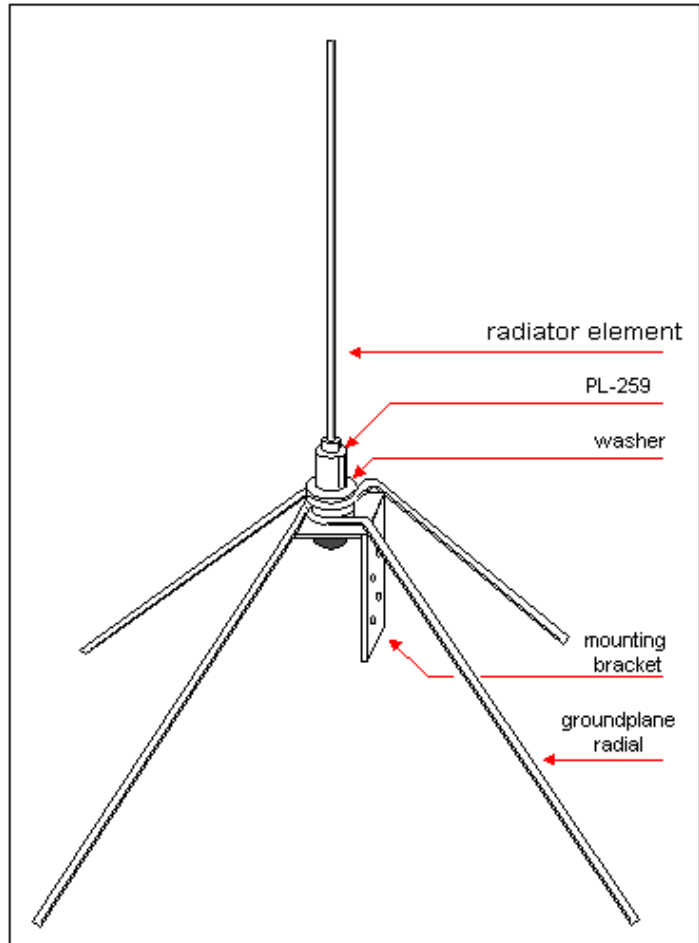

Materials List

Quantity	Specification/Description	Dimensions
5	Brass rods - the brass rod used for acetylene welding is recommended	1/8" diameter
2	PL-259 VHF male connectors	
1	PL-258 VHF straight connector	
1	Aluminum plate gauge 14 or 16	2" x 6"
2	U-bolts with accompanying hex nuts and lockwashers	
1	Plain washer GI or stainless steel	
1	short length of coaxial cable	2" long

Construction

Reduce one end of a brass rod to a smaller diameter enough to be inserted into the center pin of the PL-259 connector. File also a notch at its end as shown in Figure 2.1b. Insert the rod into the PL-259 and solder it to the center pin (see Figure 2.1c). File away any excess solder that is bulging out of the center pin.

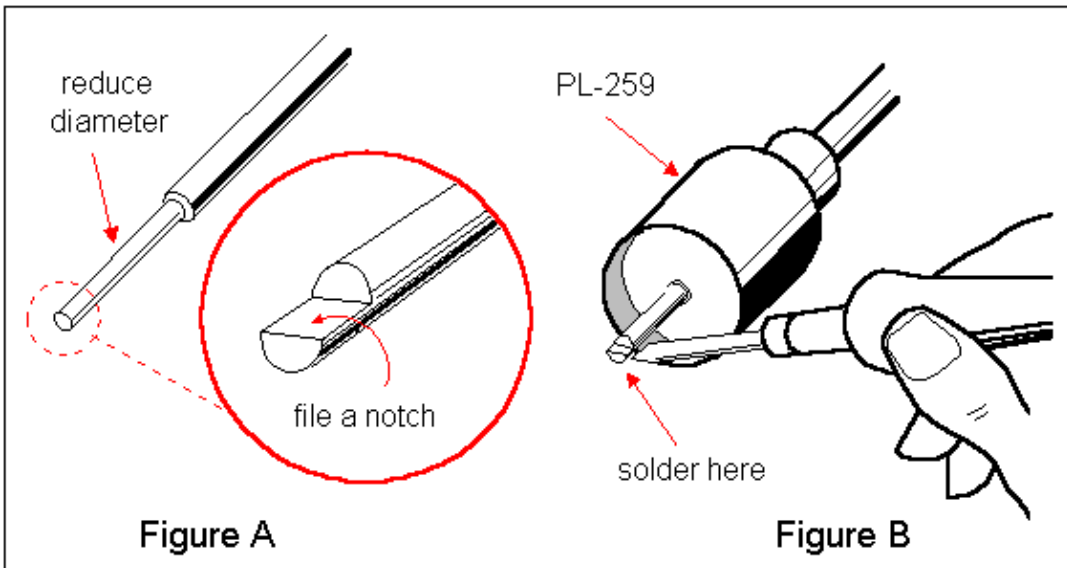

Figure 2.2 Preparing the end of a brass rod and soldering it to PL-259.

After soldering the rod into the PL-259 cut it to a length of 19" (48.26 cm) following Figure 2.3.

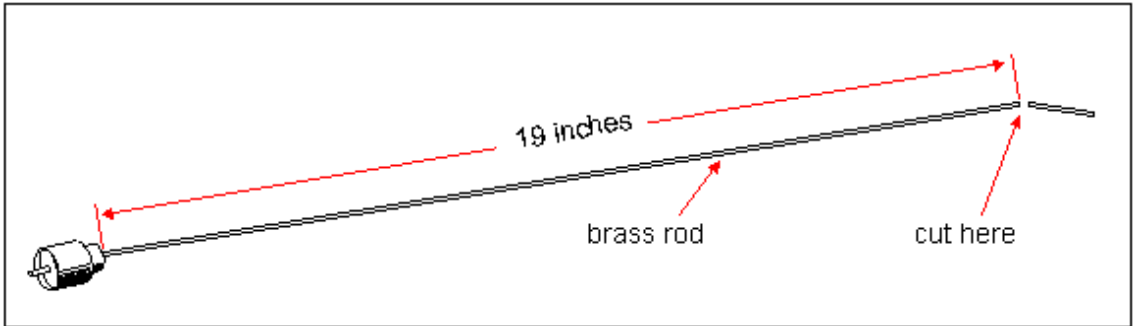

Figure 2.3 Trimming the rod to its proper length.

Cut a small piece of coaxial cable (about 2 inches) and remove its inner conductor and braid (shield). You will only need the vinyl outer jacket. Insert the vinyl jacket into the rod all the way inside the PL-259 (see Figure 2.4). Cut any protruding portion of the jacket. The vinyl jacket serves as an insulator between the brass radiator rod and the body of PL-259.

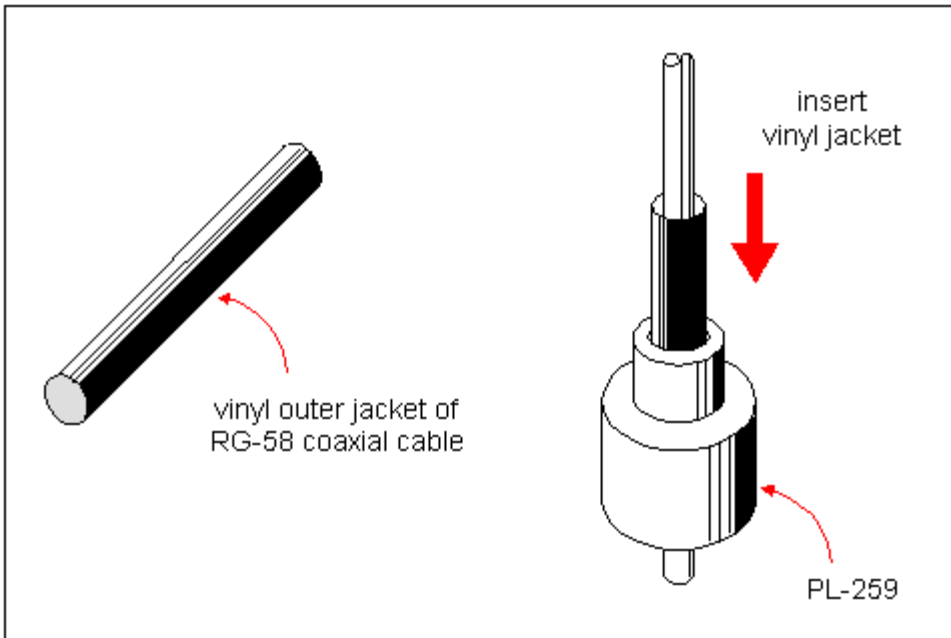

Figure 2.4 Inserting the vinyl insulator into the PL-259.

Prepare a small amount of epoxy glue and place it over the protruding portion of the vinyl insulator. The epoxy glue must cover the gap between the rod and the PL-259 to avoid the seepage of rainwater inside the connector. (Figure 2.5).

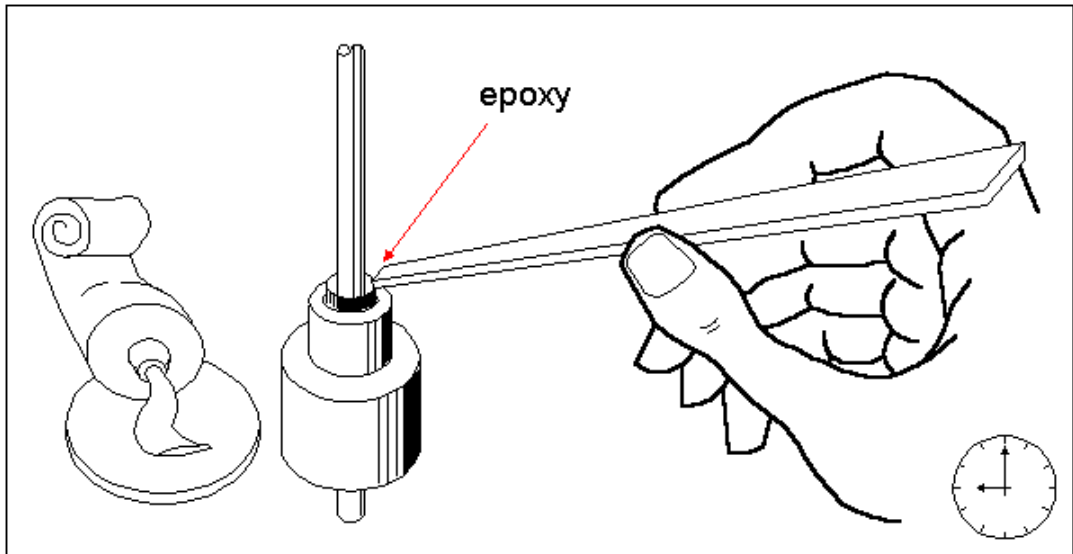

Figure 2.5 Sealing the gap with epoxy glue.

Next prepare the radial elements. Bend one end of each brass rod to an eyehook shape as shown in the following illustration (Figure 2.6). The diameter of the eyehook form must be dimensioned in such a way that the straight connector can be easily inserted into or pulled out of it.

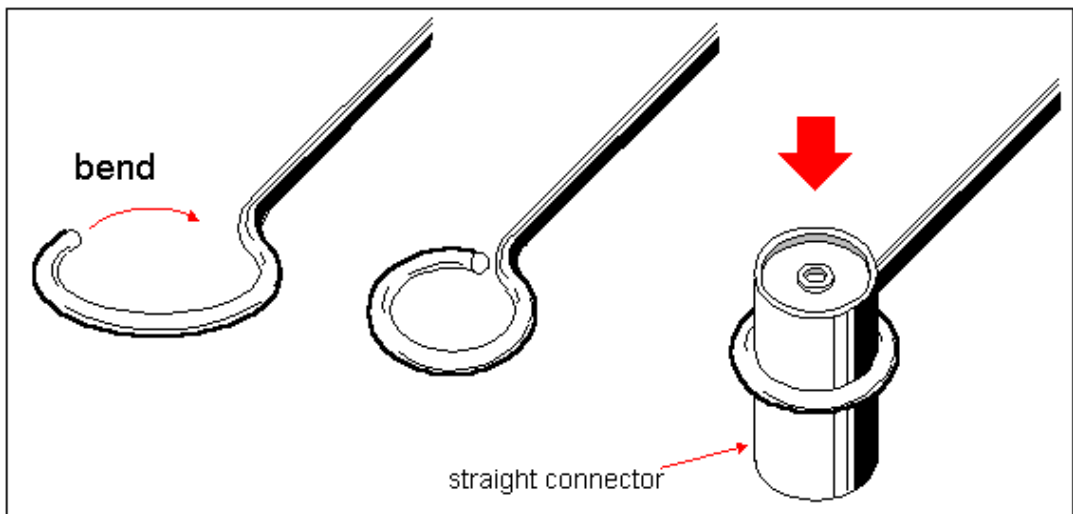

Figure 2.6 Shaping one end of the brass rods to an eyehook form.

After bending one end of all four brass rods into the necessary shape, measure 19 inches from the point where the rod starts to bend into the eyehook form. Mark the measured point at the other end and cut the brass rod at this point (see Figure 2.7).

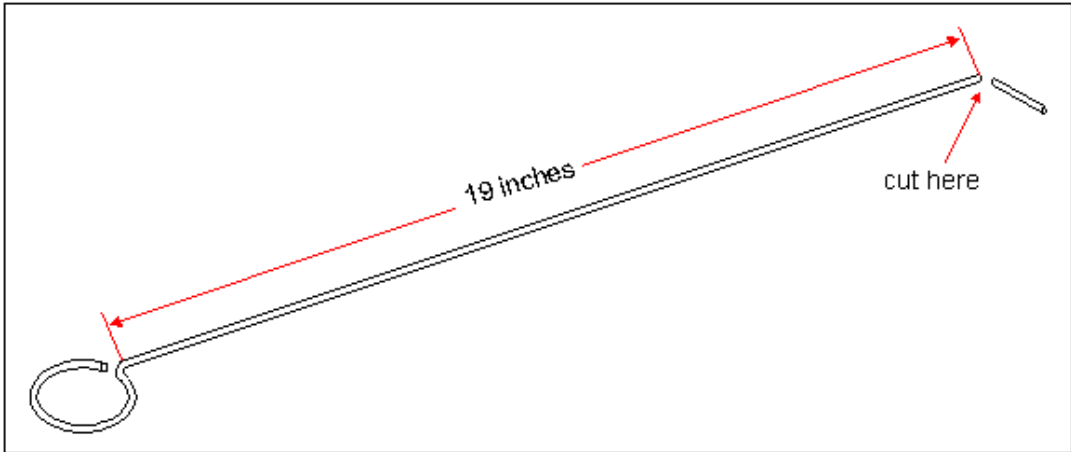

Figure 2.7 Trimming the radial rod to its proper length.

Next, bend the brass rods to a 45 degree angle (see Figure 2.8). Bend the rods at the point 1-1/4 inches away from the center of the eyehook form. The direction of the bend must be perpendicular to the plane of the eyehook end.

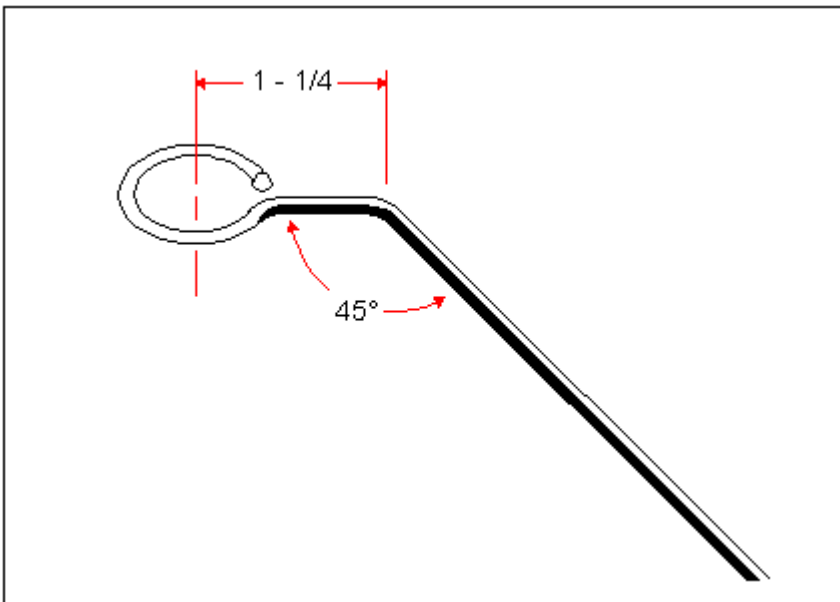

Figure 2.8 Bending the brass radial rod.

Solder the RG-58/U coaxial cable to the remaining PL-259 following the illustrated steps (see Figures 2.9 and Figure 2.10).

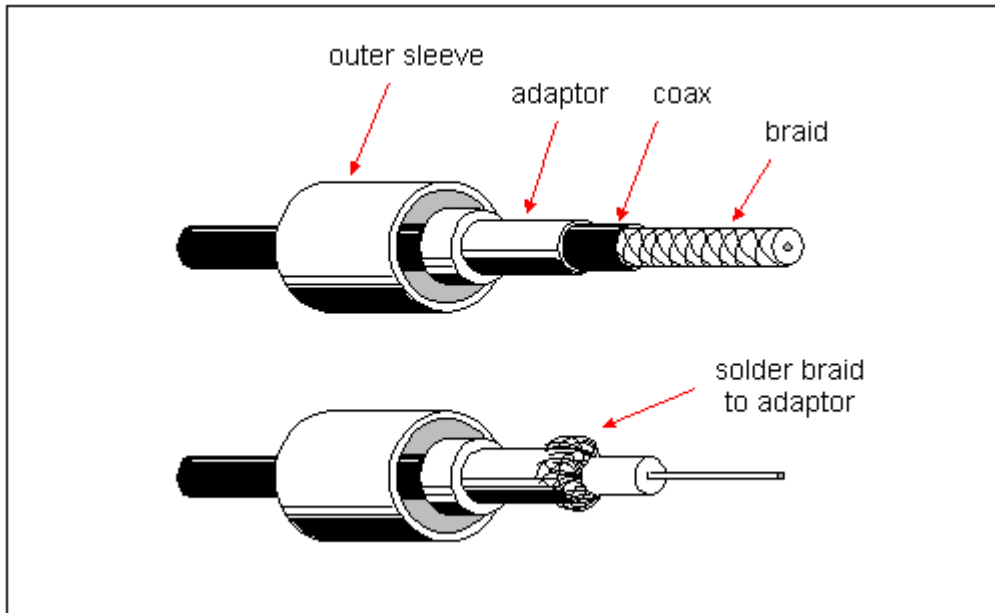

Figure 2.9 Connecting the coaxial cable to the PL-259.



IMPORTANT:

Check the coaxial cable for a possible short after soldering it to the PL-259 connector.

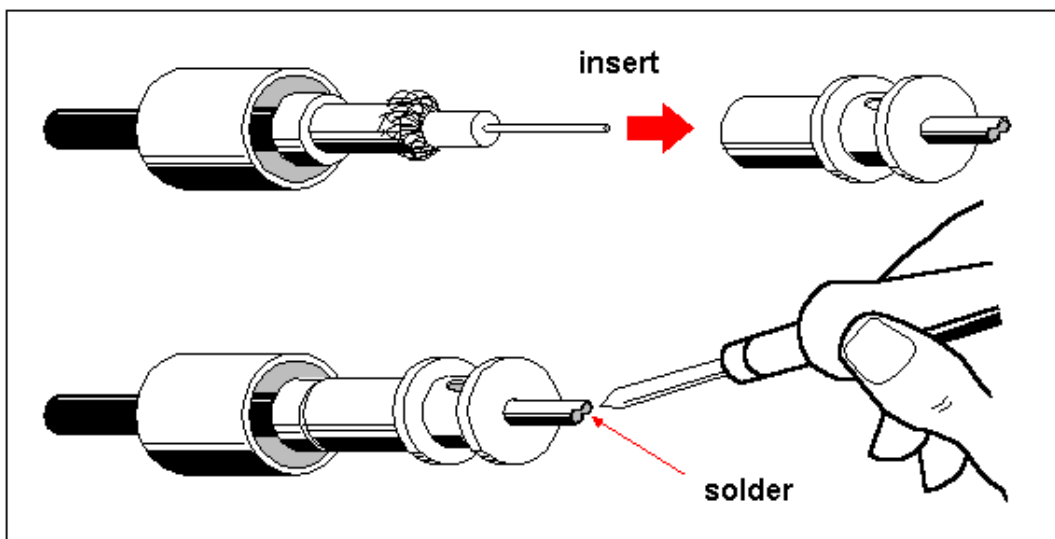

Figure 2.10 Assembling the PL-259.

The mounting bracket for Model FQ-2 is similar to that used for Model FQ-2. The only difference between the two is that the eight small holes around the 5/8" size hole are absent in the bracket for Model FQ-2 (see Figure 2.11).

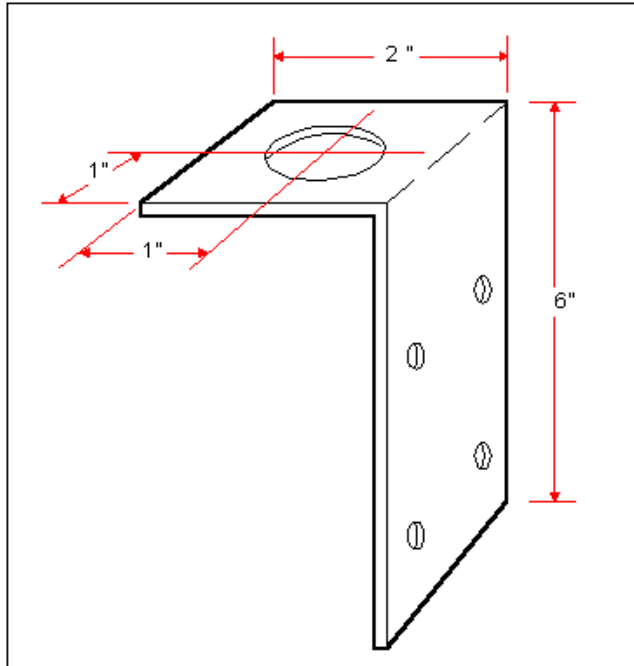

Figure 2.11 Mounting bracket for Model FQ-2.

Assembly

Attach the radiator element into the straight connector. Next, attach the plain washer (5/8" diameter) into the straight connector (see Figure 2.12).

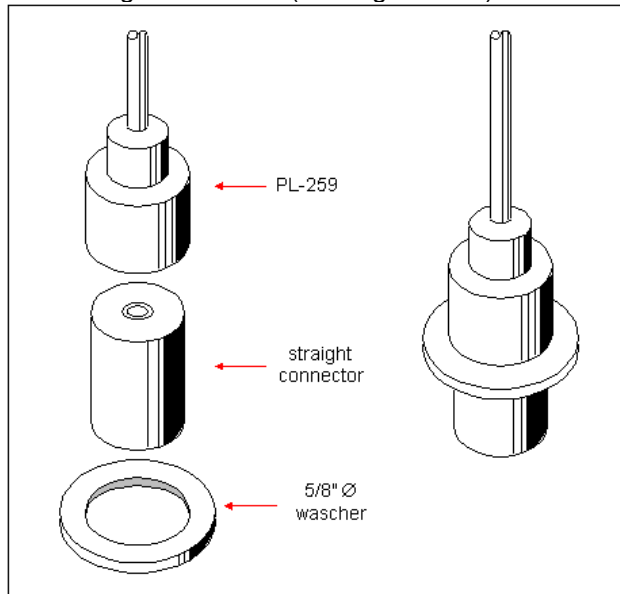

Figure 2.12 Assembling the radiator portion.

Insert the straight connector into the eyehook ends of the brass radial elements. The other ends of the elements must be sloping downwards (see Figure 2.13).

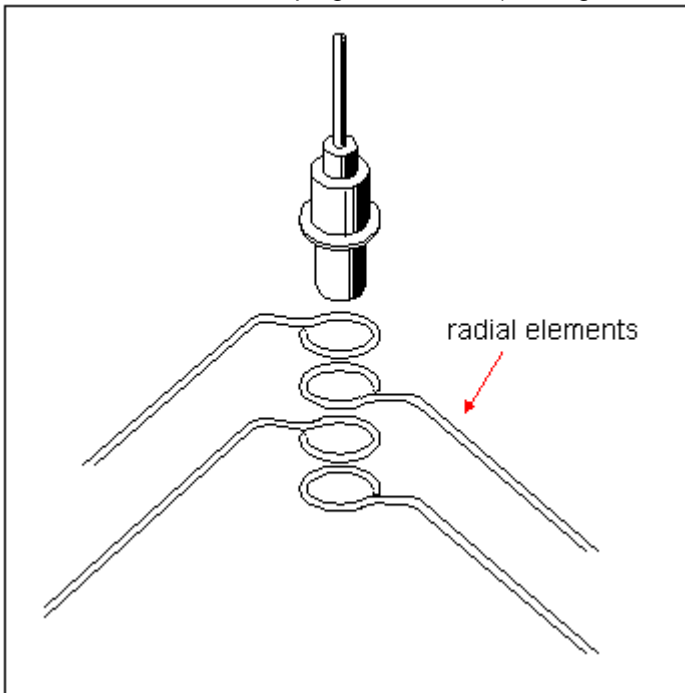

Figure 2.13 Assembling the radial elements into the antenna base portion.

Insert the remaining portion of the straight connector into the mounting bracket you made earlier sandwiching the radial elements between the bracket and the plain washer (see Figure 2.14). Secure the whole assembly by connecting the other PL-259 connector into the protruding part of the straight connector.

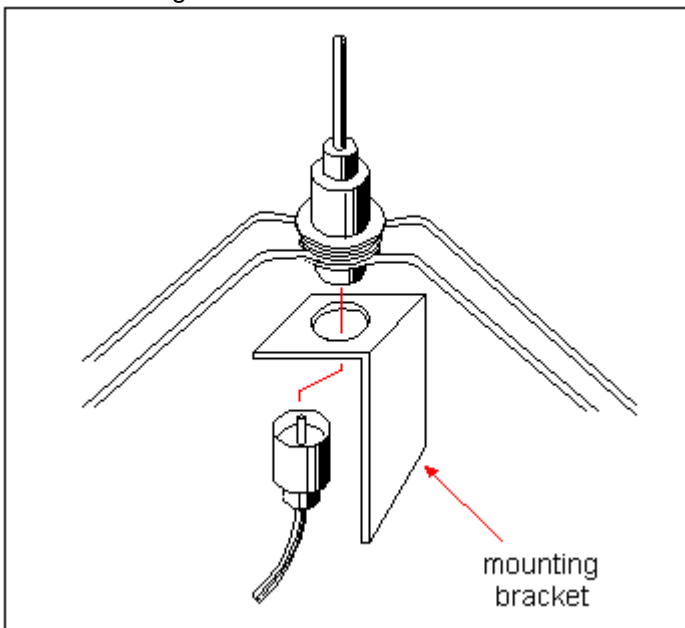

Figure 2.14 Assembling the antenna into the mounting bracket.

Installation

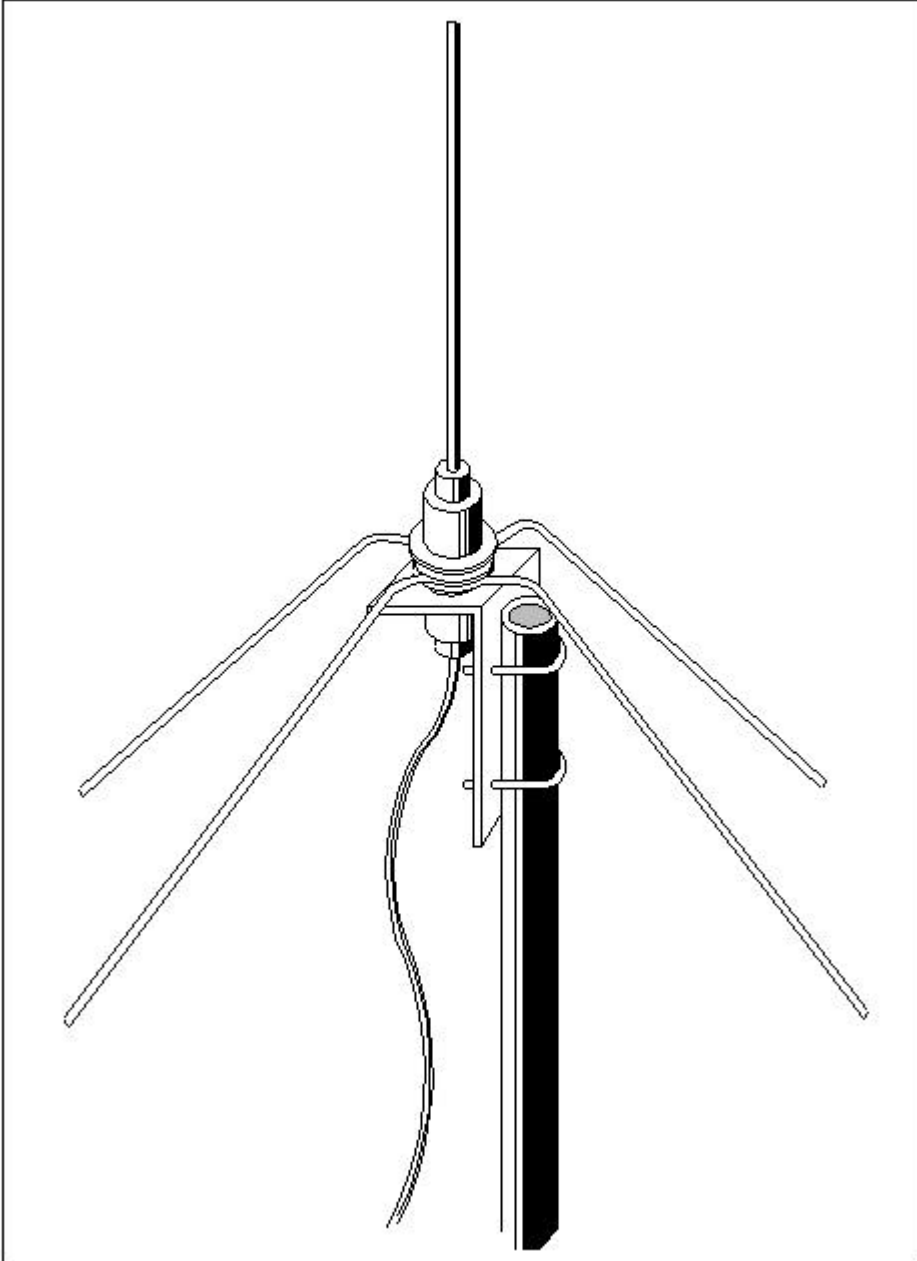

Figure 2.16 Mounting the groundplane antenna Model FQ-2.

Spread the radial elements around with equal spaces between them and tighten the PL-259 to fix the assembly firmly (see Figure 2.17).

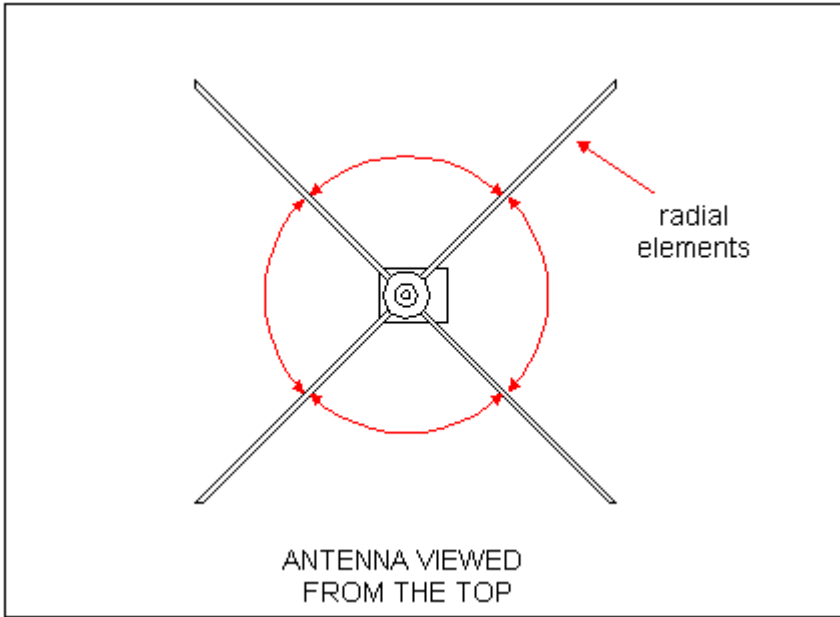

Figure 2.17 Spreading the radials.

3 GROUNDPLANE ANTENNA

Model FC-

2

The antenna is a vital link in the chain of radiocommunications and numerous designs have come off the drafting boards in a never ending search for improved performance. Experience shows that one major factor influencing the overall design of antennas is the particularity of the situation where it will be used. For example, the situation around fixed installations allows the antenna to be constructed with durable and heavy materials to make it mechanically strong. High power gain can also be easily attained by stacking a number of identical antenna. However, in mobile operation the situation drastically changes and using antennas designed primarily for fixed installations becomes impractical. Mobile

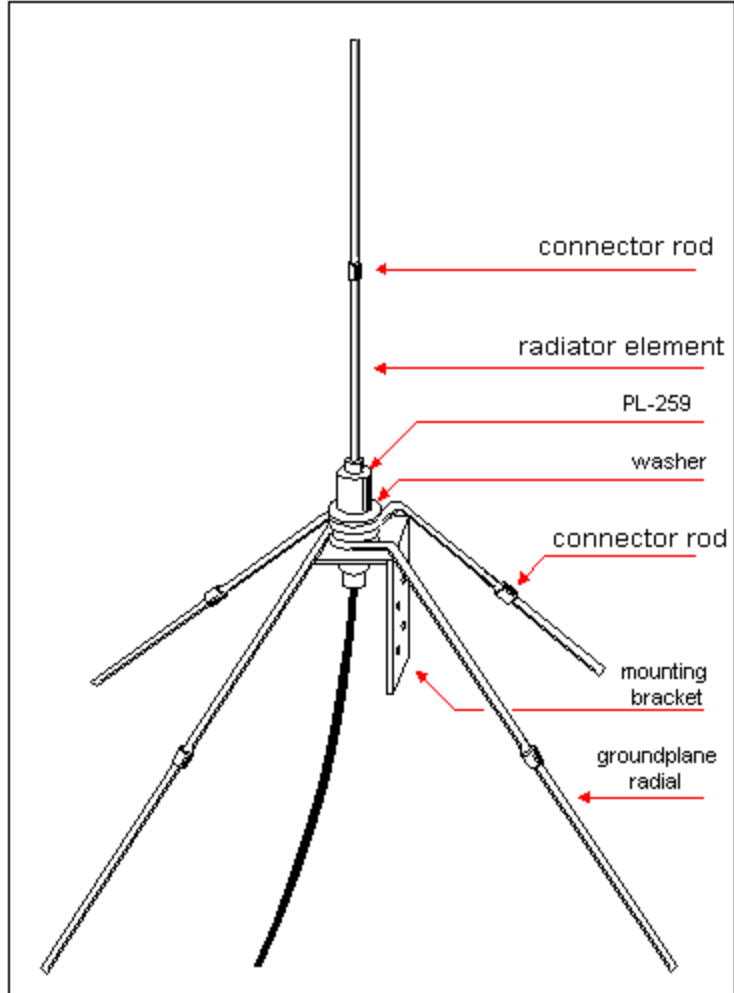

operation imposes limitations on the design of an antenna regarding its weight, size, ruggedness, easiness in assembly and disassembly, and power gain. The operator has to choose a type of antenna which is highly portable and at the same time functionally efficient in mobile operations.

The groundplane antenna described in this chapter is another development from the FQ-2 model. It is actually the same antenna just "compacted" further to make its total size smaller and more portable when disassembled. This antenna was designed by a mobile radio operator several months after constructing his first groundplane antenna similar to Model FQ-2. Perhaps being unhappy about the bronze rods protruding out of his small knapsack he cut each rod in half and devised an ingenious way of connecting the elements together during assembly. That is how the FC-2 antenna was evolved.

The electrical characteristics of this antenna is similar to those of Model FQ-2. It also retains the mechanical durability of the earlier full length version. Being more compact it has become very popular among mobile radio operators.

Materials needed

The materials needed for Model FC-2 are the same with those needed for Model FQ-2. Refer to the preceding chapter for the exact description of materials. The only difference between the two is the additional 3/16 inch diameter brass rod which is used to interconnect the detachable elements of the Model FC-2.

The compact detachable elements of the Model FC-2 permit it to be carried inside a pack or bag for mobile operations.

Construction

Fabricate a complete Model FQ-2 antenna following the construction methods described in the preceding chapter. After you have constructed the Model FQ-2 disassemble it and cut the radiator and each radial element into two equal lengths (see Figure 3.2).

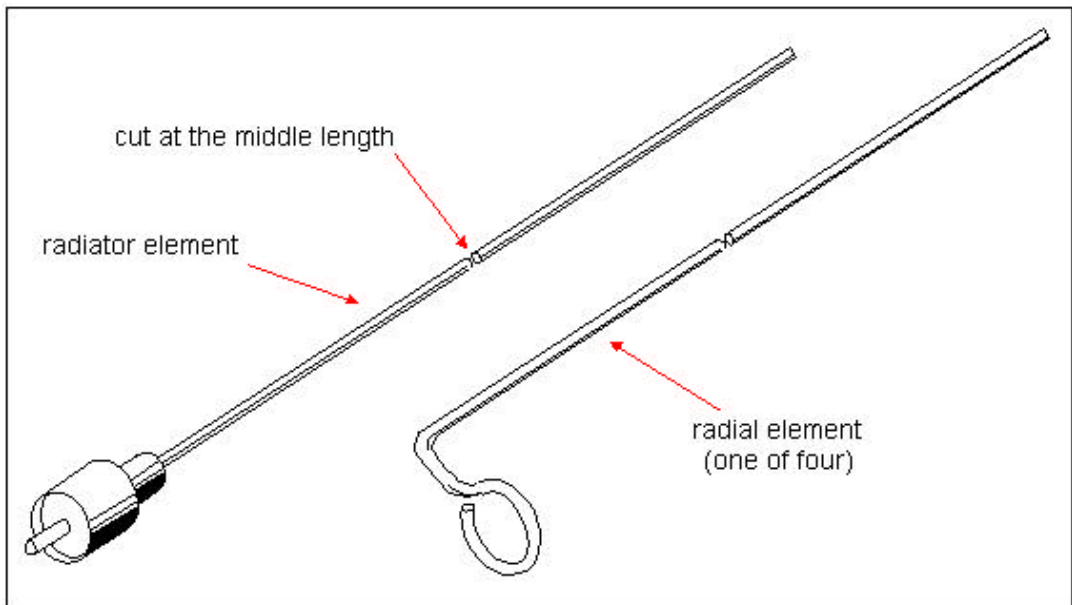

Figure 3.2 Cutting the elements into two equal lengths.

Next, take the 3/16" diameter brass rod and cut five 3/4 inch pieces from it. These short pieces of brass rod will be used to connect the two equal lengths of each element (see Figure 3.3).

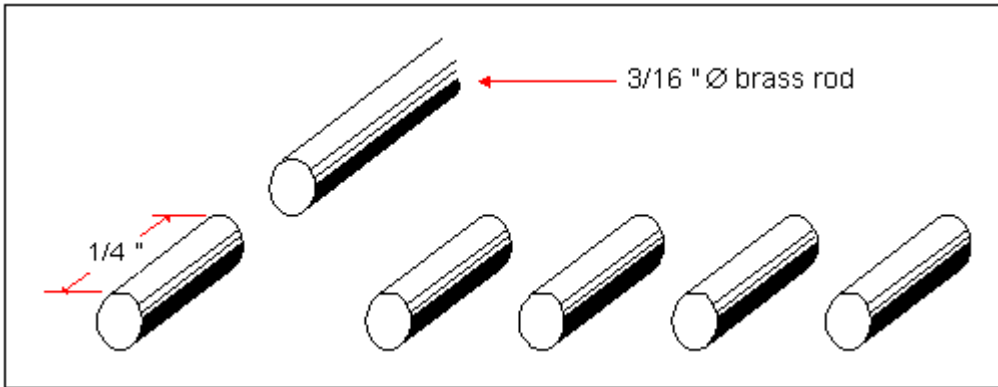

Figure 3.3 Preparing the connecting rods.

Drill a hole about 1/8 inch diameter at one end of each connector rod. The hole must be about half the length of the connector rod deep (see Figure 3.4).

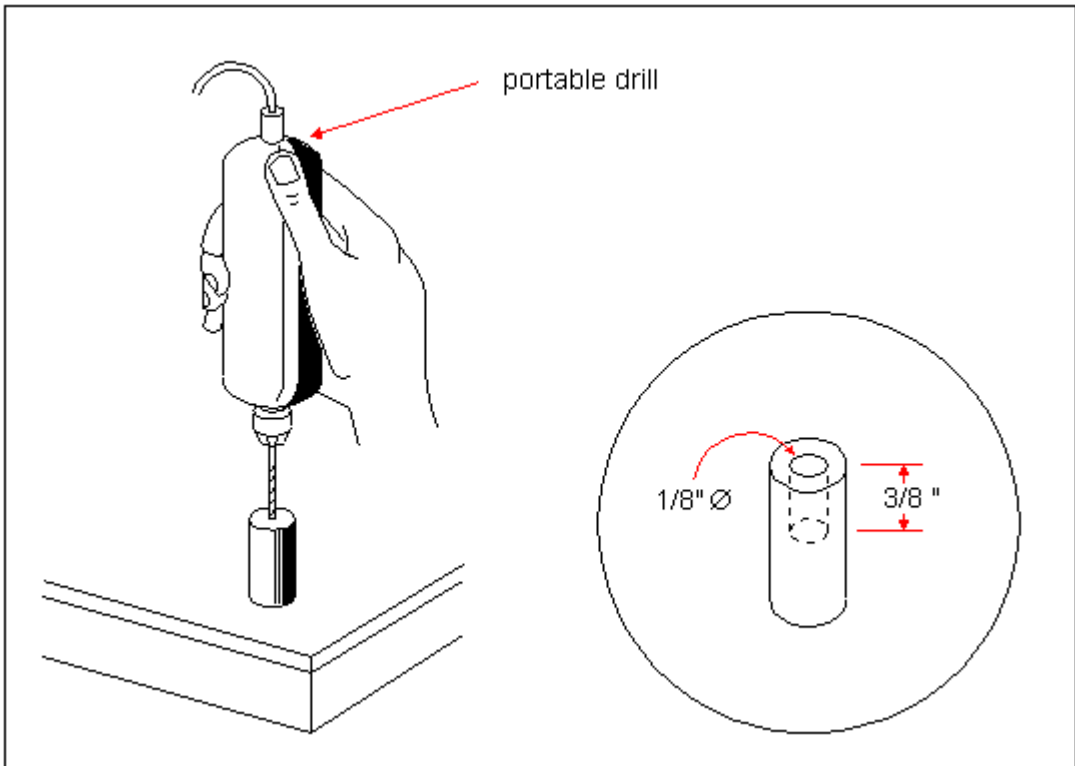

Figure 3.4 Drilling holes in the connector rods.

Next, drill another hole about 3/32 inch diameter at the other end of each connector rod - the same deepnes with the first hole (see Figure 3.5). Repeat the procedure for all five connector rods.

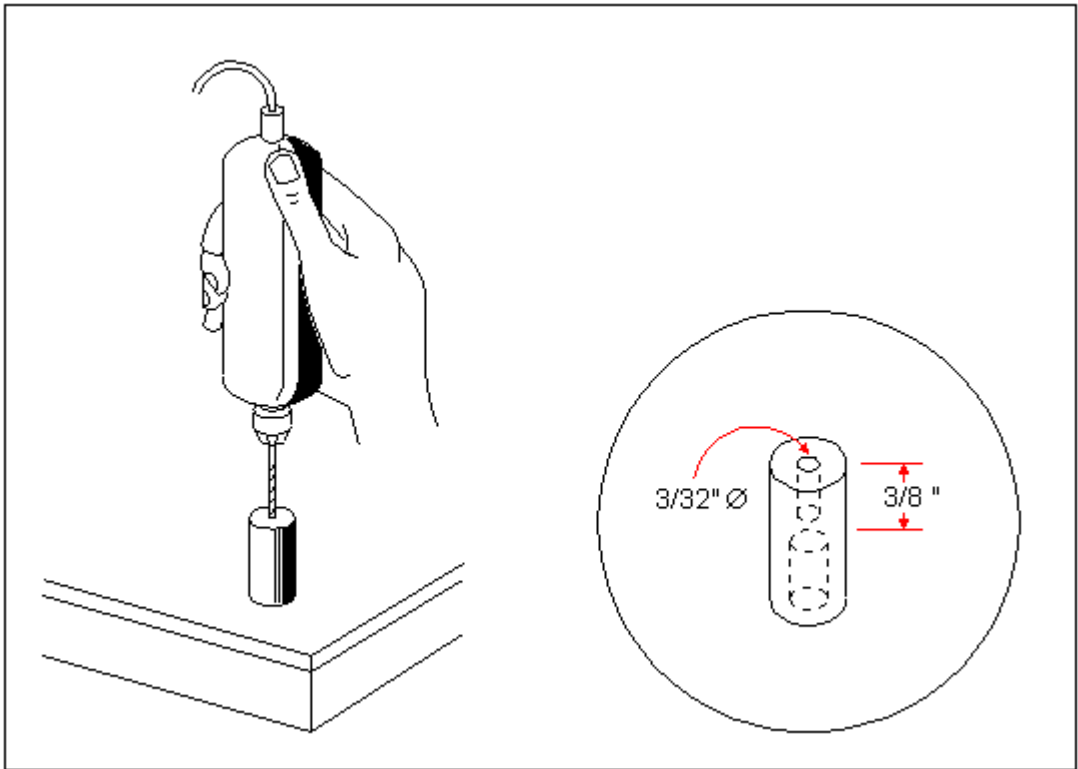

Figure 3.5 Drilling a 3/32" hole in the other end of the connector rods.

Next, secure the connector rod in a table vise and make a thread **inside the smaller hole** (the 3/32 inch hole to be sure) with a 1/8" gauge NF hand tap (see Figure 3.6). Repeat the same procedure for the remaining connector rods.

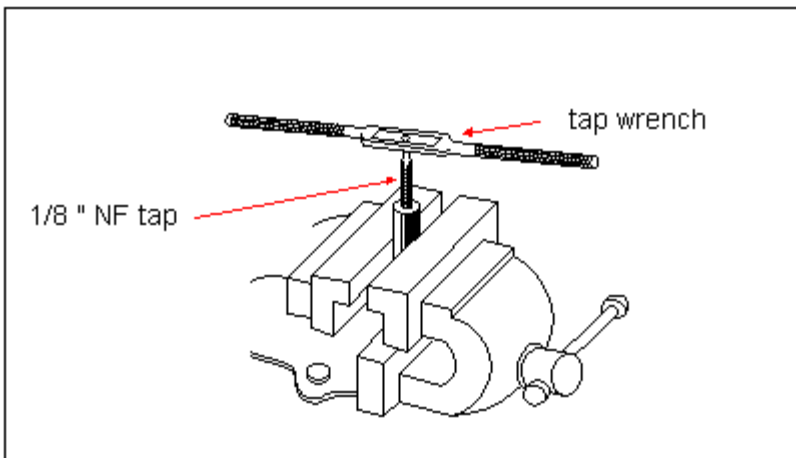

Figure 3.6 Making a thread in the smaller hole.

Insert the inner half rod of the radial element (the half part with the eyehook end) into the larger hole of the connector rod (1/8 " diameter hole unthreaded) and solder the two parts together. Do the same with the other radial elements (see Figure 3.7).

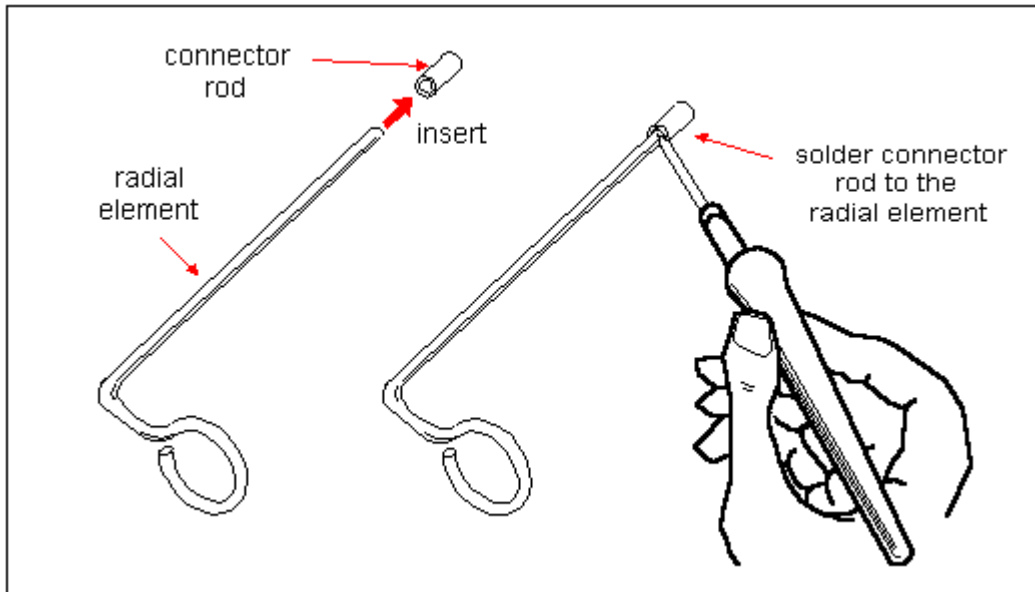

Figure 3.7 Coupling the connector rods to the radial elements.

Insert and solder the top half of the radiator element into the larger half of the remaining connector rod (see Figure 3.8). **NOTE: The purpose of this arrangement is to avoid the mistake of connecting the top half of the radiator to any of the radial elements.**

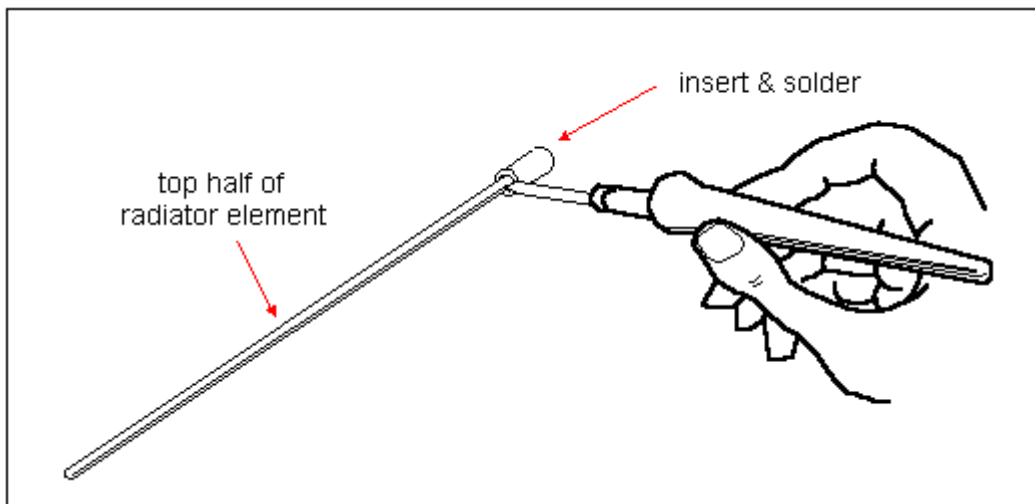

Figure 3.8 Coupling the top half of the radiator element to a connector rod.

Next step is to make a thread around one end of the outer half of the radial element. Use a manual threading die to make the thread. Secure the rod firmly in a table vise while threading. The thread must be at least 3/8 inch long. See Figure 3.9.

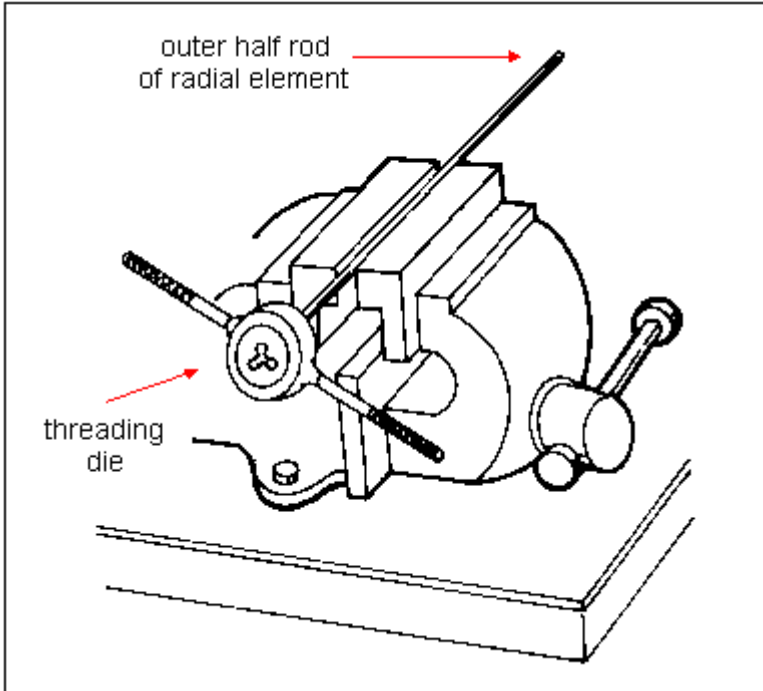

Figure 3.9 Making a thread at one end of the outer radial element.

After you have successfully made the threads, screw each outer half into its respective connector rod (see Figure 3.10).

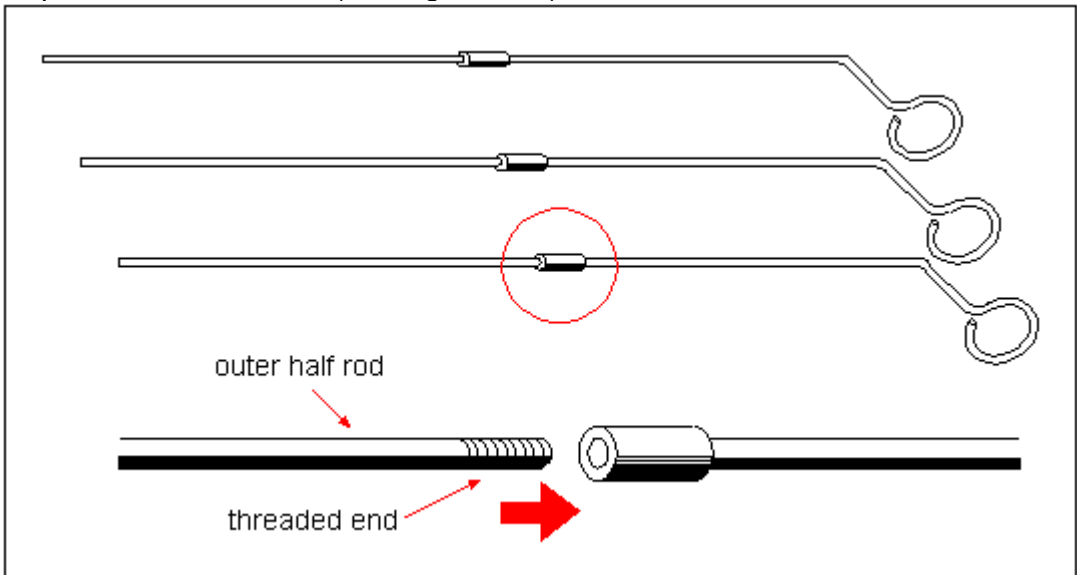

Figure 3.10 Assembling the radial elements.

Next, make a thread at the end of the lower half of the radiator element similar to what you have done to the radial elements (see Figure 3.11). Join the two halves of the radiator element together.

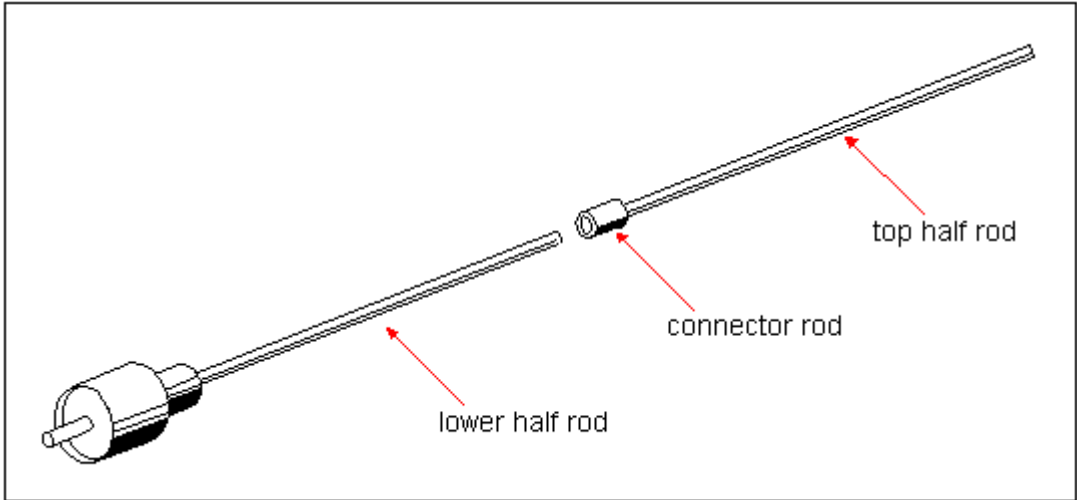

Figure 3.11 Assembling the radiator element together.

The final assembly of the Model FC-2 is similar to the Model FQ-2.

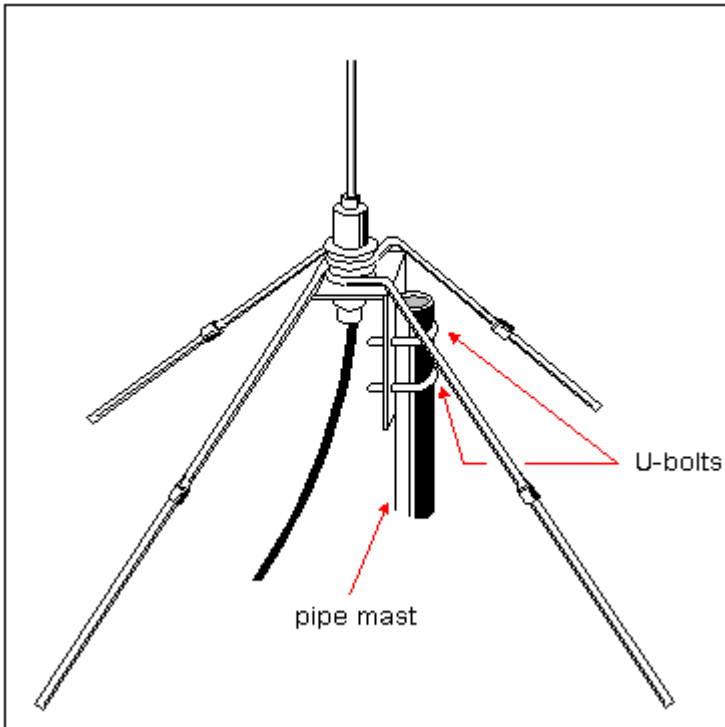

Figure 3.12 Final assembly and mounting of FC-2.

Mobile Installation

In mobile installations, the aluminum mounting bracket is not necessary and may be discarded and substituted with a 5/8" id* plain washer to hold the radial elements assembly. The antenna is then mounted by tying a rope at its base and hanging it under a tree or a makeshift post (see Figure 3.13a). An alternative method of hanging the FC-2 is to bend tip of the radiator element into a small hookform and a nylon rope is then tied to this hook to hang the antenna (See Figure 3.13b).

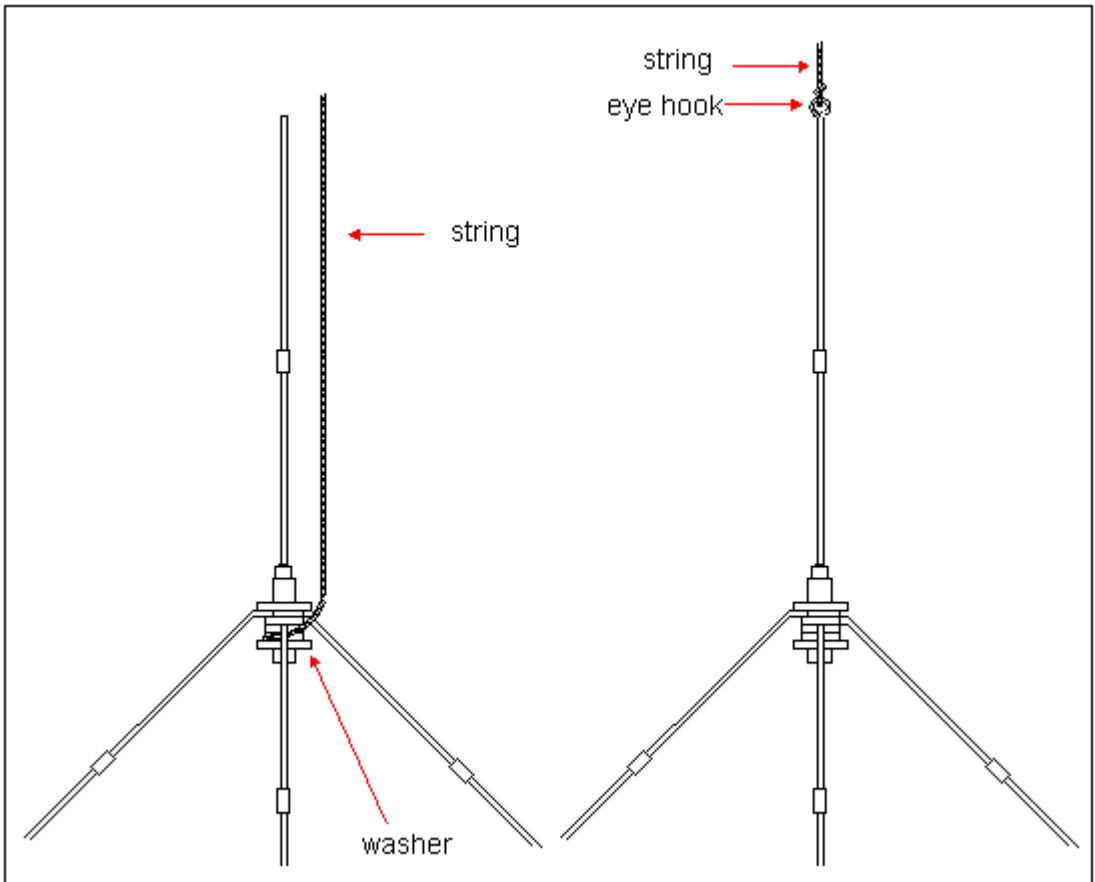

Figure 3.13 Mobile operation installation techniques.

4 J-FED HALFWAVE ANTENNA

Model JF-2

This antenna is specifically designed to satisfy the need for a simple but effective vertical antenna which does not require any grounding system. It is one version of a monopole antenna that carries its 'ground' along with it. The unit is comprised of a halfwave radiating element and a quarterwavelength matching section. The combination of these two elements provides the transformer action that matches the impedance. Although it is actually a quarterwave antenna, its radiation pattern and characteristics are very similar to those of a halfwave vertical antenna. It also exhibits a slight gain compared to a quarterwave groundplane antenna.

This antenna radiates its signal in an omni-directional pattern like most vertical antennas do. Its operational bandwidth is 140 - 150 MHz and exhibits an SWR response of less than 1.5:1 over the entire band.

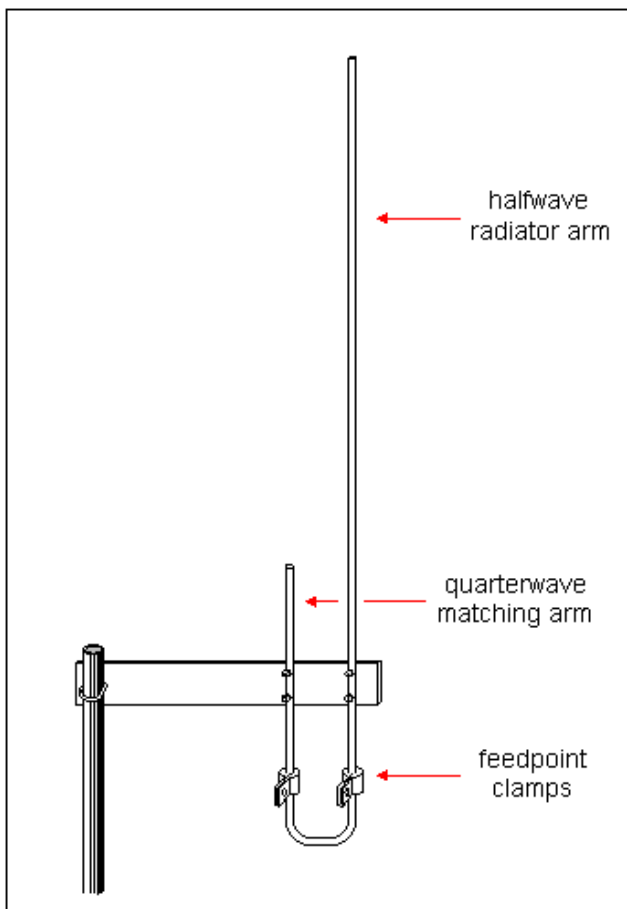

The unit described in this chapter is designed for fixed installation. If you intend to use it for mobile operation it would be better if you modify the design to adapt it to the rugged environment it will encounter. Aluminum tubes in general are thin and soft and will easily crack if handled roughly so you must substitute it with brass, bronze or copper tubing. These materials are more expensive but they are more durable. They are also resistant to corrosion.

The elements must be cut in two or three sections and some means must be provided to join the pieces of tubing together in assembly (similar to FC-2 technique). You must also devise a method of mounting the antenna in a much simpler fashion than the one described here. Hanging the antenna under a tree or post will do, but there might be some other way that you can think of. One word of caution though, never use any metallic material to mount the antenna. All points in the antenna element are electrically active so it must be insulated from ground.

Materials List		
Quantity	Specification/Description	Dimensions
1	Aluminum or Brass tube 3/8" od*	1" long
2	Aluminum strips - see text to make a strip out of a short length of aluminum tube	1/2" x 1-1/2"
1	Plastic plate 1/2" thick see text for details	3" x 12"
1	U-bolt with accompanying hex nuts and lockwashers	
4	Stove bolts - brass or GI with accompanying hex nuts and lockwashers	1/8" x 1"
2	Stove bolts - brass or GI	1/8" x 3/8"
2	Eye terminals - vinyl insulated	
4	Plain washers - 1/8" id**	
1	Hose clamp - enough to hold 1" diameter tube	
Miscellaneous: Epoxy glue		

* od- outside diameter ** id- inside diameter

Construction

Cut the tube to a length of 81 inches using a suitable tube cutter. Next, starting from one end measure about 55 inches and starting at this point bend the tube to a U-shape. The two 'arms' of the bent tube must be spaced 2-1/8" apart from each other (see Figure 4.2).

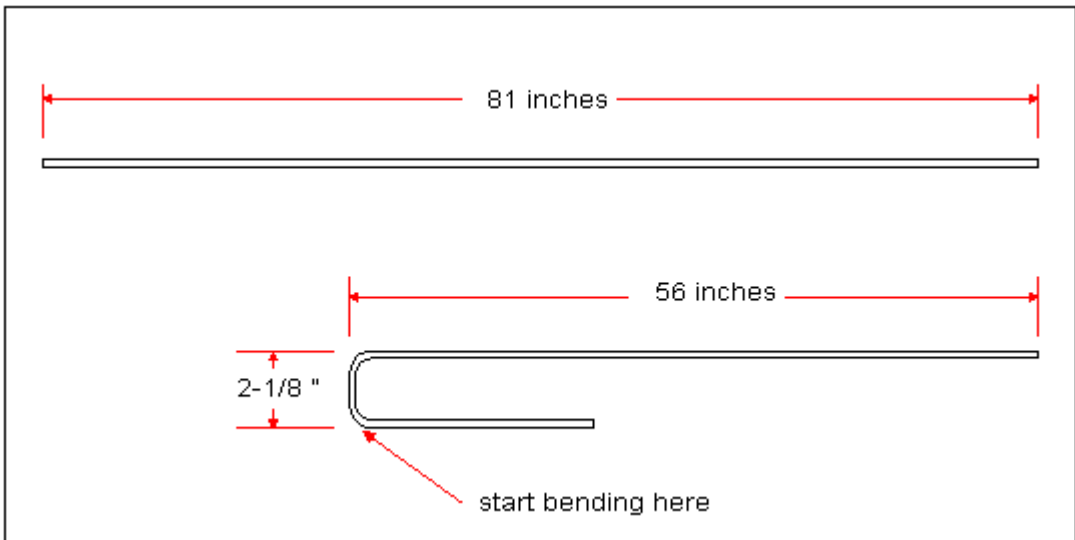

Figure 4.2 Bending one end of the tube.

Trim each arm of the tube to their proper lengths measuring from the extreme edge of the bend (see Figure 4.3). This method is employed to give an allowance for possible errors in bending the tube.

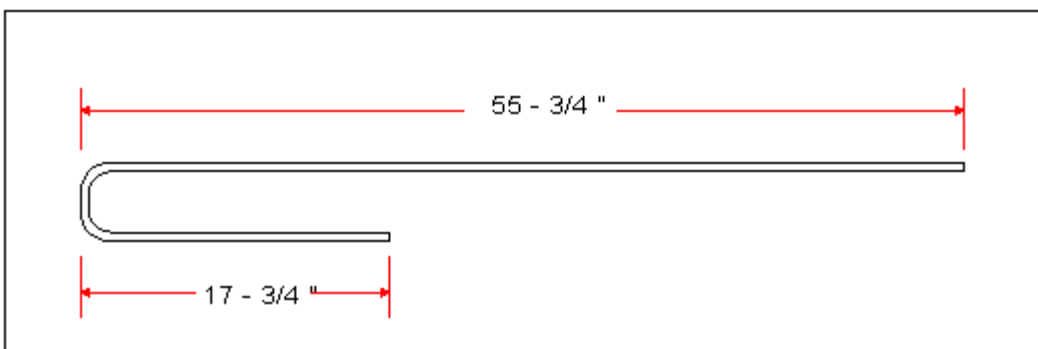

Figure 4.3 Trimming the tube to its exact length.

Drill four holes near the bend of the tube (see Figure 4.4). Each hole must be 1/8" in diameter.

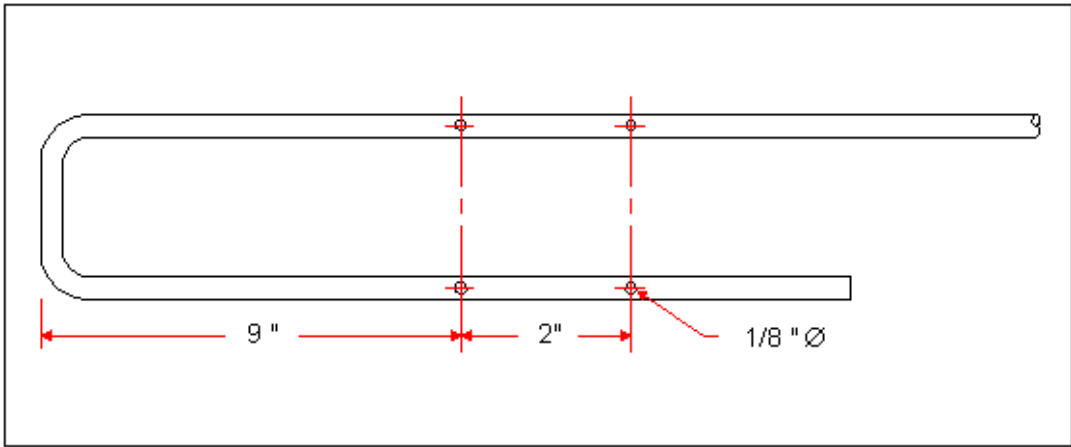

Figure 4.4 Drilling holes in the tube.

After drilling the holes, seal off both ends of the tube with an epoxy glue to avoid the entry of rainwater inside (see Figure 4.5). First, insert a substantial volume of cotton inside to act as a stopper for the epoxy. Then follow it up with epoxy glue levelling it to the edge of the tube. Let the epoxy set and dry before proceeding.

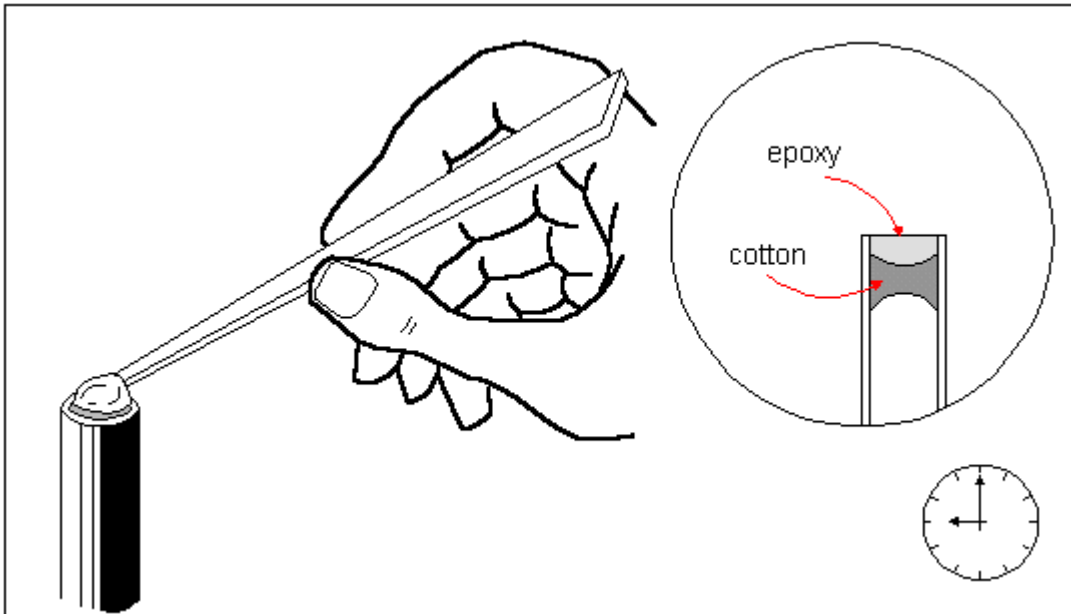

Figure 4.5 Sealing off the open ends of the tube with epoxy glue.

While you are waiting for the epoxy glue to dry, prepare the plastic plate for the antenna mount. Drill holes in the plastic plate following the dimensions shown in Figure 4.6. The larger hole ($3/16$ " diameter) is intended for the U-bolts so their dimensions must coincide with the actual U-bolt used.

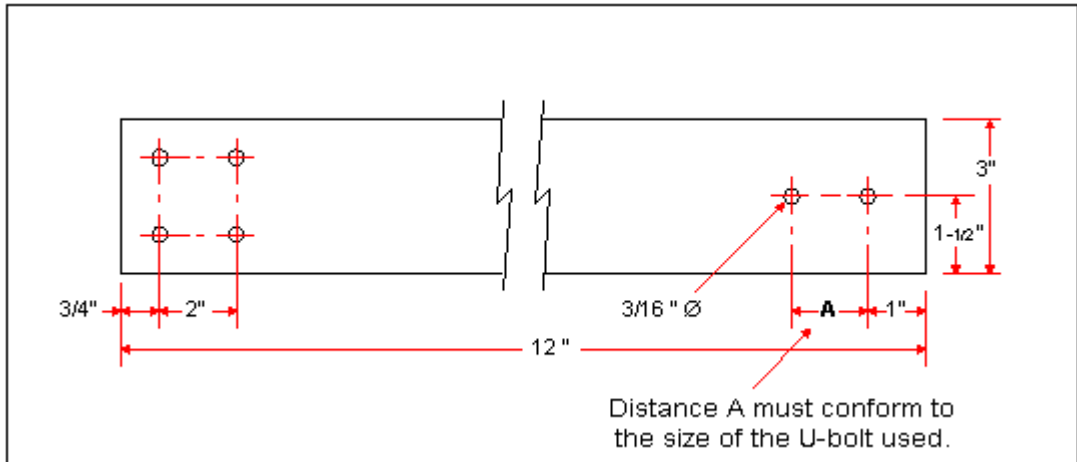

Figure 4.6 Preparing the plastic mounting plate.

Fabricate a metal strip out of a short length of aluminum tube (about 5 inches long) by pressing it in a table vise until the tube is flattened (see Figure 4.7).

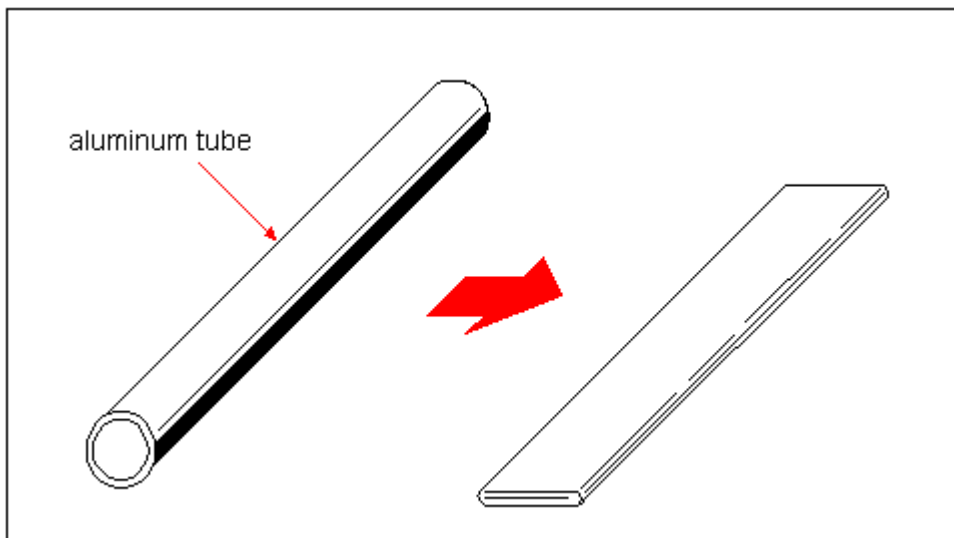

Figure 4.7 Fabricating a metal strip out of a short aluminum tube.

Out of this strip cut two short pieces (about 1-1/2" long). Bend the two strips to a form of a clamp to fit tightly around the antenna tubing (see Figure 4.8). These clamps serve as the feedpoint terminals of the antenna.

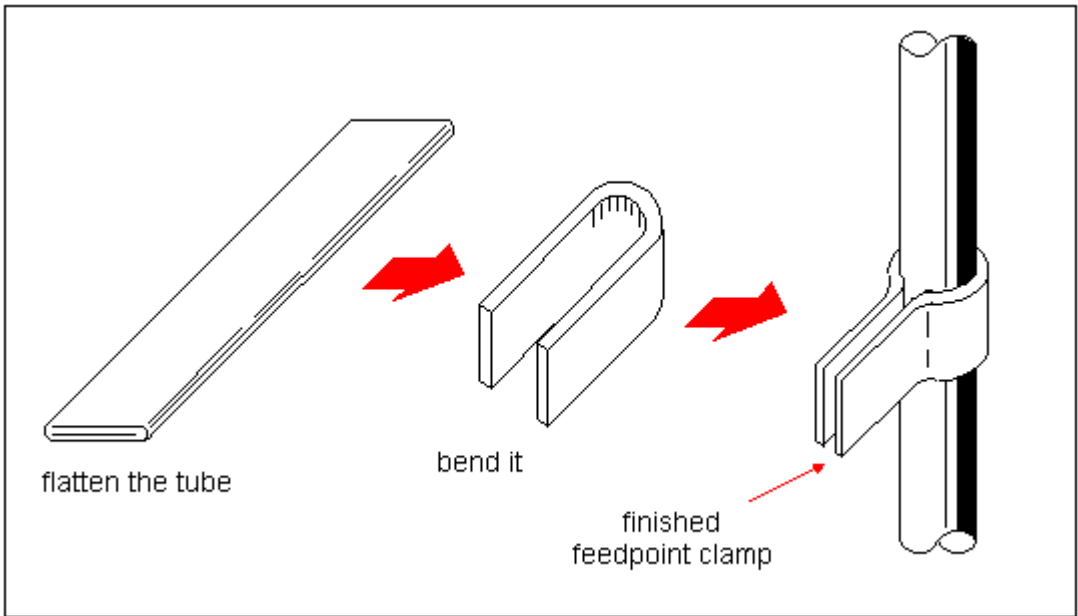

Figure 4.8 Fabricating the clamps.

Next, drill a hole about 1/8" diameter through the flattened end of each feedpoint clamp (see Figure 4.9).

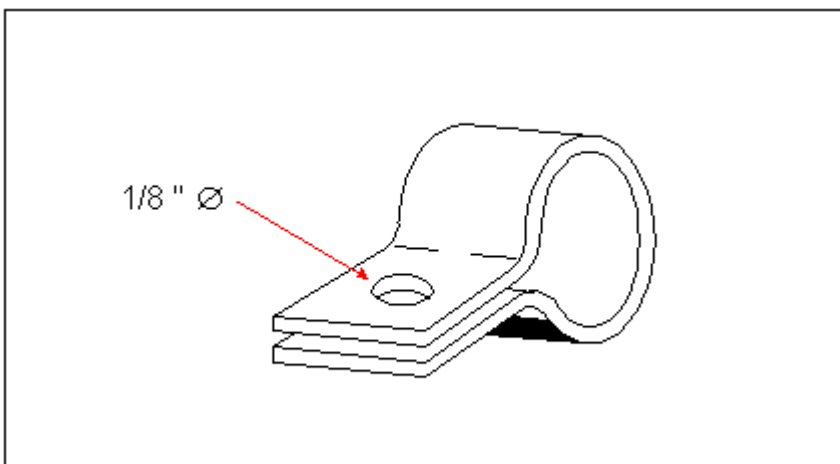

Figure 4.9 A feedpoint clamp with a drilled 1/8" diameter hole.

Assembly

First, attach the J-shaped tube to the plastic mounting plate with 1/8" x 3/4" stove bolts made of corrosion proof materials such as brass or stainless steel. Do not forget to include the necessary lockwashers in the attachment (see Figure 4.10). Be careful in tightening the nut because the tube is hollow inside and it might collapse damaging the tube. Apply torque to the nuts just enough to hold the tube rigidly.

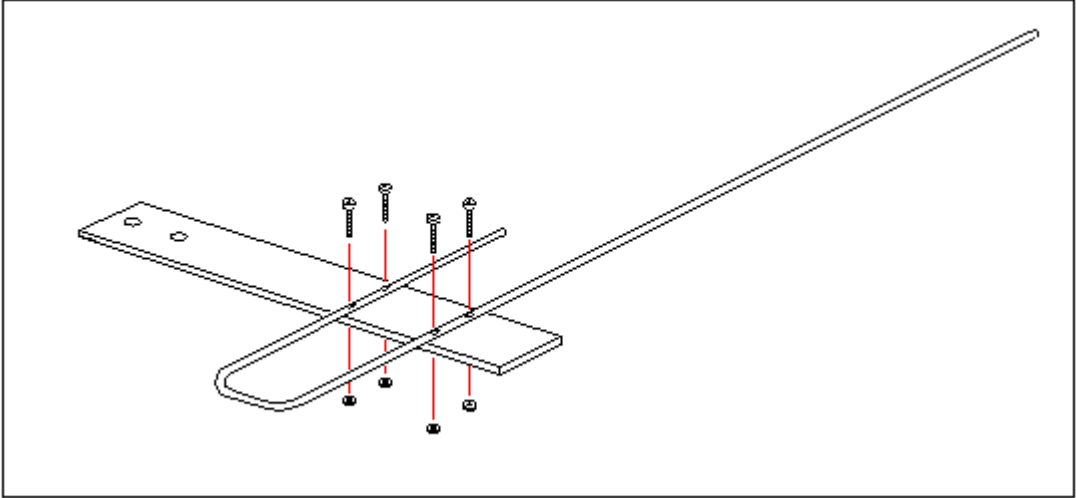

Figure 4.10 Securing the J-shaped tube to the mounting plate.

Attach the feedpoint clamps into both arms of the the tube. Attach one clamp on the shorter arm of the tube and attach the other clamp on the longer arm (see Figure 4.11).

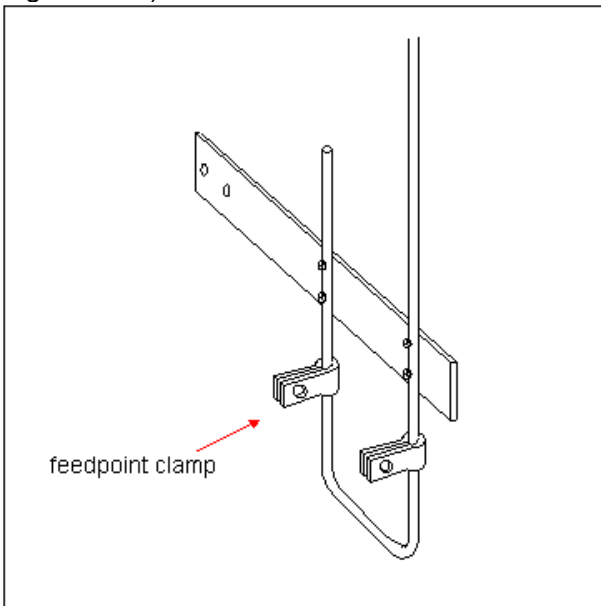

Figure 4.11 Feedpoint clamps attached to the antenna.

Attach a plain washer and an eye terminal into a stove bolt (1/8" x 3/16") then insert the bolt into the hole in the feedpoint clamp sandwiching the eye terminal inbetween (see Figure 4.12). Place a lockwasher and a hex nut at the other end of the bolt then tighten the clamp lightly. Repeat the same procedure for the other clamp.

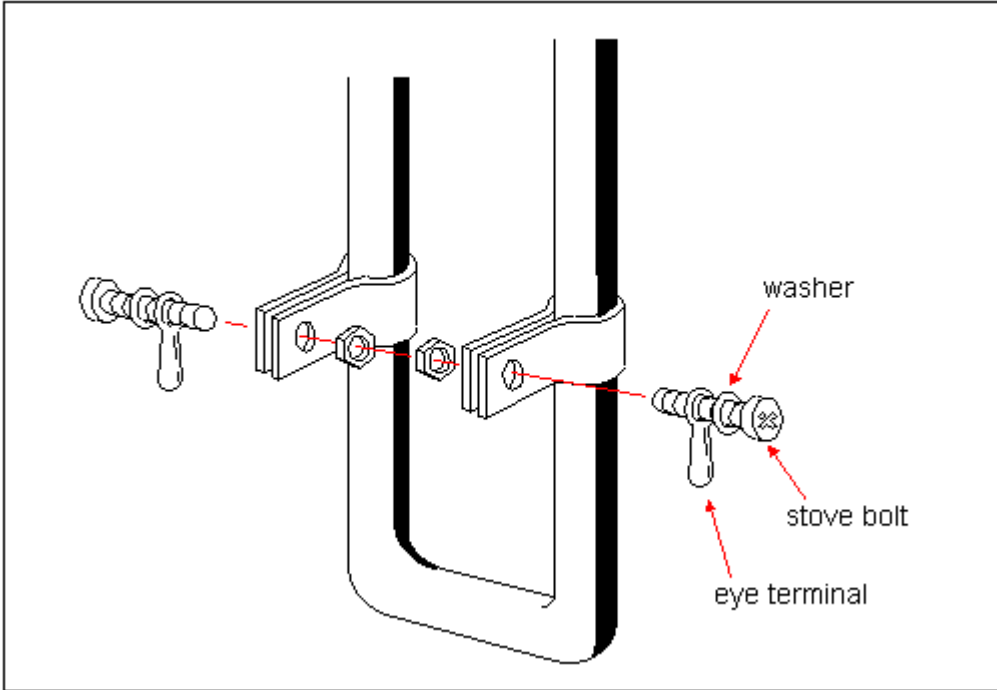

Figure 4.12 Assembling the feedpoint terminals.

Next step is to connect the coaxial cable to the feedpoint terminals. Prepare one end of the coaxial cable by separating the braid/shield from the inner conductor (see Figure 4.13).

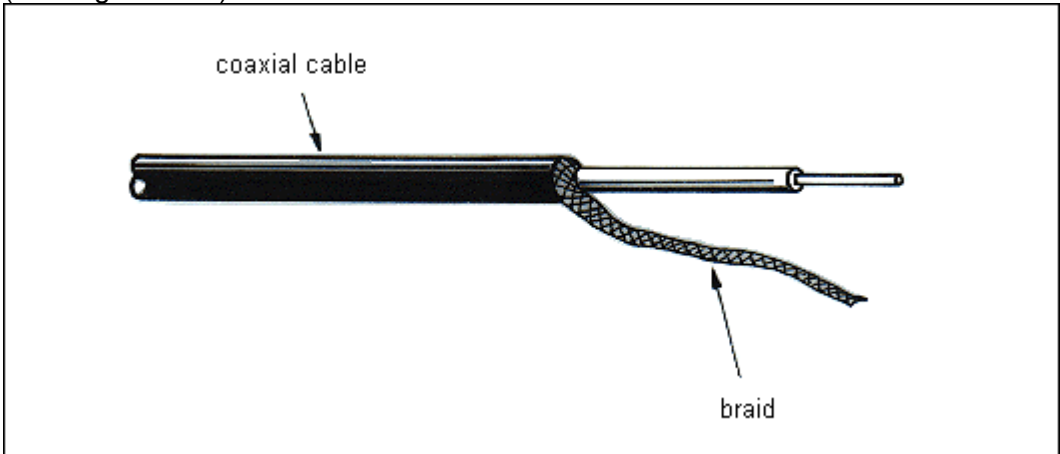

Figure 4.13 Making a pig tail.

Insert and solder the two conductors (braid and inner conductor) to the eye terminals attached in the feedpoint clamps. The braid must be connected to the shorter arm of the tube and the inner conductor must be connected to the longer arm (see Figure 4.14).

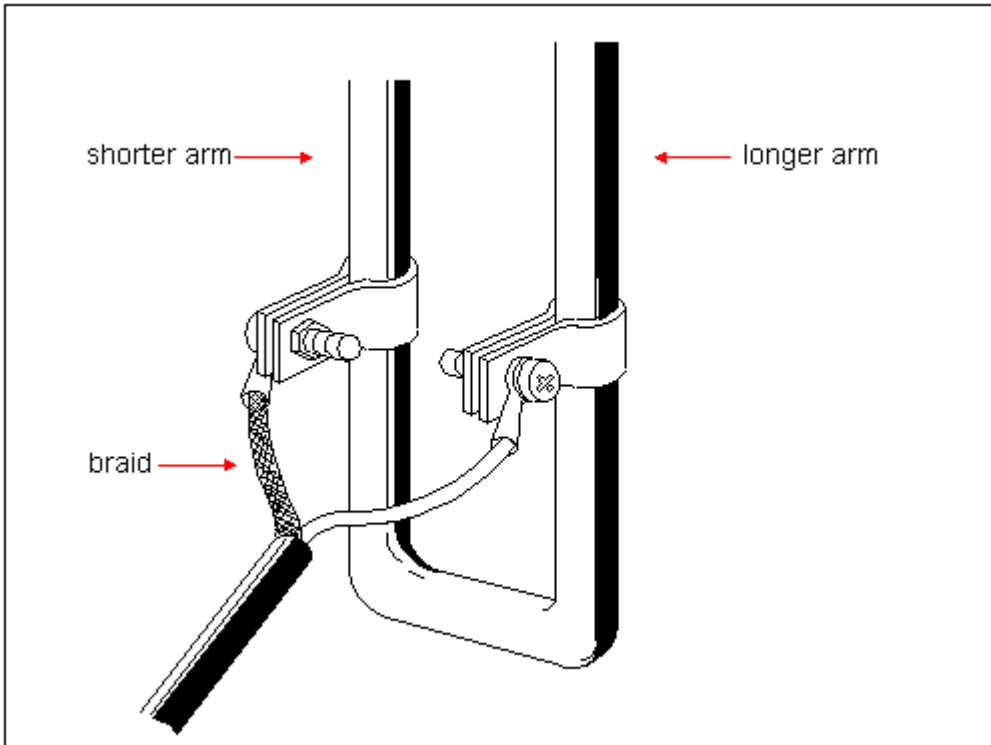

Figure 4.14 Connecting the coaxial cable to the feedpoint clamps.

Mount the antenna to the mast you intend to use. It is best to tune the antenna to resonance right at the mast where it will be installed permanently. Connect the coax cable to an SWR meter. The coaxial cable must be furnished with the right connectors for the particular type of SWR meter you use. Connect a transceiver to the input connector of the SWR meter (usually marked 'transmitter'). Set the transceiver to 145.00 MHz and key the PTT to transmit. Note the SWR reading on the meter. While the transceiver is on standby, move both feedpoint clamps higher or lower than the initial setting until you get a low SWR response over the entire frequency range (140.00 MHz to 150.00 MHz) specifically). Move the clamps about 1/4" at a time (see Figure 4.15).



IMPORTANT:

Do not move the clamps while the rig is transmitting and do not touch any part of the antenna when reading the SWR response. The position of the clamps must be moved always at the same level at the same time.

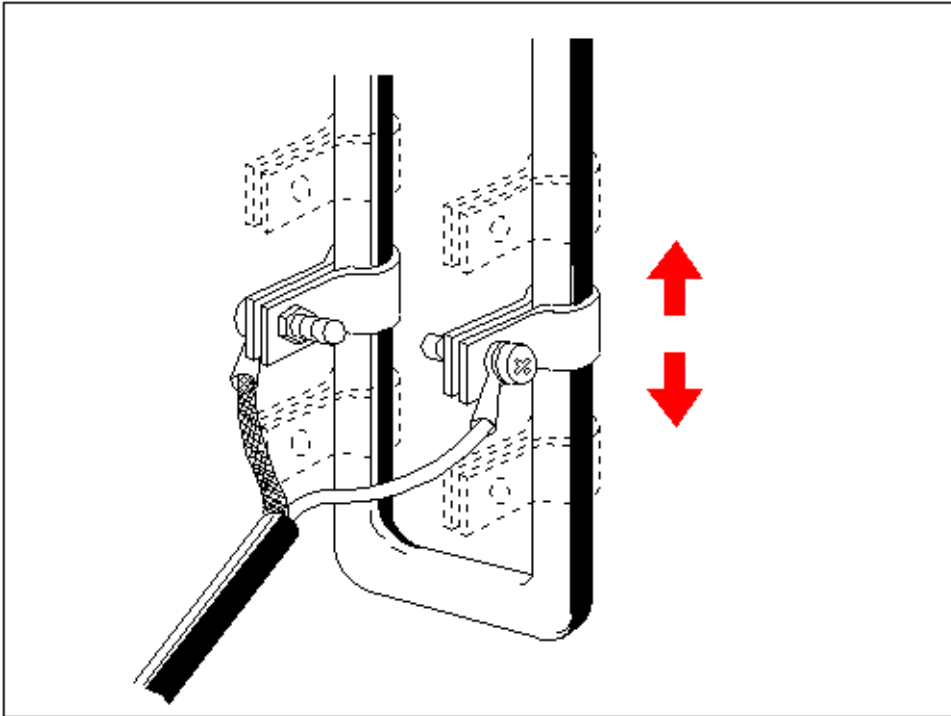

Figure 4.15 Adjusting the position of the clamps to tune the antenna.

After you have tuned the antenna to resonance, tighten the nuts holding the feedpoint clamps permanently and fix the coaxial cable to the mounting plate with plastic clamps (see Figure 4.16).

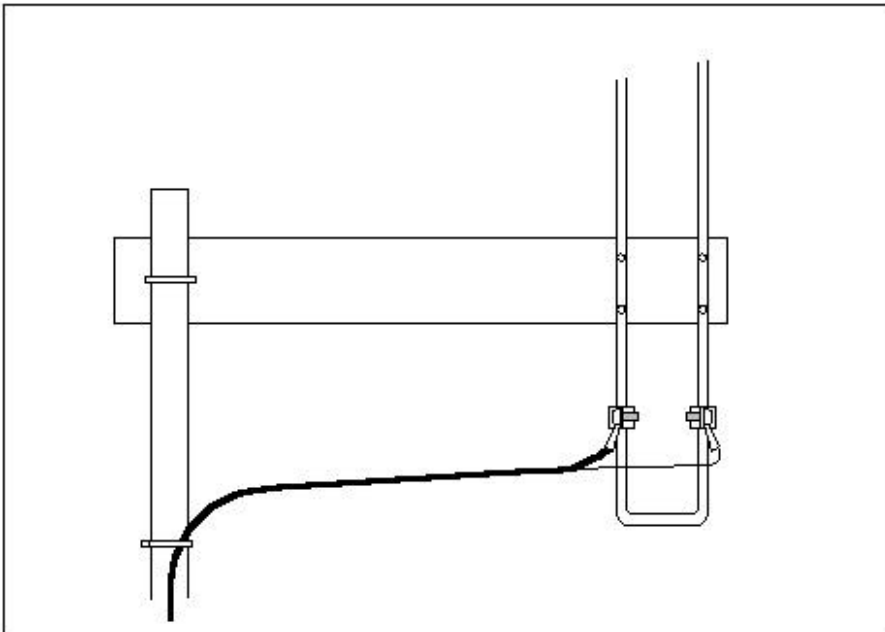

Figure 4.16 Final mounting of the J-fed antenna.

5 COAXIAL DIPOLE

Model CD-2

The coaxial dipole described here has the advantage of having lower resistance to wind compared to the groundplane designs. It has also a narrow form which some radio operators find beautiful. The following illustrations in Figure 5.1 show how the coaxial dipole was evolved from a basic dipole antenna.

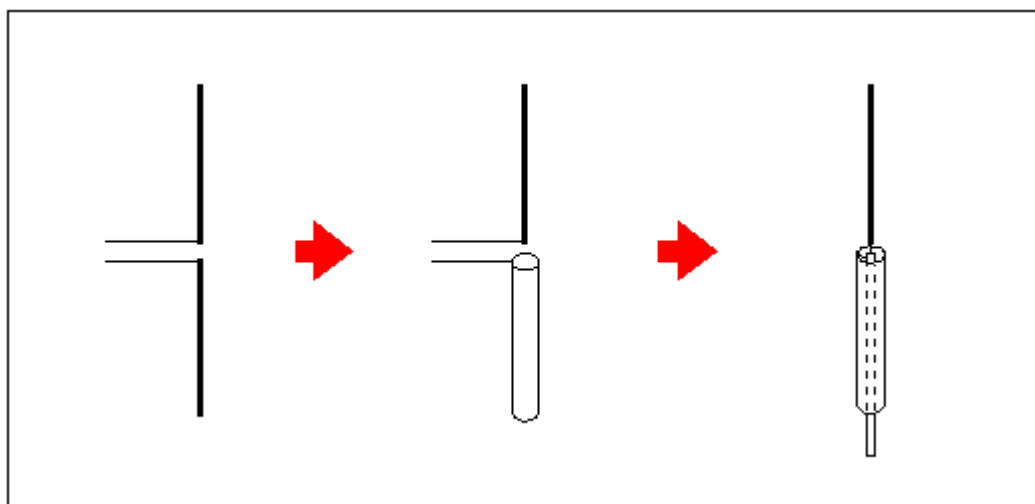

Figure 5.1 Evolution of the coaxial dipole from a basic dipole antenna.

As you can see in the illustration, one of the elements is enlarged to form a tube. The coaxial transmission cable is then inserted through this tube, with the inner conductor of the coaxial cable connected to the radiating element and the shield connected to the tube. The tube functions as a groundplane.

The CD-2 coaxial dipole has an operational bandwidth of 140-150 MHz. It exhibits an SWR response of less than 1.5:1 over the entire band. It has a power gain of 1 dB (unity gain) compared to a standard dipole reference. The RF signal radiates from the antenna in an omni-directional pattern. Likewise, it receives signal equally well from all directions. This unit is designed to be installed primarily in base stations but it could be used for mobile applications too. The radiating element must be detached when transporting the antenna.

SCALED DOWN APPEARANCE

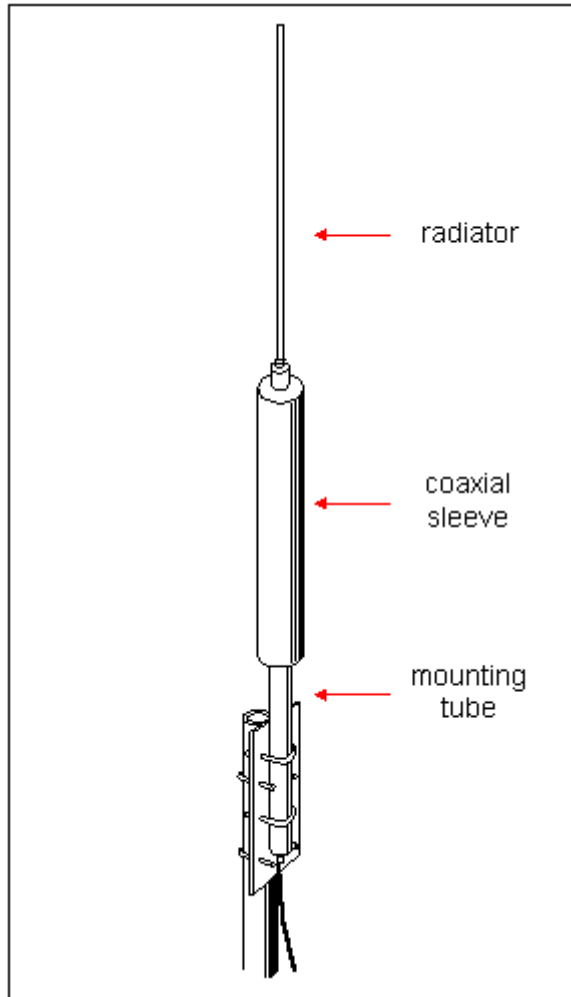

Figure 5.2

Materials List

Quantity	Specification/Description	Dimensions
1	Aluminum tube	3" x 18"
1	Aluminum tube	1" x 36"
1	PL-259 VHF male connector	
2	SO-239 VHF female connector	
1	Brass rod 1/8" od* - the brass rod for acetylene welding is recommended	
2	Aluminum bushing - see main text for exact dimensions	
4	U-bolts - with accompanying hex nuts and lockwashers	
1	Aluminum Plate or GI	3" x 6"
9	Self tapping metal screws	1/8" x 1/2"
1	Short length of coaxial cable RG-58/U	37" long

*od- outside diameter

Construction

First prepare the two aluminum tubes of different diameters. Cut the tubes to their proper lengths as shown in Figure 5.3

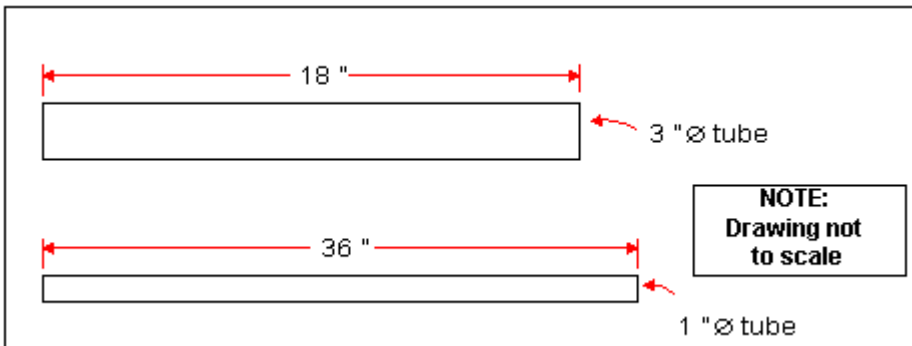

Figure 5.3 Cutting the tubes to their proper lengths.

Next, drill three holes (1/8" diameter) at **both ends** of the longer tube. The holes must be equally spaced from each other (see Figure 5.4).

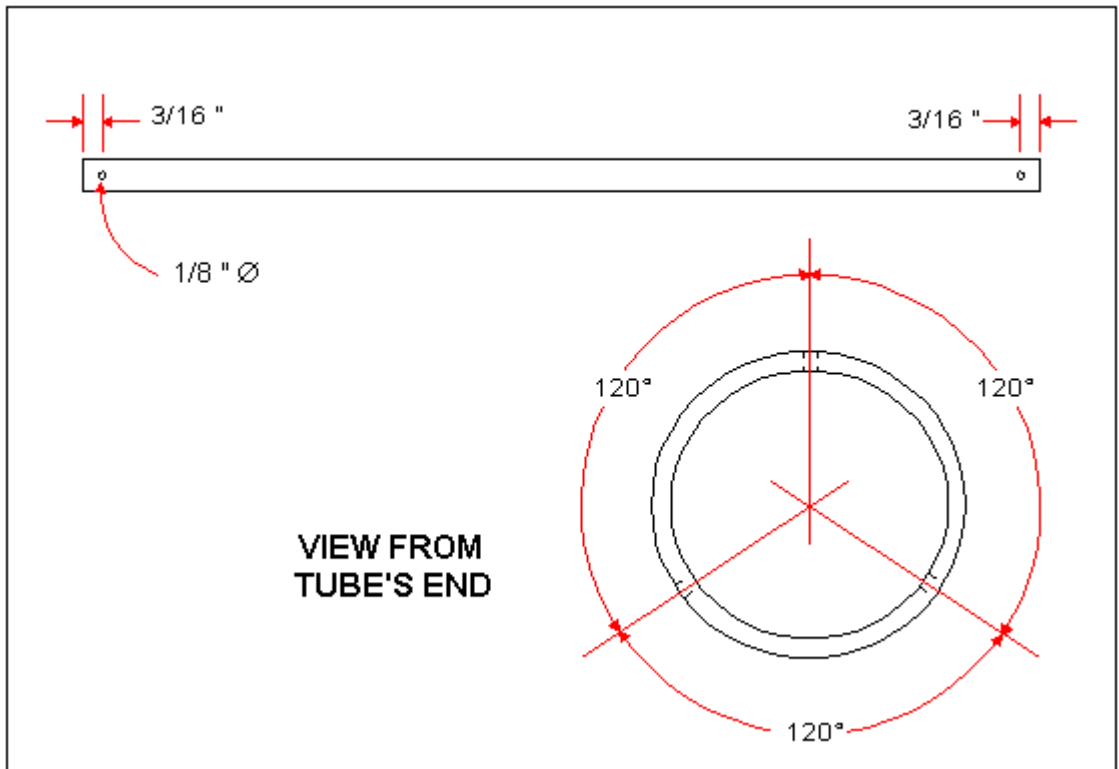

Figure 5.4 Drilling three holes at both ends of the long tube.

Drill three holes (1/8" diameter) at **one end** of the shorter tube. The holes must be 1/4" away from the edge and equally spaced from each other (Figure 5.5).

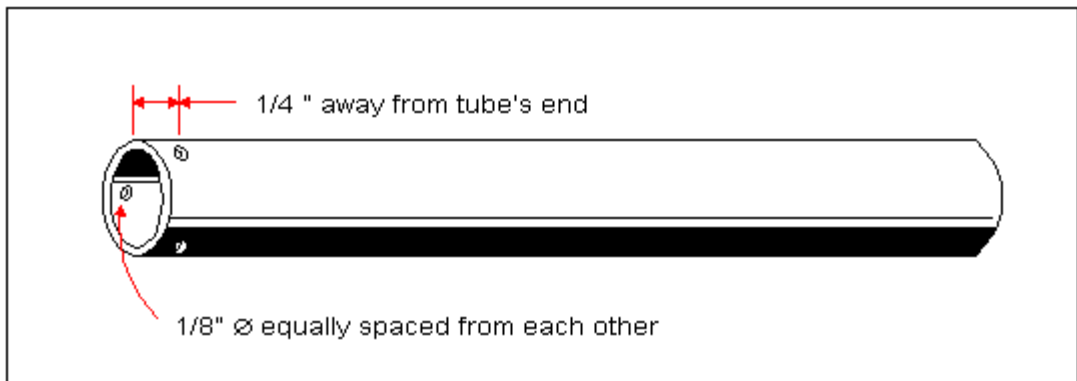

Figure 5.5 Drilling a hole at one end of the short tube.

Machine the smaller bushing from a thick aluminum slab or rod to its proper size. Follow the dimensions in Figure 5.6.

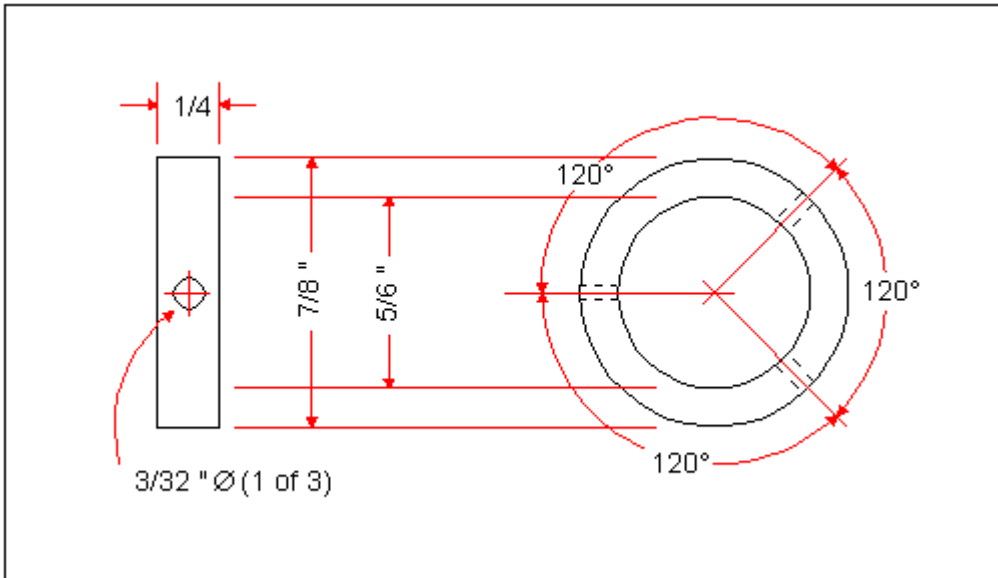

Figure 5.6 Smaller bushing dimensions.

Next, machine the larger bushing from similar material. Follow the dimensions shown in Figure 5.7.

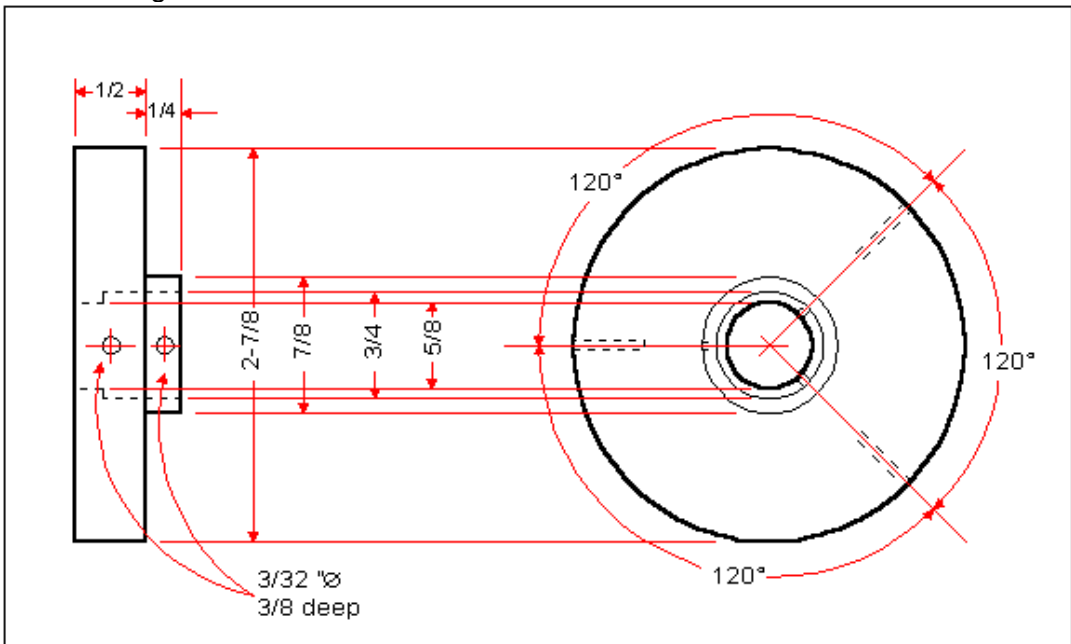

Figure 5.7 Dimensions of the larger bushing.

File away a small portion at one end of the brass rod reducing it to smaller diameter enough to fit inside the center pin of PL-259 connector. Solder the brass rod into the center pin of the PL-259 connector (see Figure 5.8).

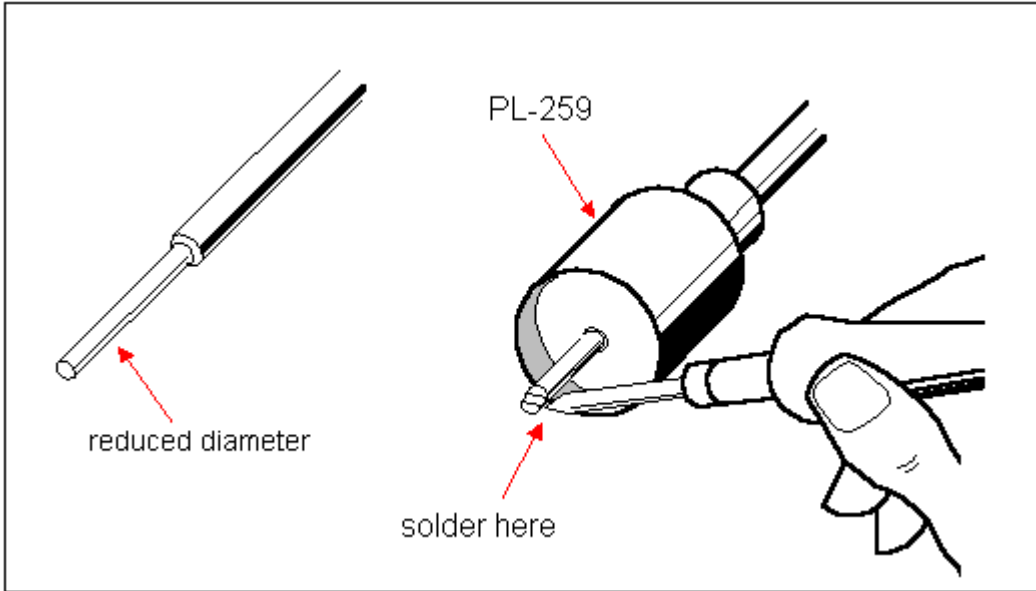

Figure 5.8 Soldering the radiator element to the PL-259.

Cut a small length of coaxial cable (about 2 inches) and remove its inner conductor and braid/shield. You need only the vinyl outer jacket. Insert it into the brass rod all the way inside the PL-259 connector. Cut away any protruding vinyl portion. The jacket serves as an insulator between the brass rod and the body of PL-259 (see Figure 5.9).

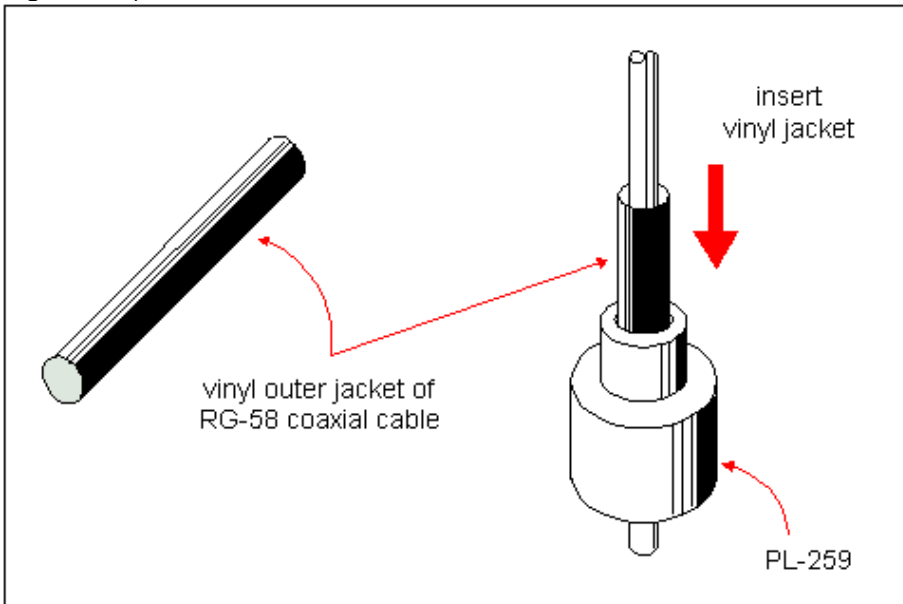

Figure 5.9 Inserting the insulating jacket into the PL-259.

Mix equal amount of epoxy glue and place it over and around the protruding part of the vinyl jacket (see Figure 5.10). The epoxy serves as a sealant to avoid the seepage of rainwater inside the PL-259 connector. Let the epoxy set and dry.

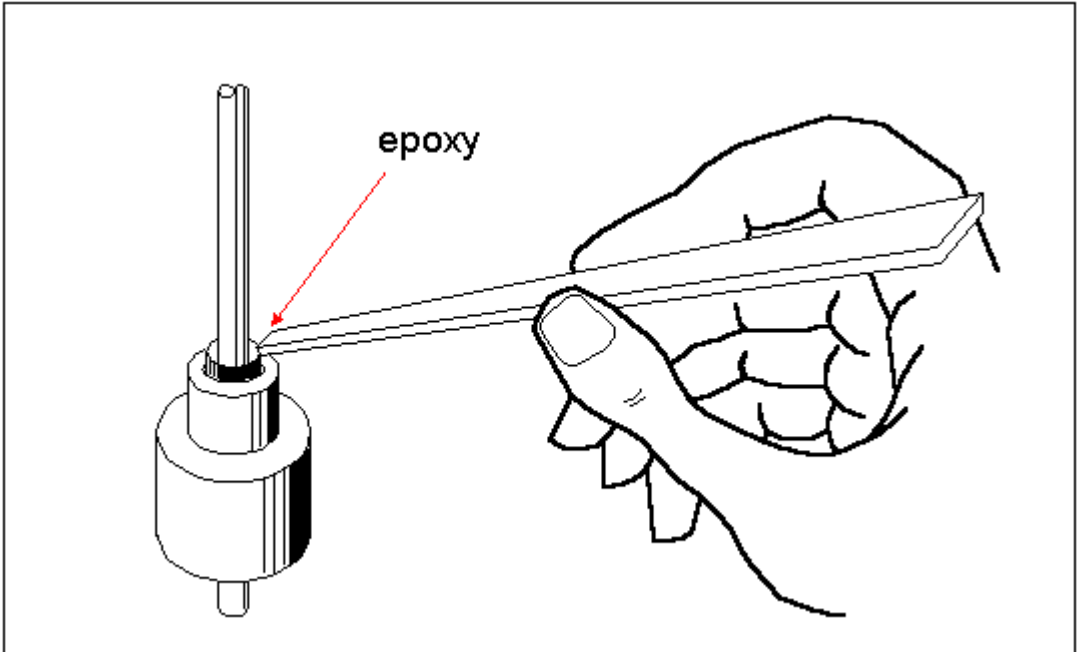

Figure 5.10 Sealing the PL-259 with epoxy glue.

Assembly

First attach the two SO-239 connectors into the two aluminum bushings as shown in Figure 5.11. Don't forget to include its grounding ring or solder lug.

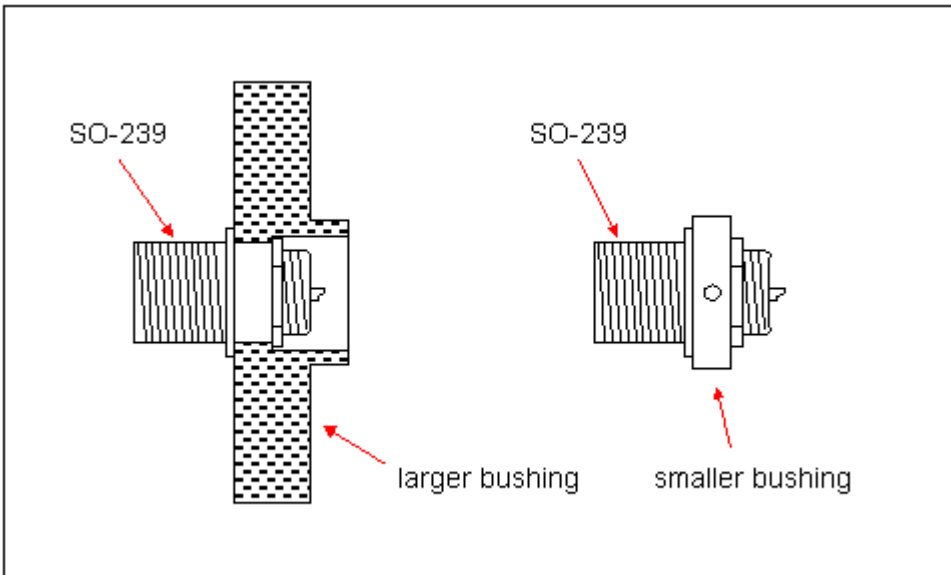

Figure 5.11 Mounting the SO-239 into the larger bushing.

Cut a 36 inches long coaxial cable (RG-58/U) and solder its conductors at one end to the SO-239 connector attached to the larger bushing (see Figure 5.12).

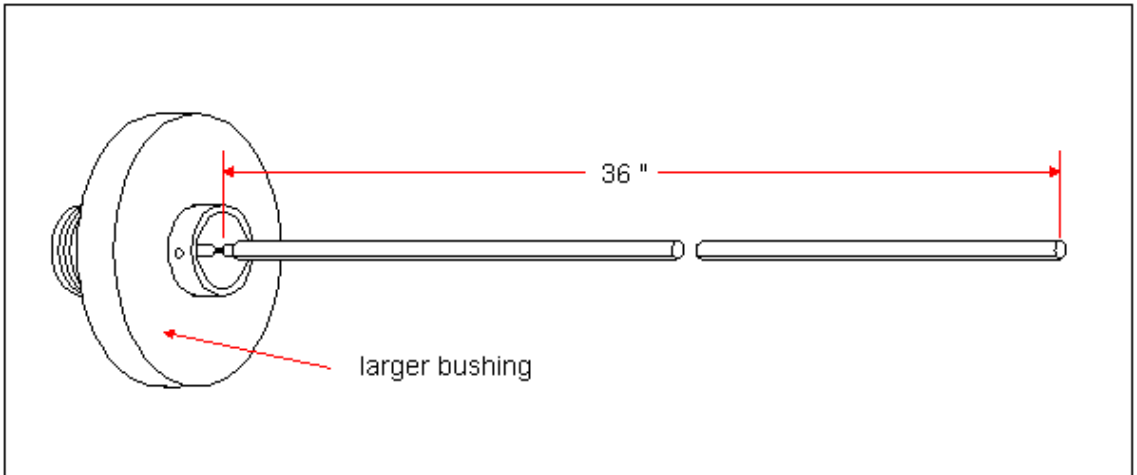

Figure 5.12 Soldering the coaxial cable to the SO-239.

Lay the coaxial cable and the longer tube side by side as they would be when they are finally assembled together. Trim the free end of the coaxial cable at the point $3/8$ " away from the end of the longer tube (see Figure 5.13).

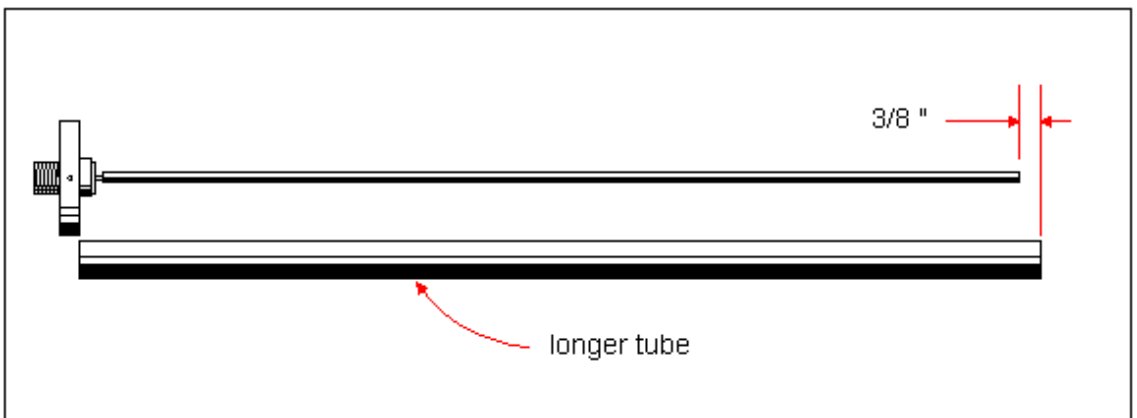

Figure 5.13 Trimming the coaxial cable to the proper length.

Solder the free end of the coax cable into the remaining SO-239 connector attached to the smaller bushing (see Figure 5.14).

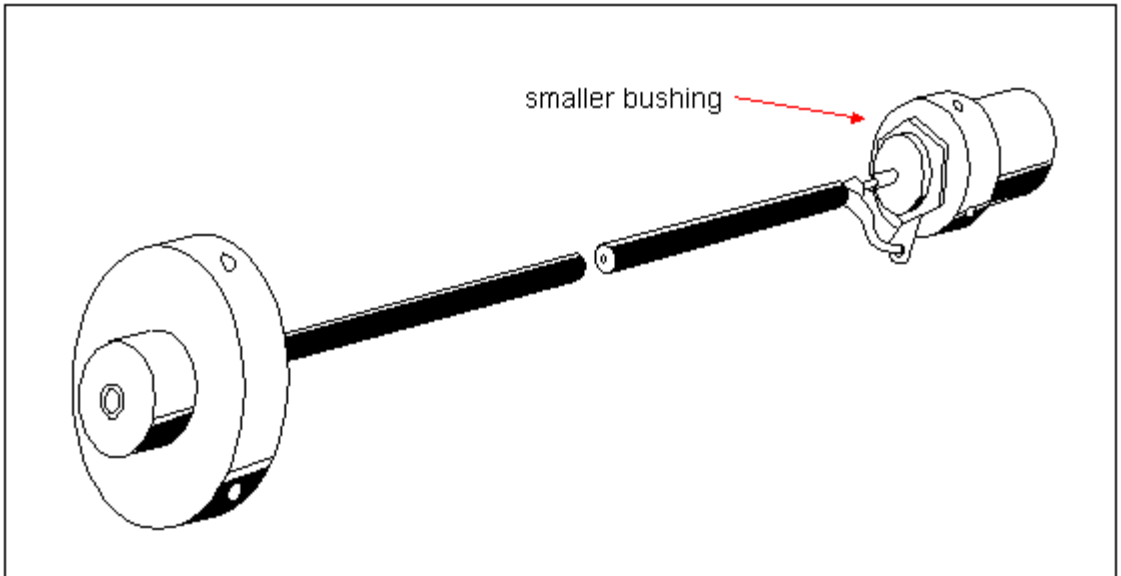

Figure 5.14 Soldering the other end of coaxial cable to the other SO-239.

Insert the smaller bushing, coaxial cable and the large bushing all the way inside the longer tube until the holes in the two bushings are aligned to the holes in the tube itself. If in your first try you did not manage to align the holes then maybe a slight retrimming of the coax cable is needed or the SO-239 connector must be repositioned or resoldered. After a few trials you should have done it right (see Figure 5.15).

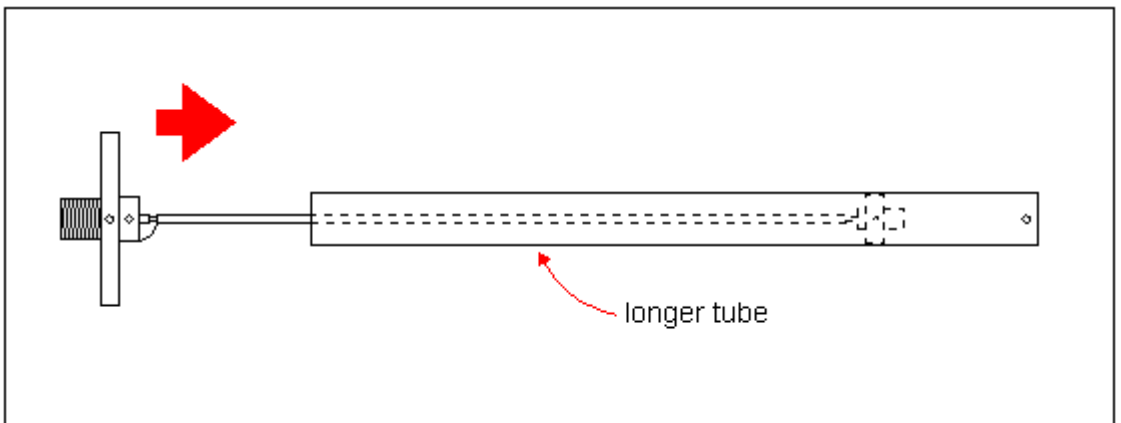

Figure 5.15 Inserting the feeder coaxial cable into the long tube.

Secure the two bushings permanently into the tube using self-tapping metal screws (see Figure 5.16).

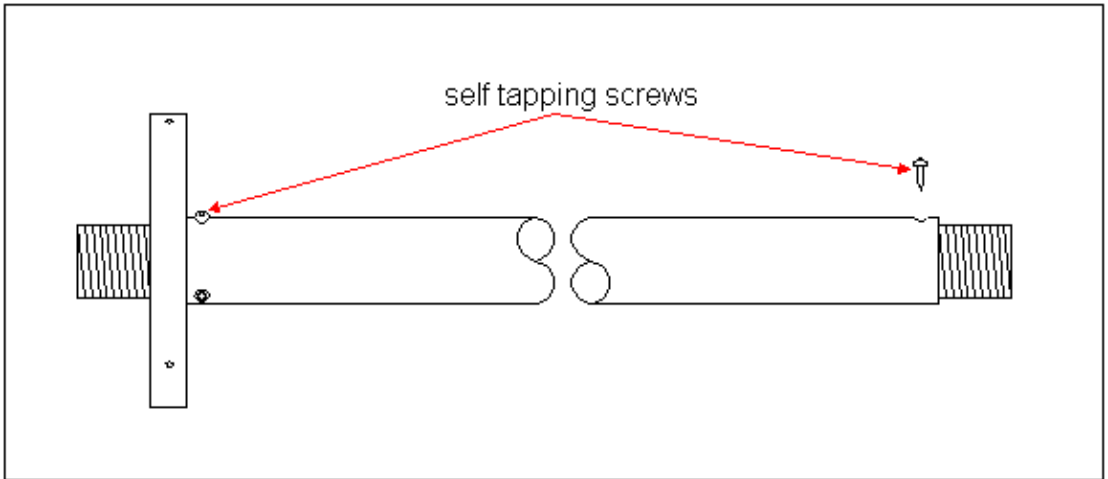

Figure 5.16 Securing the bushings and the tube together.

Insert the longer tube and the large bushing inside the shorter tube (see Figure 5.17). Align the holes in the large bushing to the holes in the shorter tube and place self-tapping screws through the holes to fix the bushing firmly inside the short tube.

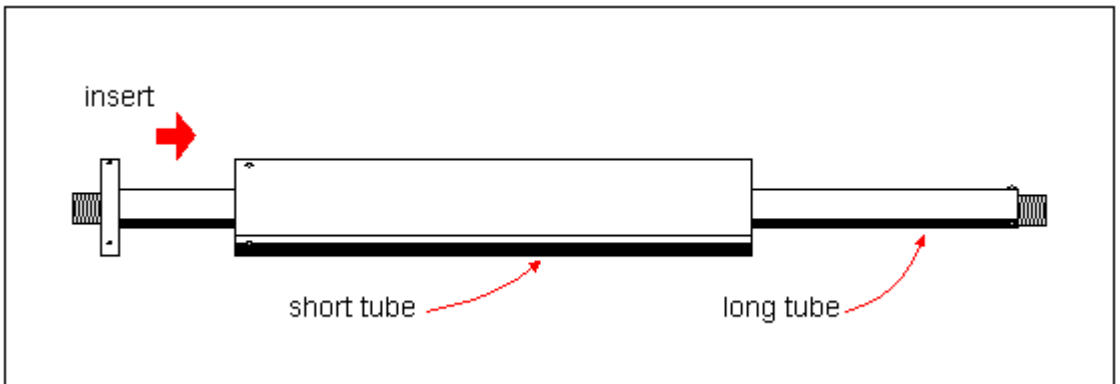

Figure 5.17 Assembling the two tubes together.

Attach the radiator element to the SO-239 connector in the upper larger bushing (see Figure 5.18).

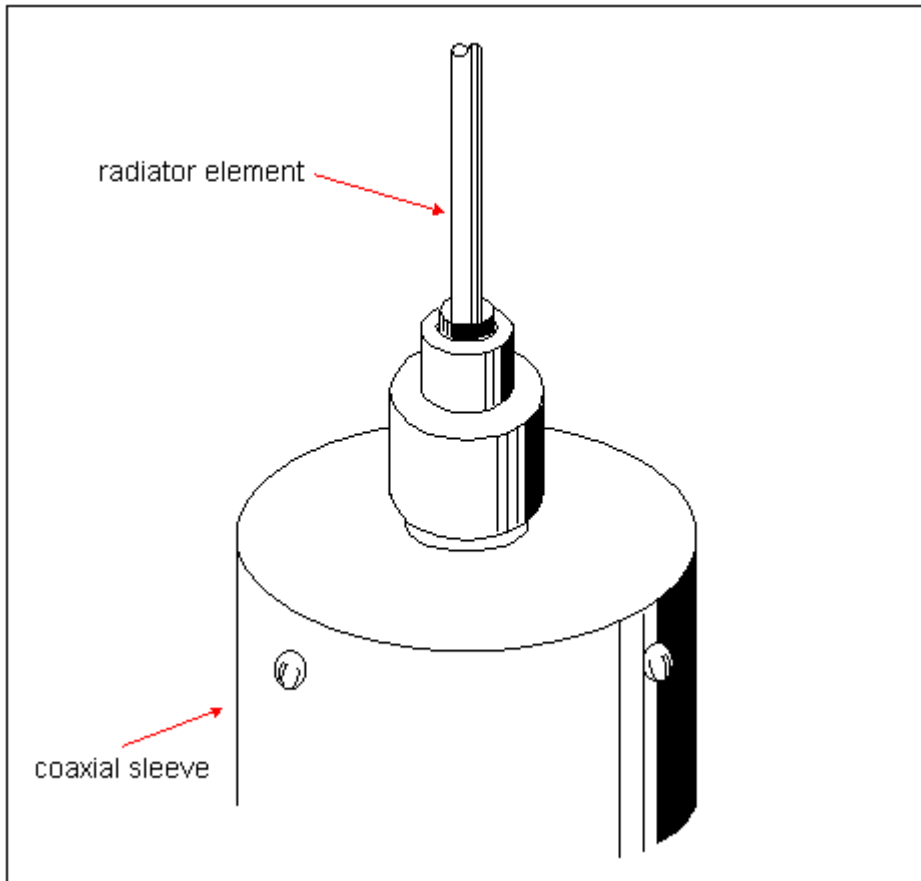

Figure 5.18 Installing the radiator element into the antenna base.

Installation of Model CD-2

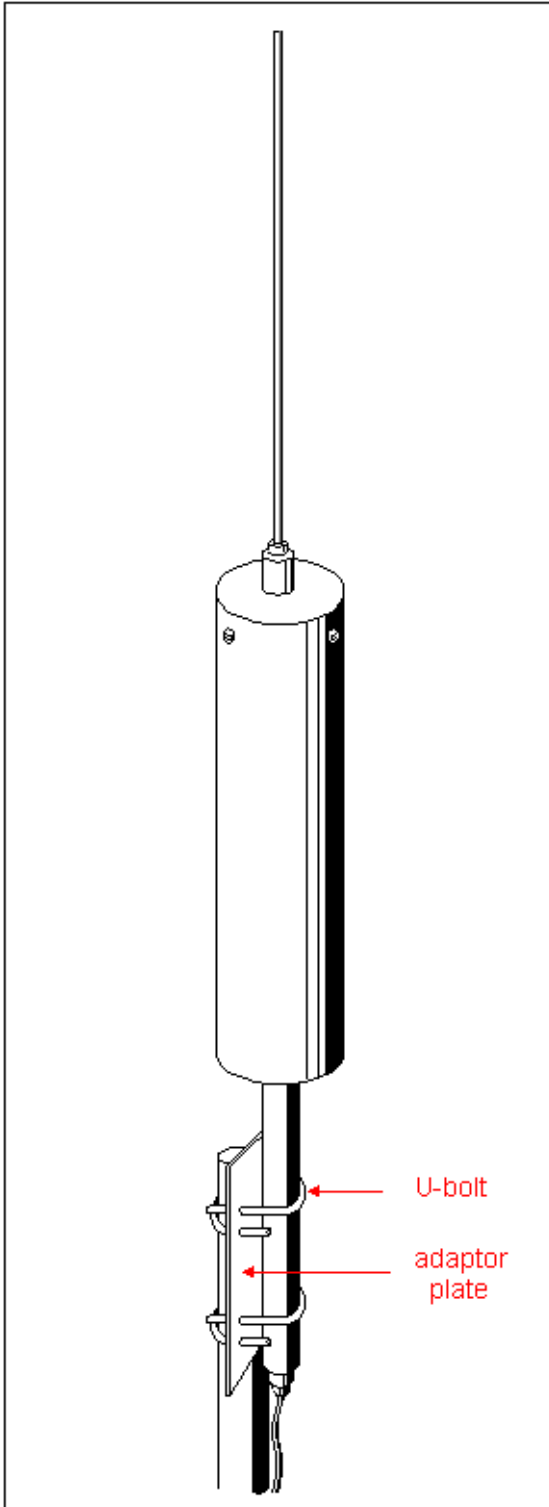

Figure 5.19

6 GROUNDPLANE ANTENNA (gamma fed)

Model DP-2F

This particular design of a dipole antenna is very popular in VHF applications because of its capability to be fine-tuned during tuning procedures. Tuning is accomplished by a so-called gamma matching system connected near the center of the dipole element. Gamma matching is based on the principle of delta match system where the transmission line can be directly connected near the center of a continuous halfwave conductor and fanned out and tapped at the point of most efficient power transfer.

The middle of a halfwave dipole is electrically neutral - meaning there is no RF voltage present so the outer conductor of the coax cable can be connected directly to the element at this point. The inner conductor of the coaxial cable carries an RF current so it is tapped into the dipole element at the matching point.

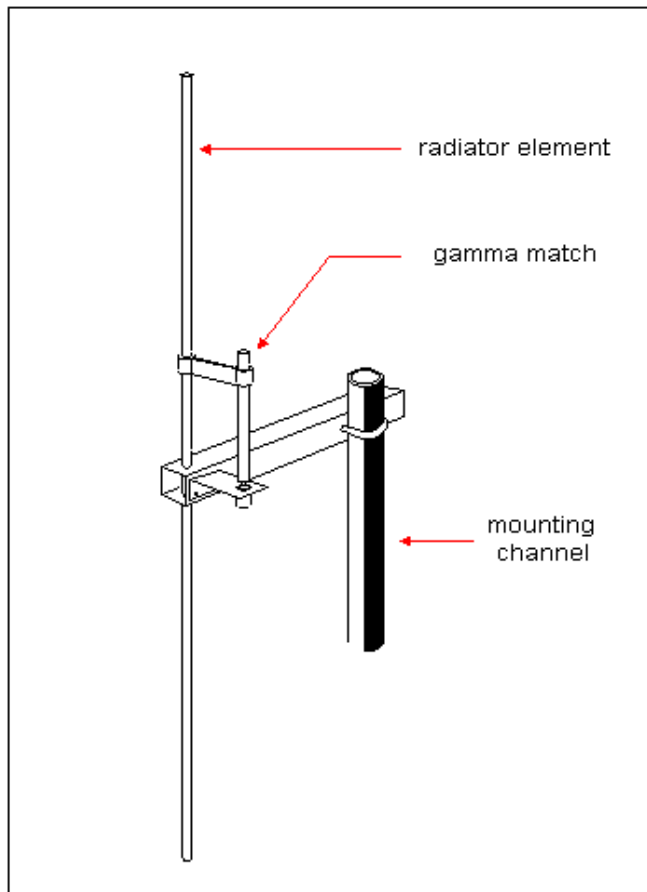

After a careful observation of this design you will notice that the center conductor of the coax cable is not directly connected to the dipole element but instead coupled via a short tube called "gamma tube". The combination of the short tube and the coaxial cable inside it provides the capacitance needed to cancel the inductance of the dipole element to attain an electrical balance. The gamma match therefore achieves two functions at the same time, that is to match the impedance of the transmission line to the impedance of the antenna and to couple the unbalanced coaxial cable to the symmetrical dipole element. This method makes it unnecessary to use a separate balancing transformer. Fine tuning of the antenna can be done by adjusting the shorting bar that connects the gamma tube to the dipole element until the lowest SWR response is achieved.

Model DP-2 is also used as a basic driven element for high gain Yagi and collinear antenna designs. Because the middle of the dipole element is electrically inactive, it does not require to be insulated from its mounting boom thereby simplifying the mechanical construction. Lightning protection for this antenna system is also improved because all the metallic parts of the antenna are grounded via its mast or tower.

The dipole design described in this chapter is designed to operate in the frequency band of 140-150 MHz. If properly tuned it exhibits an SWR of less than 1.4:1 over the entire band. It radiates its signal in an omni-directional pattern. It has a gain of 1 dB (unity gain) compared to a standard dipole reference.

This antenna is intended primarily for fixed installations. However, some radio operators were able to use it successfully in mobile operations by modifying its mechanical construction.

Some antenna constructors choose to build this antenna because it presents them deeper understanding of the electrical principles of antennas compared to other simpler designs like groundplanes or coaxial dipoles. If you are the experimenter type of radio operator then this design is for you.

Materials List		
Quantity	Specification/Description	Dimensions
1	Aluminum tube 3/8" id*	38" long
1	Aluminum tube 3/8" id*	6" long
1	Aluminum square channel	1" x 1" x 12"
1	Aluminum strip - see text for fabrication	1/2" x 4"
1	Coax cable RG-58/U	6"
1	BNC female connector	
2	Stove bolts - brass or GI	1/8" x 3/8"
2	Hex nuts - brass or GI	1/8" id
1	U-bolt with accompanying hex nuts and washers	
3	Self tapping metal screws	1/8" x 1/2"
Miscellaneous: Epoxy glue		

*id- inside diameter

Construction

The radiator element is made from 3/8 od* aluminum tube cut to a length of 38 inches. Drill a hole (1/16" diameter) through and through at the middle of its length (see Figure 6.2).

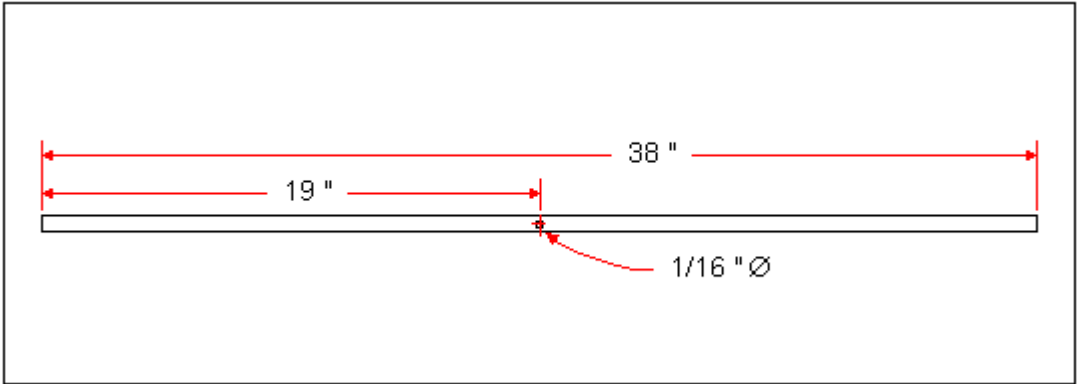

Figure 6.2 Drilling a hole through the middle point of the radiator element.

Next prepare the mounting channel by drilling a hole at one end (see Figure 6.3). The diameter of the hole must accommodate the aluminum tube that will be inserted into it. The hole is 3/8" and slightly oversized so that the tube will not be scratched upon insertion but not too loose as to sacrifice rigidity.

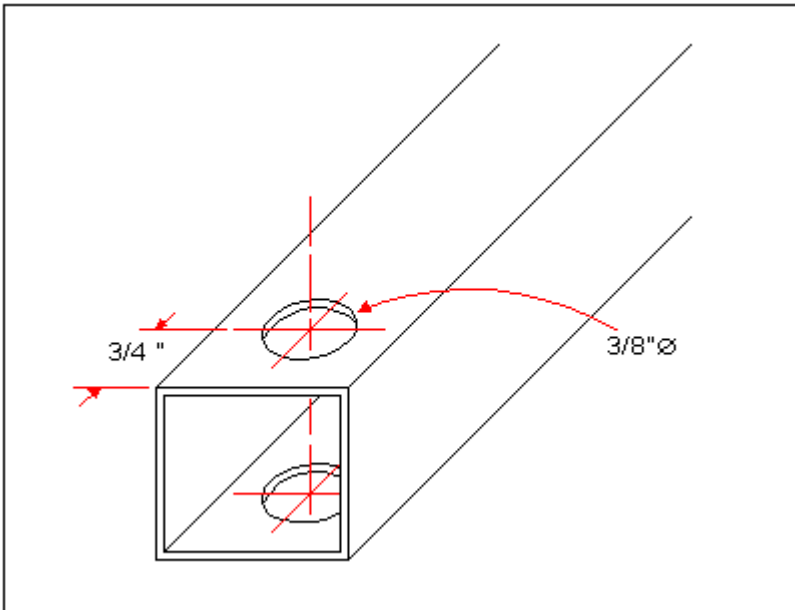

Figure 6.3 Preparing the mounting channel.

Next, drill two small holes (1/16" diameter) at one side of the channel perpendicular to the axis of the bigger hole (see Figure 6.4).

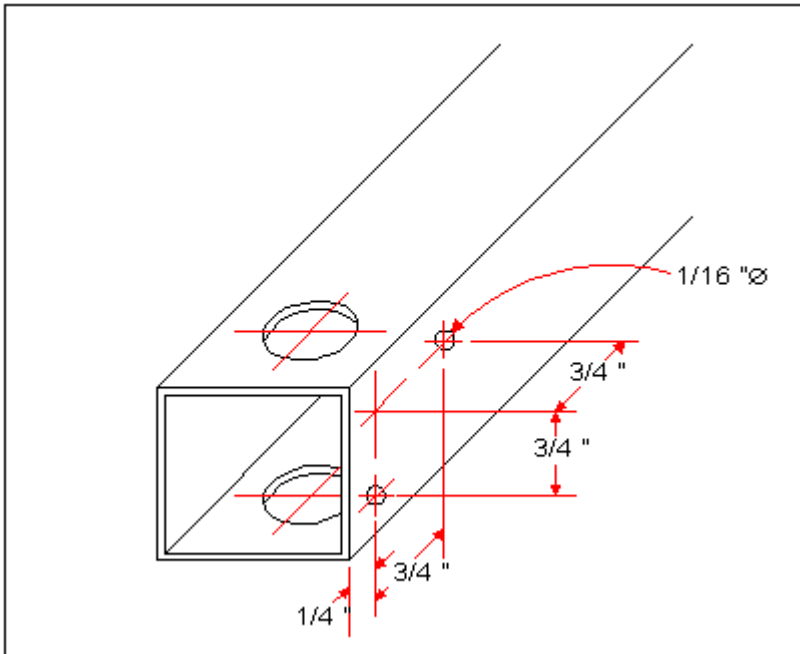

Figure 6.4 Drilling holes for the gamma mounting bracket.

Drill another pair of holes (3/16" diameter) at the same side but at the opposite end of the channel (see Figure 6.5). Drill the hole through and through. The size of the holes and the distance between them must conform to the dimensions of the U-bolt used.

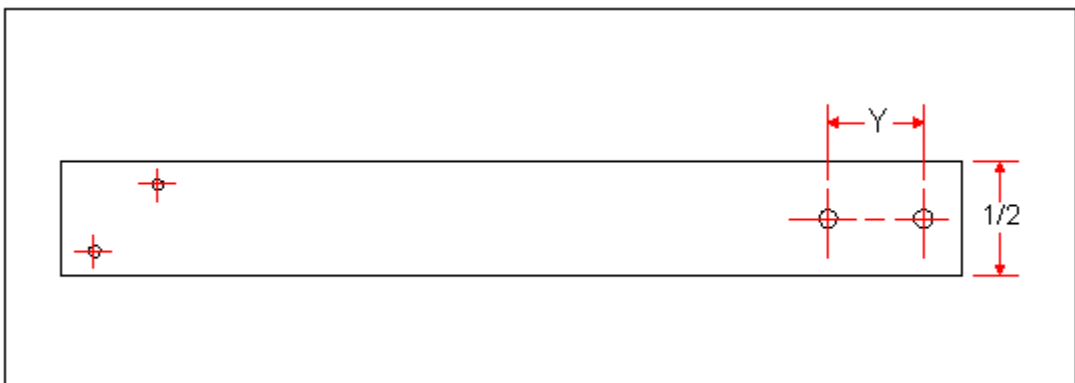

Figure 6.5 Drilling holes for the U-bolt at the opposite end .

Drill a single 1/8" diameter hole at the other side opposite to the two small holes (1/16" diameter). See dimensions in the following illustration.

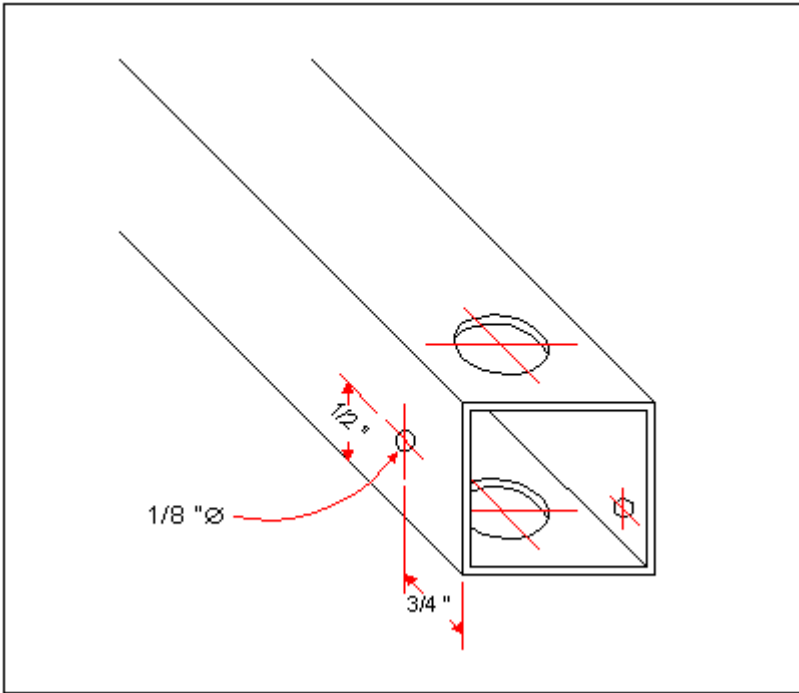

Figure 6.6 Drilling a single hole.

Insert the aluminum tube through the large hole and align the hole at its middle part to the 1/8" diameter hole at the side of the channel (see Figure 6.7).

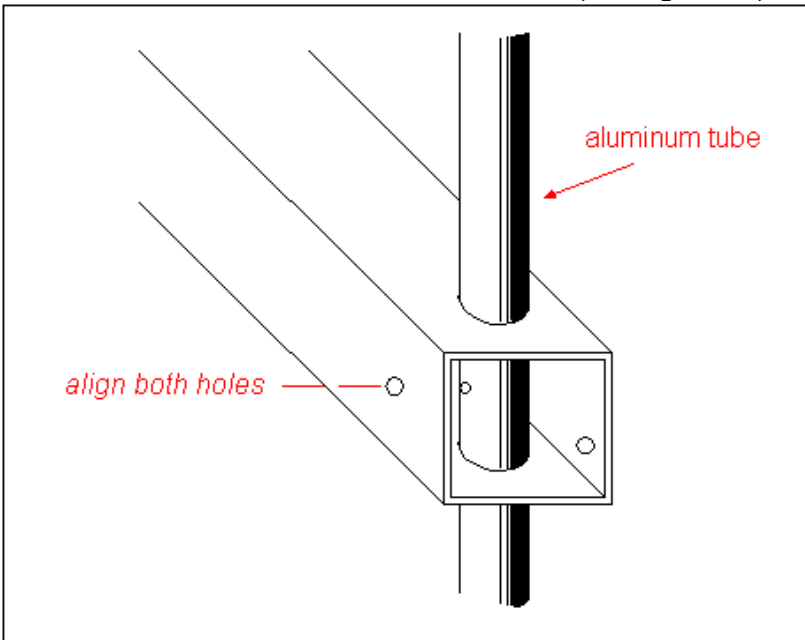

Figure 6.7 Inserting the aluminum tube into the mounting channel.

Insert a self tapping screw through the sidehole and forcibly screw it into the smaller hole of the tube inside (see Figure 6.8). Tighten the screw until the aluminum tube is rigidly held in the aluminum channel.

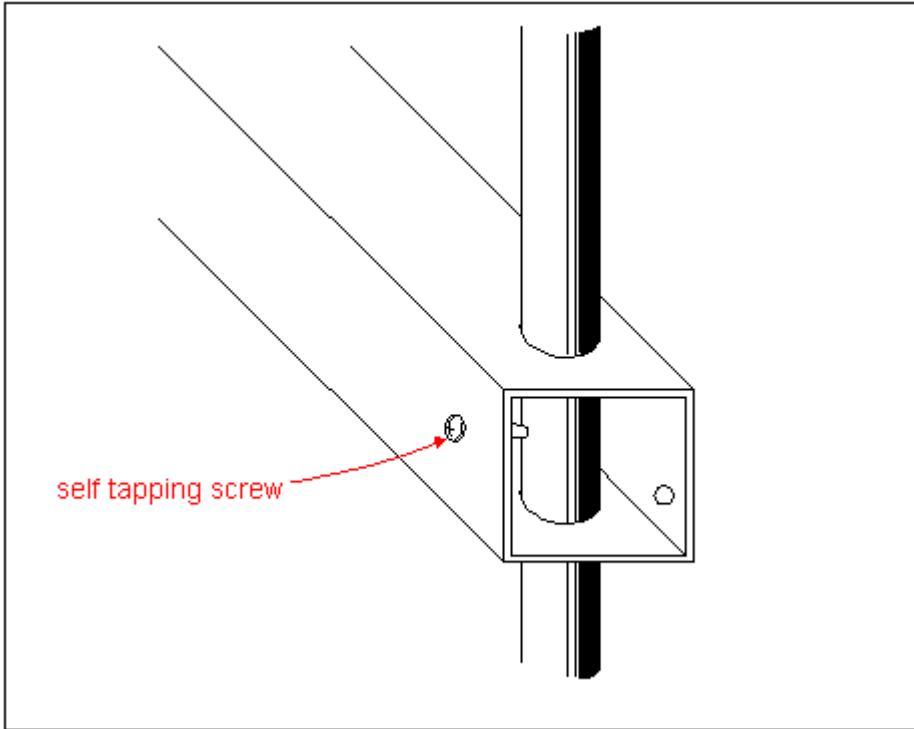

Figure 6.8 Locking the tube with a self tapping screw.

Prepare the feedpoint angle bracket. The bracket is cut from a small strip of aluminum and bent into a right angle. An alternative method is to saw off a portion of a 1" x 3" rectangular aluminum channel. This will give you a more durable bracket with a near perfect angle.

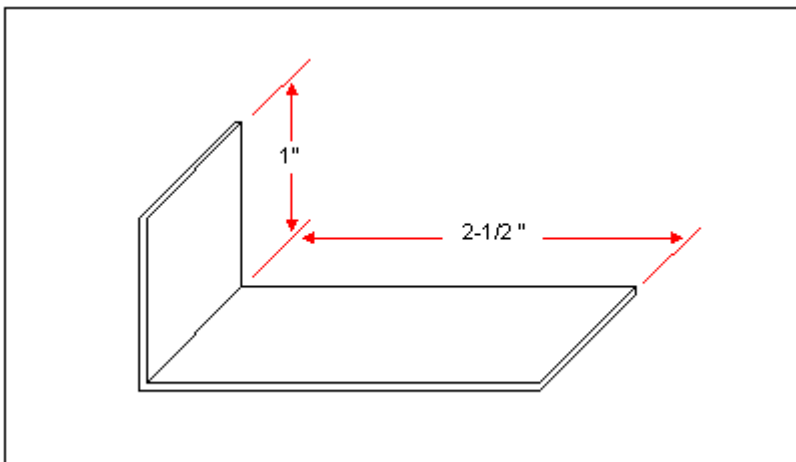

Figure 6.9 Preparing the feedpoint bracket (gamma mounting bracket).

Drill two small holes ($1/8$ " diameter) at one side of the angle bracket. Drill another hole at the other side of the bracket. This lone hole must be large enough to accommodate the BNC female connector (see Figure 6.10).

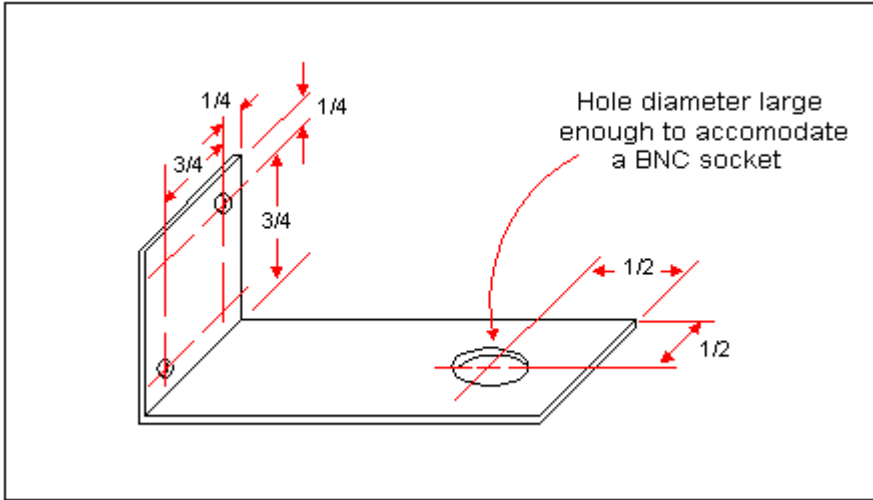

Figure 6.10 Drilling mounting holes in the bracket.

Attach the bracket into the mounting channel by screwing it with small self tapping screws (see Figure 6.11).

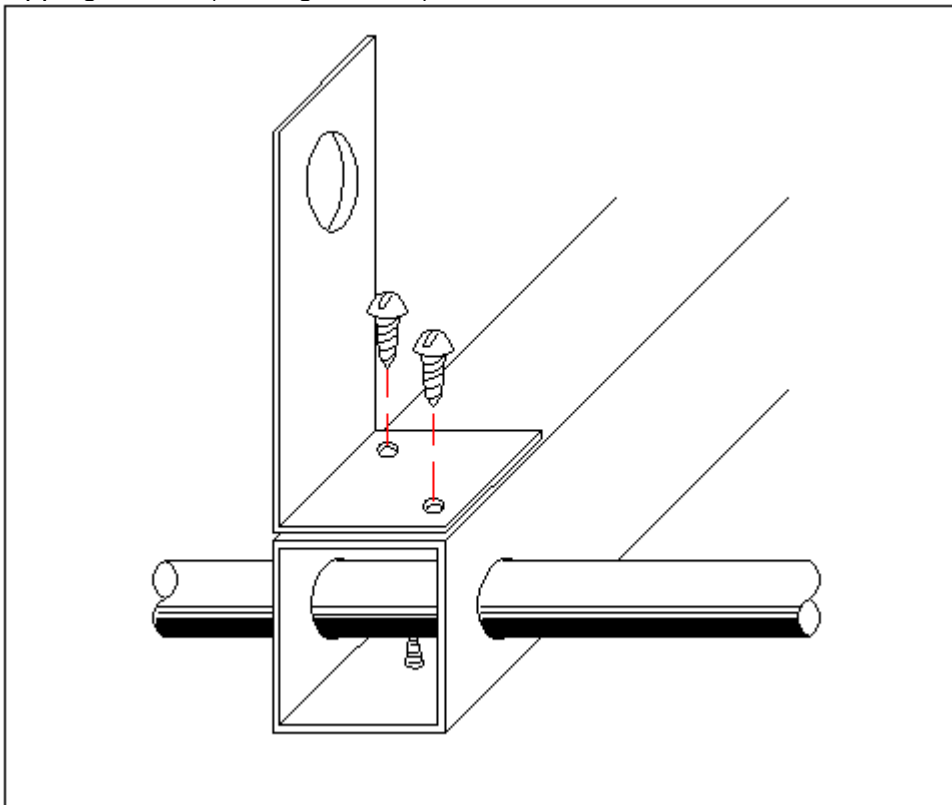

Figure 6.11 Fixing the feedpoint bracket on the mounting channel.

Insert the BNC female connector in an upside down position into the large hole of the feedpoint bracket and secure it with its nut (see Figure 6.12).

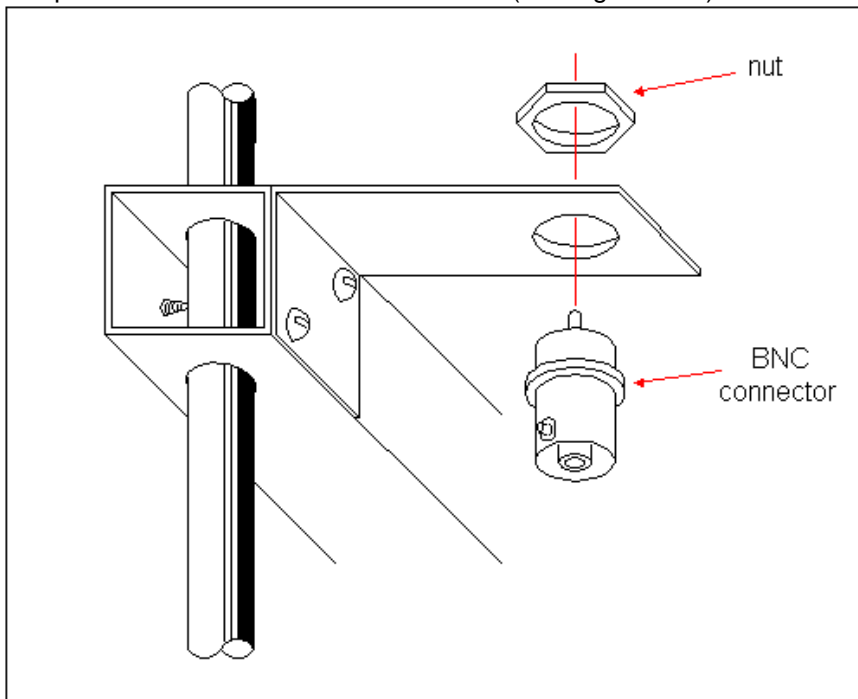

Figure 6.12 Installing the BNC connector into the feedpoint bracket.

Next step is to prepare the tuning clamp and the gamma matching tube. First, fabricate a flat strip from a scrap tube (about 4 inches long) by pressing it in a table vise until it is completely flattened. Cut about 4 inches of the flat strip and form both ends to a ring clamp by bending it around an aluminum tube. The ends must be formed to fit around the tube (see Figure 6.13).

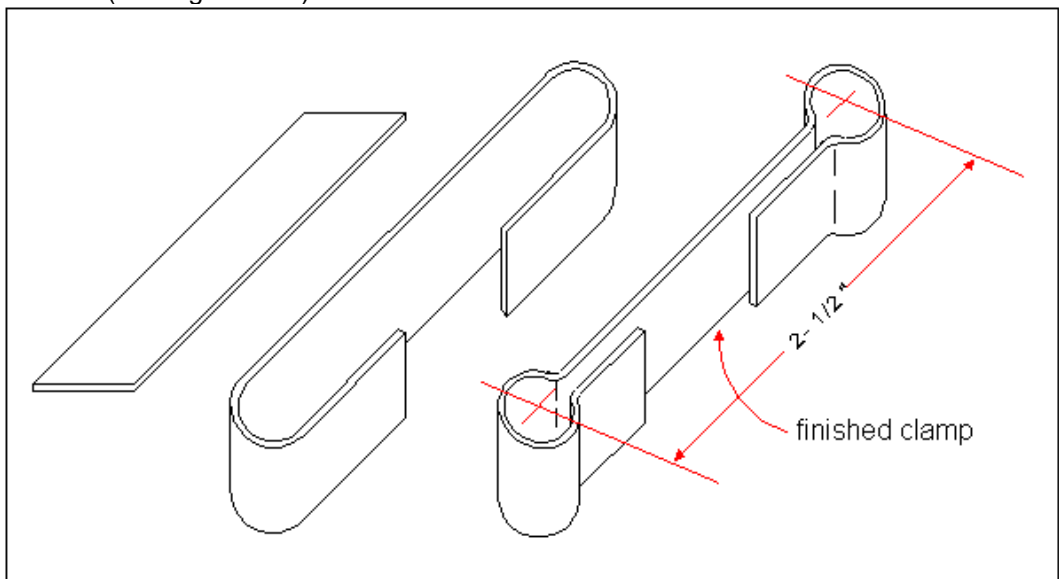

Figure 6.13 Preparing the tuning clamp.

Drill two holes (1/8" diameter) in the tuning clamp (see Figure 6.14).

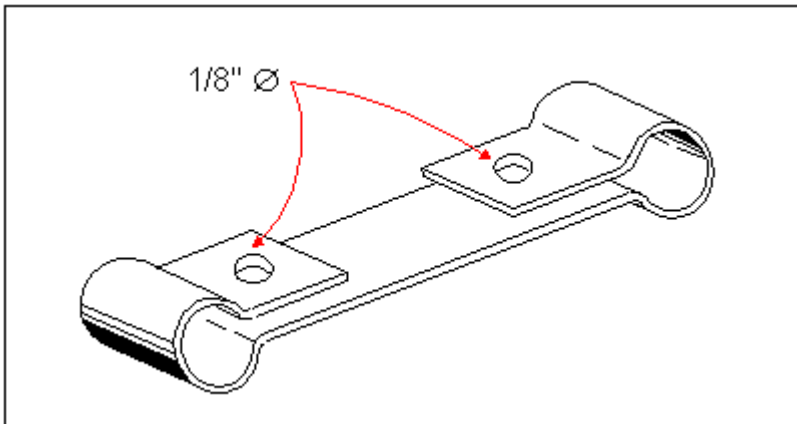

Figure 6.14 Drilling holes in the tuning clamp.

Insert the 6 inch long tube into one loop of the clamp and secure the clamp with a 1/8" x 3/8" stove bolt. Attach a nut to the bolt and tighten it lightly (see Figure 6.15). **Don't tighten this bolt too much at this time!**

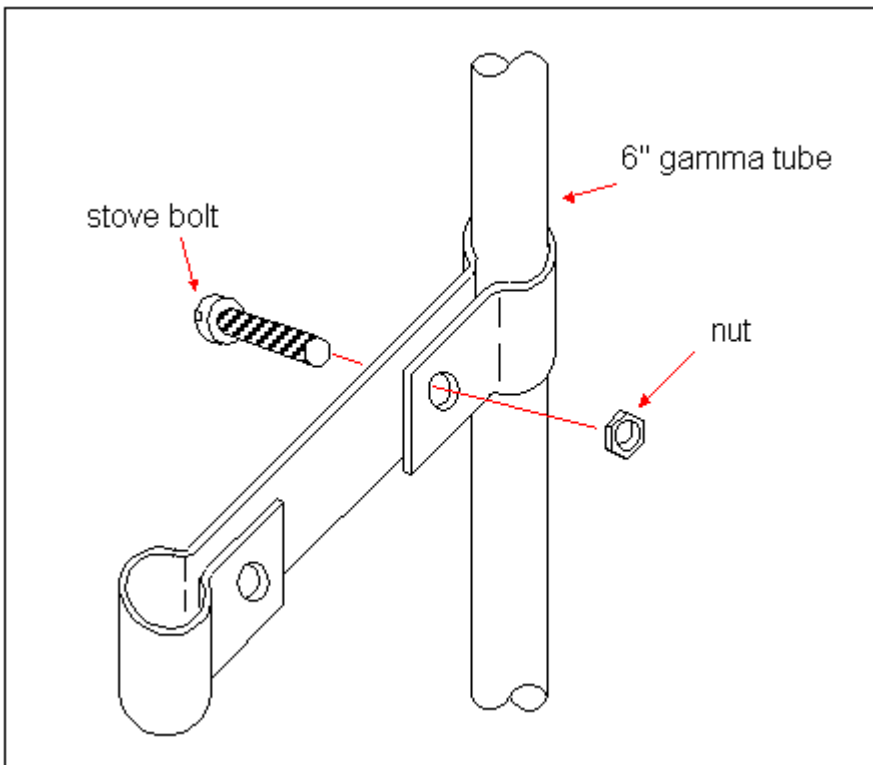

Figure 6.15 Inserting the 6 inch long gamma tube into the tuning clamp.

Waterproof the top end of the 6 inch gamma tube by inserting a substantial volume of cotton wad inside the open end. The cotton wad serves as a stopper for the epoxy. Place epoxy glue over the cotton wad inside. Let the epoxy set and dry (see Figure 6.16).

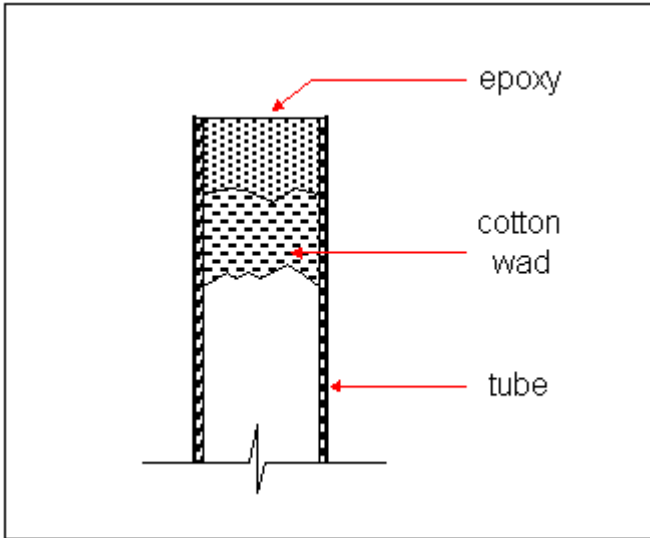

Figure 6.16 Sealing the top end of the gamma tube.

While the epoxy is drying, prepare the gamma match from a short length of **RG-8/U** coaxial cable. Cut a piece 6 inches long and remove its vinyl outer jacket and its braid. Cut away a small portion of the PE inner insulator exposing the copper conductor inside (see Figure 6.17).

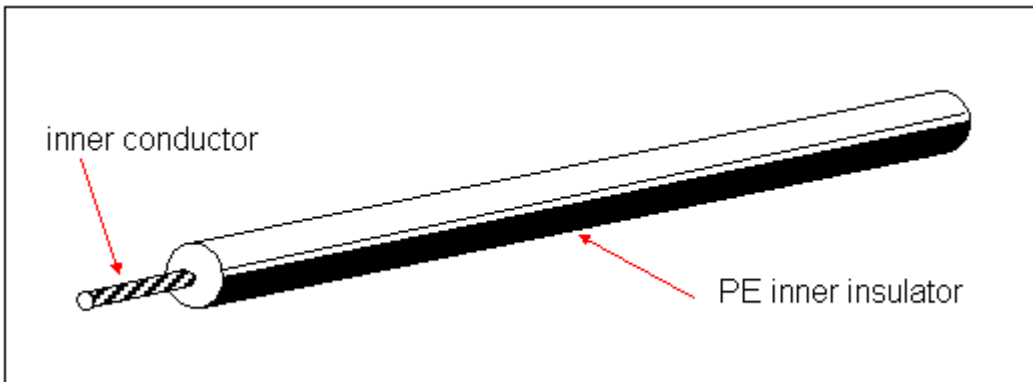

Figure 6.17 Preparing the gamma match from a short length of RG-8/U.

Solder the exposed copper conductor of the gamma match directly into the center pin of the BNC connector attached to the mounting channel.

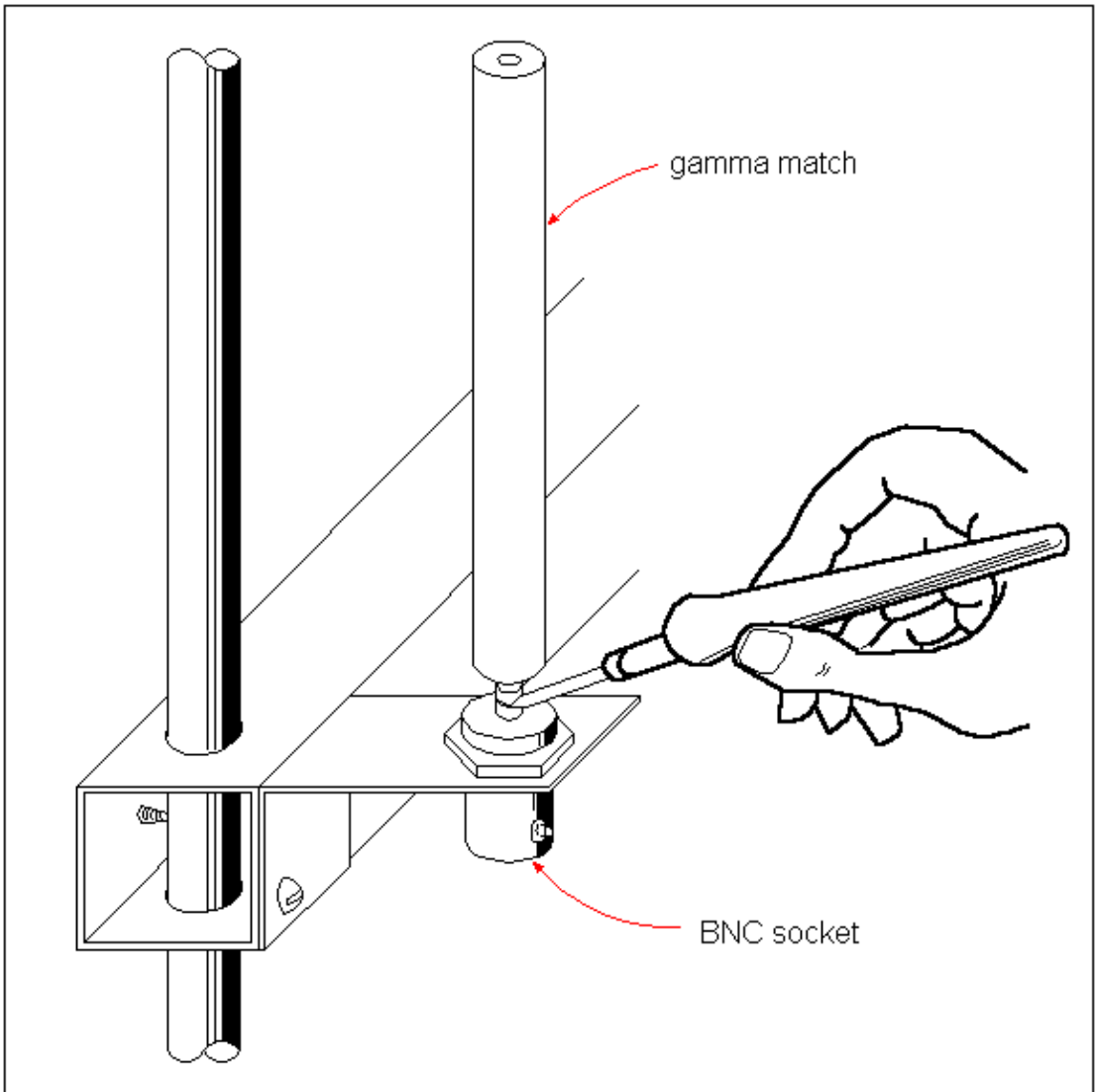

Figure 6.18 Soldering the gamma match into the BNC connector.

Next, carefully insert the free end of the tuning clamp into the radiator element (long tube) starting at the top end. As the tuning clamp is lowered down along with the gamma tube attached to it, insert the gamma match into the gamma tube (see Figure 6.19).

Stop the gamma tube just about 1/2 inch above plane of the angle bracket or just enough for the gamma tube to cover the whole PE insulator. Insert a bolt into the tuning clamp attached around the radiator element and tighten it lightly enough to hold the gamma matching assembly in place. The antenna is already mechanically ready at this point, it only needs to be tuned to resonance for proper operation.

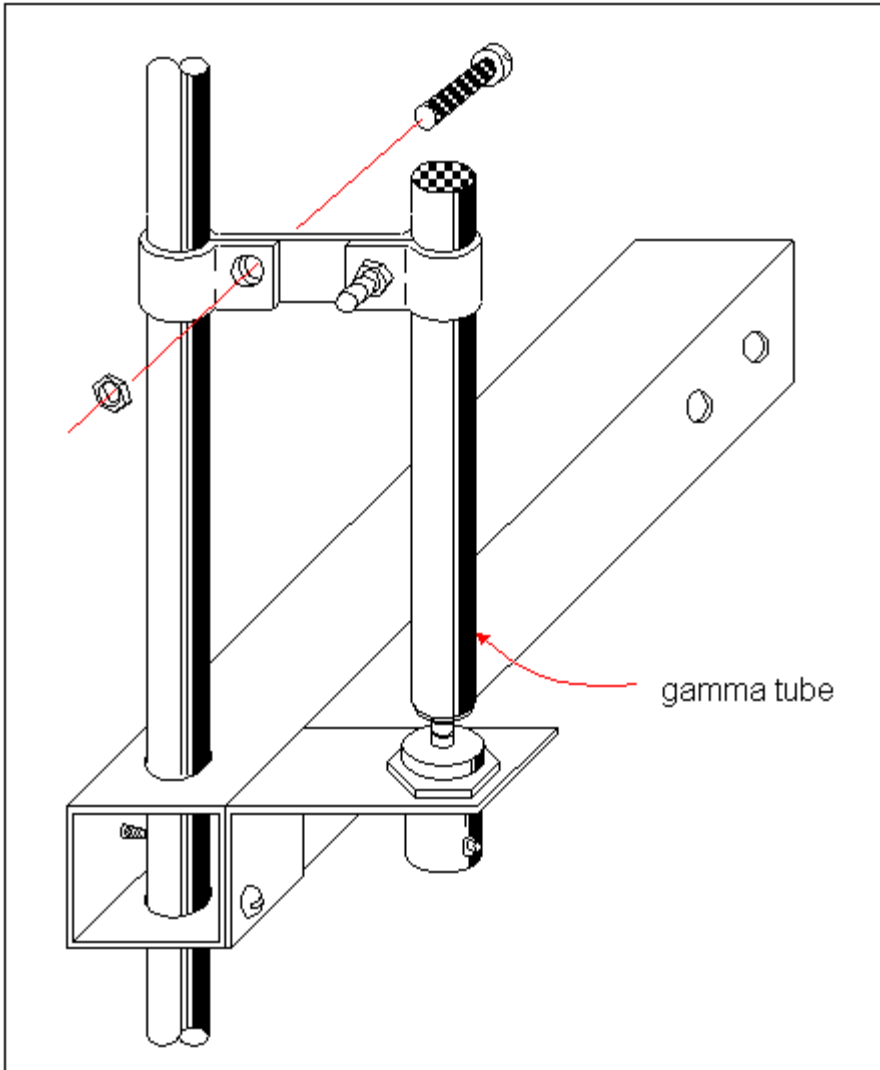

Figure 6.19 Assembling the gamma tube into the gamma match.

In tuning the antenna to resonance, install it to the mast or tower following Figure 6.1. Connect the coaxial cable to the BNC connector in the angle bracket and connect the other end to a suitable SWR meter. Connect a VHF transceiver to the SWR meter (usually marked 'transmitter') and set its frequency to either the center or extreme frequencies of the band. Key the PTT to transmit and read the SWR response.

To tune the antenna: move the tuning clamp and find the position where you can get the lowest SWR response for the center frequency and a relatively flat response curve over the entire band. Move the tuning clamp either lower or higher about 1/4 inch at a time (see Figure 6.20).

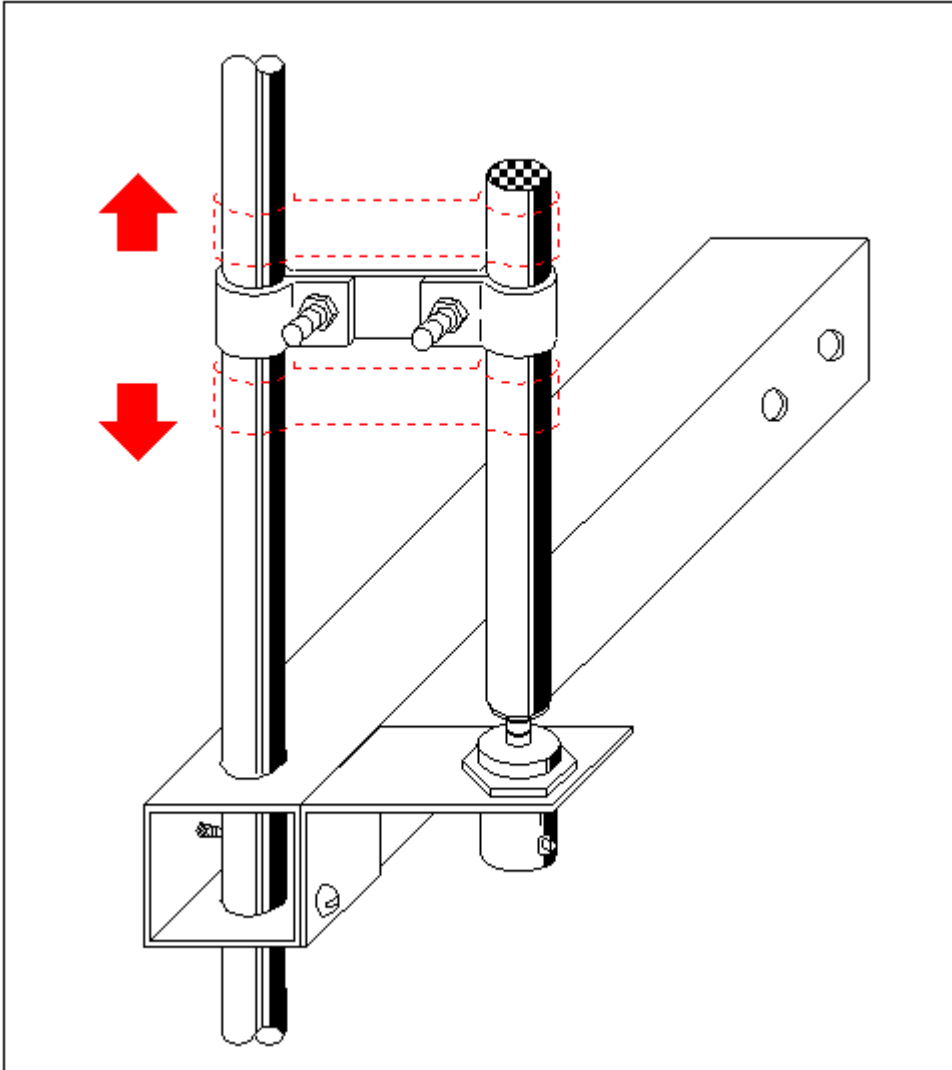

Figure 6.20 Raising or lowering the tuning clamp to find the best match.

If you have finally found the right position (after several trials) then you have successfully tuned the antenna to resonance. Tighten the nuts at the tuning clamp permanently and place a moderate amount of silicone sealant (RTV compound) around the open lower end of the gamma matching tube to seal it off from moisture and rainwater (see Figure 6.21).

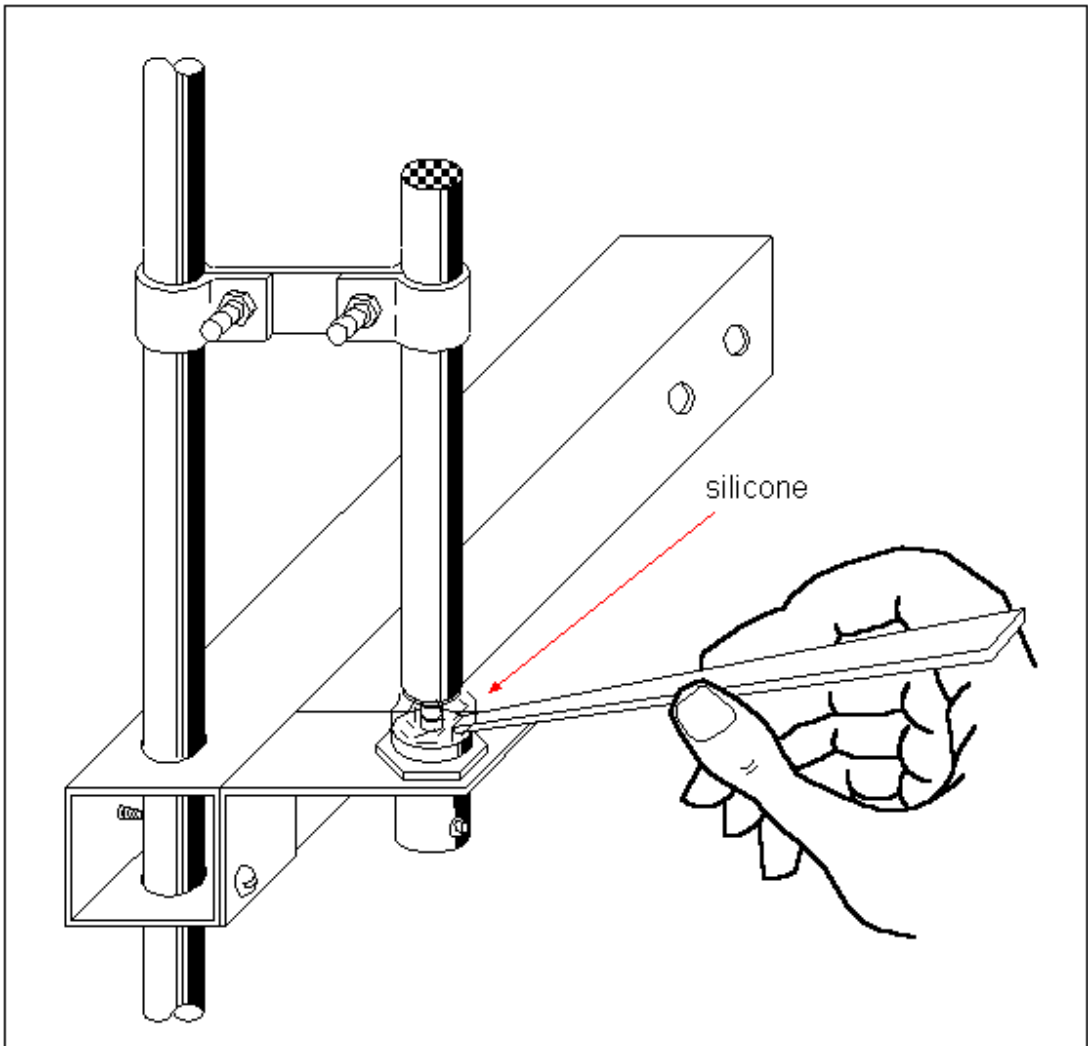

Figure 6.21 Sealing off the lower end of gamma tube with silicone.



IMPORTANT:

- Do not touch any part of the antenna while keying the rig or reading the SWR response.
- Do not move the tuning clamp while the transceiver is still transmitting.

7 QUADLOOP ANTENNA

Model QA-2F

In preceding chapters all of the various antenna designs presented are assemblies of linear halfwave (or approximately halfwave) dipole elements. On the other hand other element forms may also be used to effectively function as an antenna. One example is the quad antenna described in this chapter. This is the type of antenna with a radiating element made of a loop having a perimeter of one wavelength and used in much the same way as a dipole.

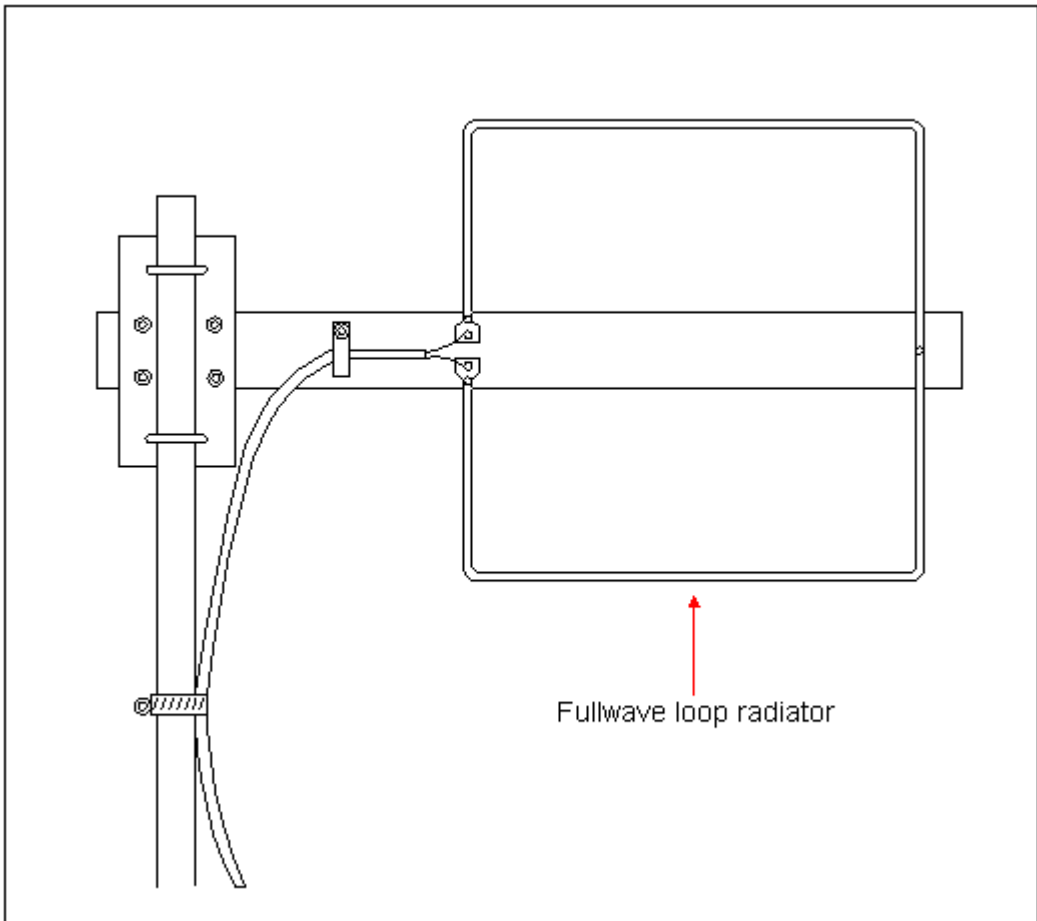

Figure 7.1 A quad loop antenna model QA-2F.

The quad antenna was originally designed in the late 1940's. Since then it has been the subject of controversy whether it performs better than a dipole. The debate continues but after some years several facts have become apparent. It was found out that the quad has a slight gain of approximately 2 dB over a dipole. It is also said to cover a wider area in the vertical plane and exhibits broadband characteristics.

The quad antenna model QA-2F is specifically designed to operate in the frequency band of 140-150 MHz. It displays a bi-directional radiation pattern with maximum radiation in the direction perpendicular to the plane of the loop. By carefully following the instruction for constructing this antenna you should be able to get an SWR response of less than 1.5:1 over the entire band.

Materials List		
Quantity	Specification/Description	Dimensions
1	Aluminum tube 3/8" id*	82 " long
1	Plastic plate 1/2 " thick	32" long
2	Stove bolts - brass or GI	1/8" x 3/8"
3	Stove bolts - brass or GI	1/8" x 1"
4	Stove bolts - brass or GI	3/16" x 1"
2	U-bolts with accompanying hex nuts and lockwashers	
1	Plastic C-clamp - enough to hold a 3/8" cable	
1	Self tapping metal screw	1/8" x 3/8"
2	Eye terminals - vinyl insulated	
4	Plain washers - 1/8" id*	
1	Hose clamp - enough to hold a 1-1/2" tube	

*id- inside diameter

Construction

First, prepare the plastic mount with dimensions shown in Figure 7.2.

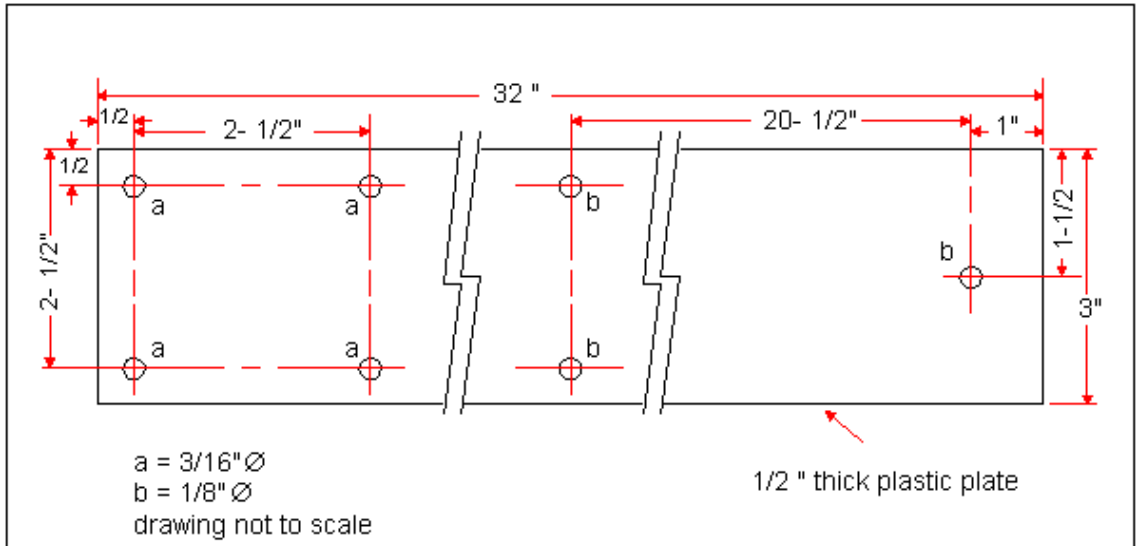

Figure 7.2 Plastic mount dimensions.

Next, prepare the metallic mast adaptor. As shown in the following illustration, the distance between one pair of 3/16" holes at the extreme ends is equal to the distance between the threaded ends of the U-bolt used (see Figure 7.3).

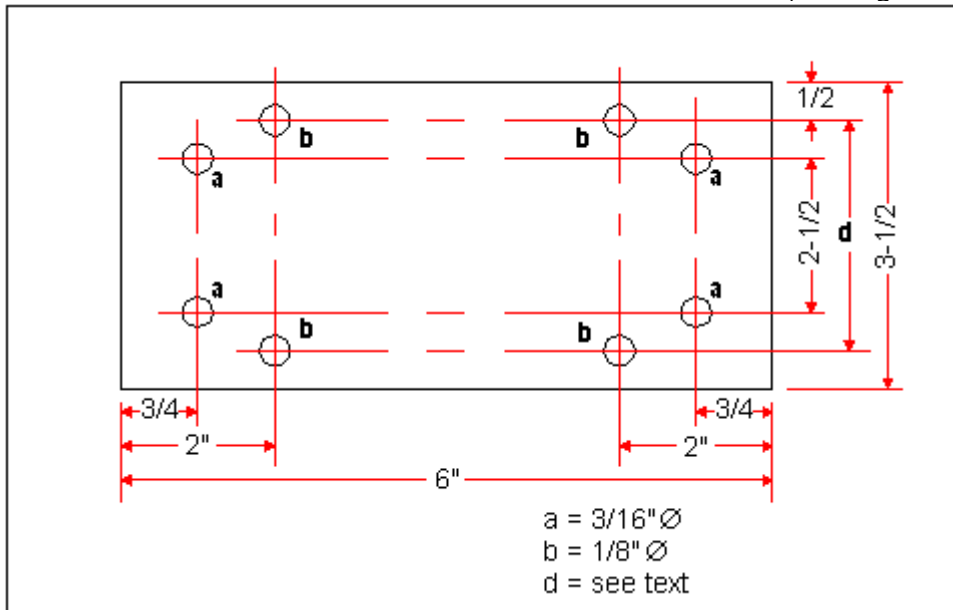

Figure 7.3 Mast adaptor dimensions.

Join the two plates together using four $\frac{3}{16}$ " x 1" stove bolts made of rust resistant materials (e.g. brass or stainless steel). Do not forget to include a lockwasher in each bolt (see Figure 7.4).

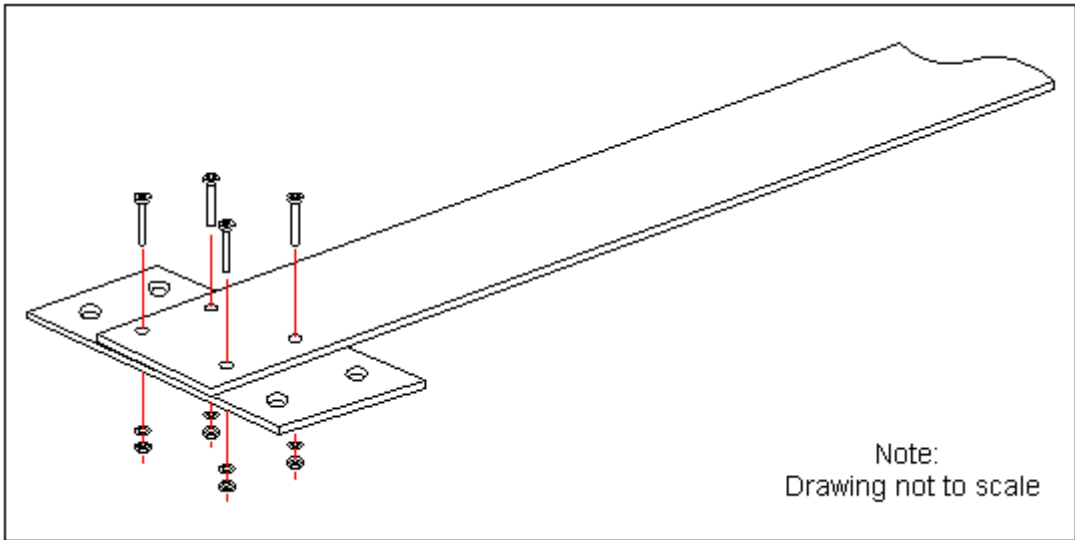

Figure 7.4 Joining the two plates together with stove bolts.

Bend the aluminum tube into a square loop with equal sides using a suitable tube bender (see Figure 7.5). Cut away the excess tube.

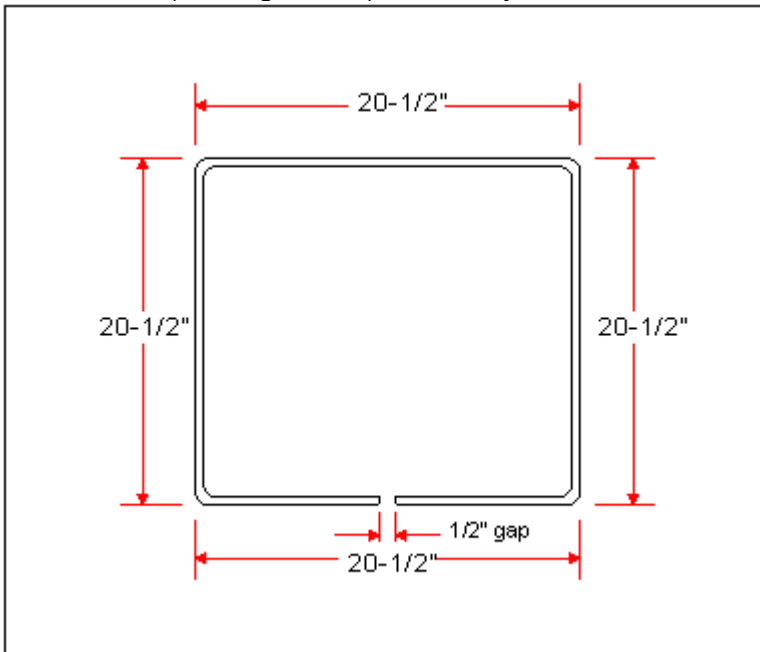

Figure 7.5 Forming the tube into a square loop.

Flatten a small portion at both ends of the tube and drill a hole (1/8" diameter) in each flattened end (see Figure 7.6).

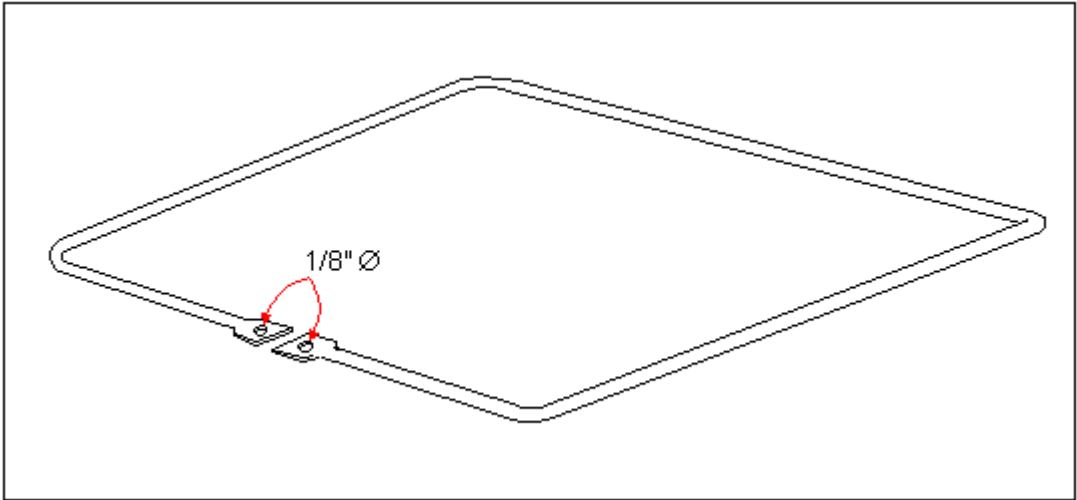

Figure 7.6 Flattening and drilling the ends of the tube.

Drill additional holes (1/8" diameter) in the tube as shown in the following illustration (Figure 7.7). The holes must be drilled through and through. Be careful in drilling the holes to avoid deforming the tube.

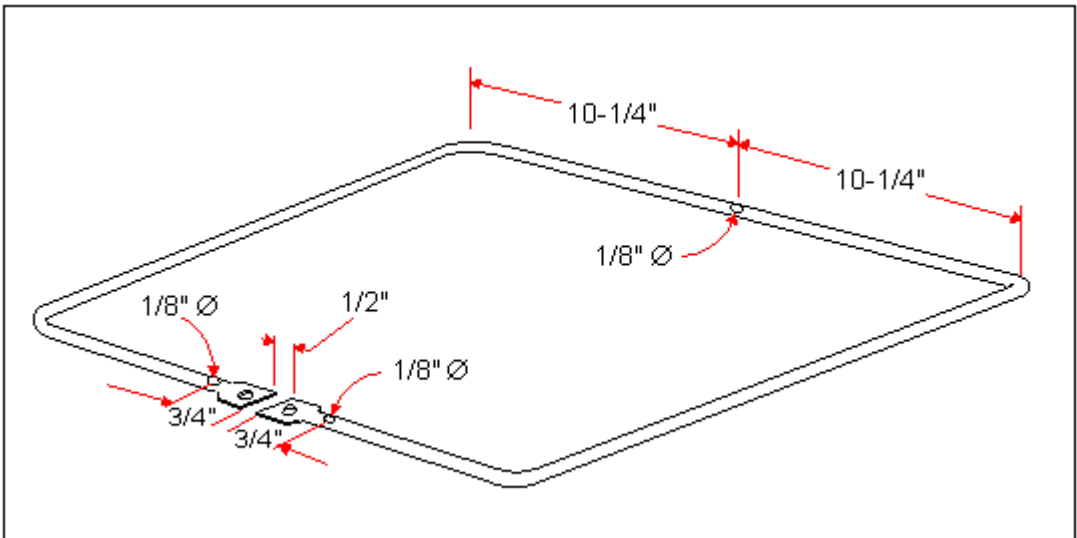

Figure 7.7 Drilling additional holes in the tube.

Insert two stove bolts (1/8" x 3/8") through the holes at both ends of the loop and attach the necessary hardware as shown in Figure 7.8.

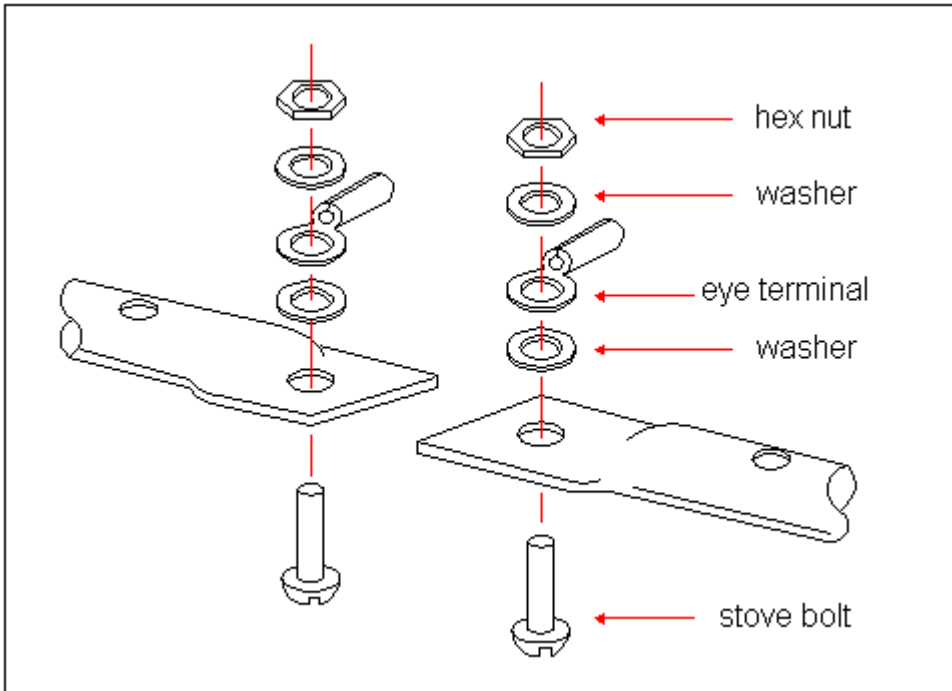

Figure 7.8 Installing the necessary hardware at both ends of the tube.

Attach the prepared loop into the plastic mounting plate by bolting it through the 1/8" diameter holes as shown in the following illustration. Use 1/8" x 1" stove bolts (brass or stainless steel). See Figure 7.9.

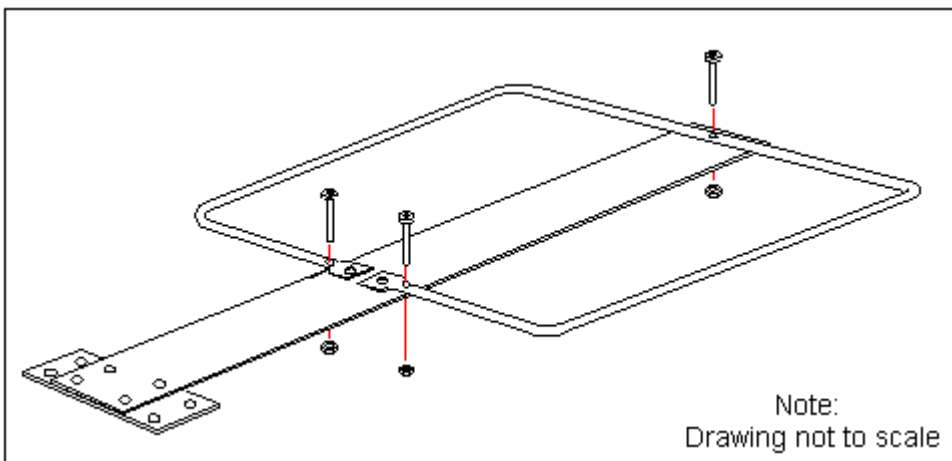

Figure 7.9 Fixing the loop on the plastic mount.

Prepare one end of the coax cable by separating the inner conductor from the copper braid. Solder the two conductors to the two eye terminals in the loop. The braid is customarily connected to the lower terminal (see Figure 7.10).

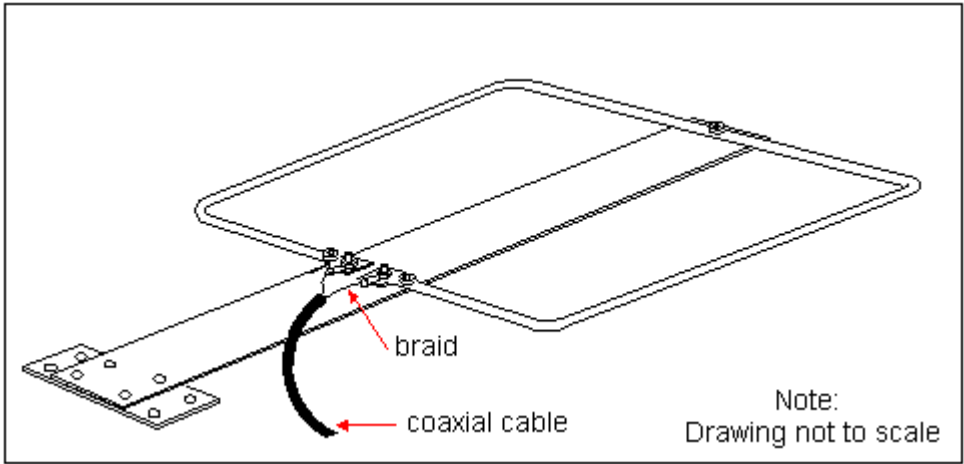

Figure 7.10 Connecting the coaxial cable to the loop element.

Clamp the coaxial cable to the plastic mounting plate (see Figure 7.11).

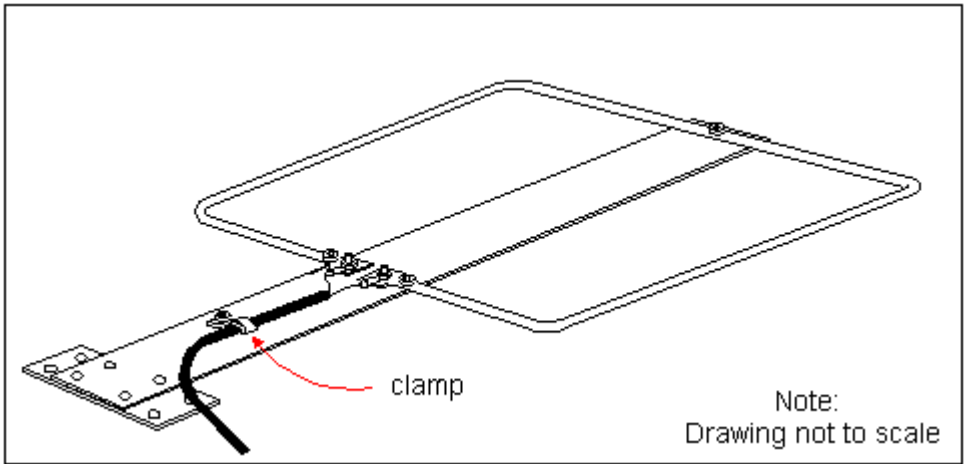

Figure 7.11 Clamping the coaxial cable to the plastic mount.

Installation of QA-2F

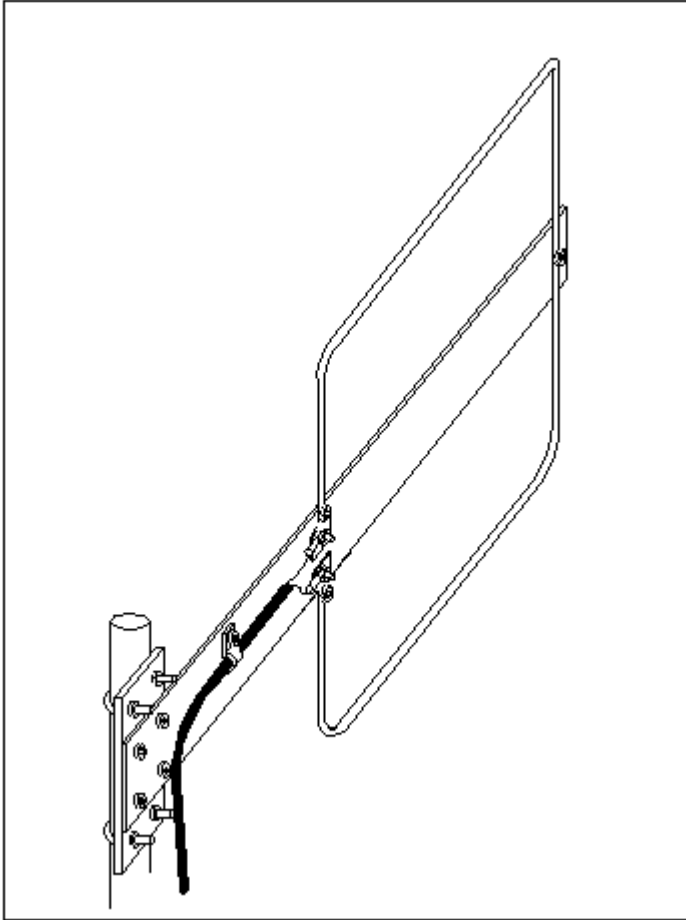

Figure 7.12 Installing the QA-2F to the mast.

8

DISCONE ANTENNA

Model CD-2W

Most of the antenna designs described in the preceding chapters are all suitable for VHF work requiring omni-directional pattern of radiation. Also in the mechanical viewpoint, these designs are simple and easy to construct which makes them very popular among radio operators. However all of them have a limited bandwidth of 140-150 MHz. If one attempts to operate his transceiver outside these frequency limits (assuming he has a wideband transceiver) the signal response becomes weaker as the operating frequency of the transceiver is moved farther away from the operational bandwidth of the antenna. At the same time the SWR in the transmission line increases and can reach an intolerable point which may cause damage to the transceiver. Although this handicap can be avoided by using a different antenna tuned to a different frequency band, the process of changing antennas everytime the operator changes his operating band becomes time-consuming and cumbersome. This problem can be solved by using a discone antenna described in this chapter.

The discone antenna is a broadband antenna. Meaning it can operate over a wide range of frequencies. Theoretically, a properly designed discone antenna can operate up to a frequency 10 times the value of its lowest operational frequency. Specifically speaking, if a discone antenna is designed to operate with a lowest operational frequency of 140 MHz, then it can be conveniently used up to 1.4 Gigahertz! The lowest operational frequency is called cut-off frequency. Below this frequency the SWR will increase rapidly.

Amazing! Well, a discone antenna can achieve that because it functions more like a transformer than a conventional antenna. It couples the low impedance transmission line to the higher impedance of free space. Its signal pattern is similar to that of a quarterwave groundplane antenna. Radiowaves from the transmission line emerge at the feedpoint (cone apex) and travel along the antenna surface to the edges of the cone and disc. In designing the discone, the dimensions of the antenna are carefully computed so as to make the impedance at its edges similar to that of free space. Naturally the discone radiates a signal because there is a maximum transfer of energy when impedances are matched.

The discone antenna described in this chapter is made of wire screen mesh. This material is purposely used to minimize the effect of wind to the antenna. The thin metal strips used to clamp the two overlapping edges of the cone is for mechanical reasons only- the RF waves travel down to the cone edge and not around it, so an electrical connection is not important.

This unit has an operational frequency bandwidth of 140 MHz up to 1.4 Gigahertz although best results can be obtained if its use is limited up to 1 Gigahertz only. SWR is measured to be less than 2:1 over the entire bandwidth. Power gain is 1 dB (unity gain) and its installation is fixed. The discone antenna does not need tuning after construction. It is also popular for use in automatic scanning wideband monitors.

SCALED DOWN APPEARANCE

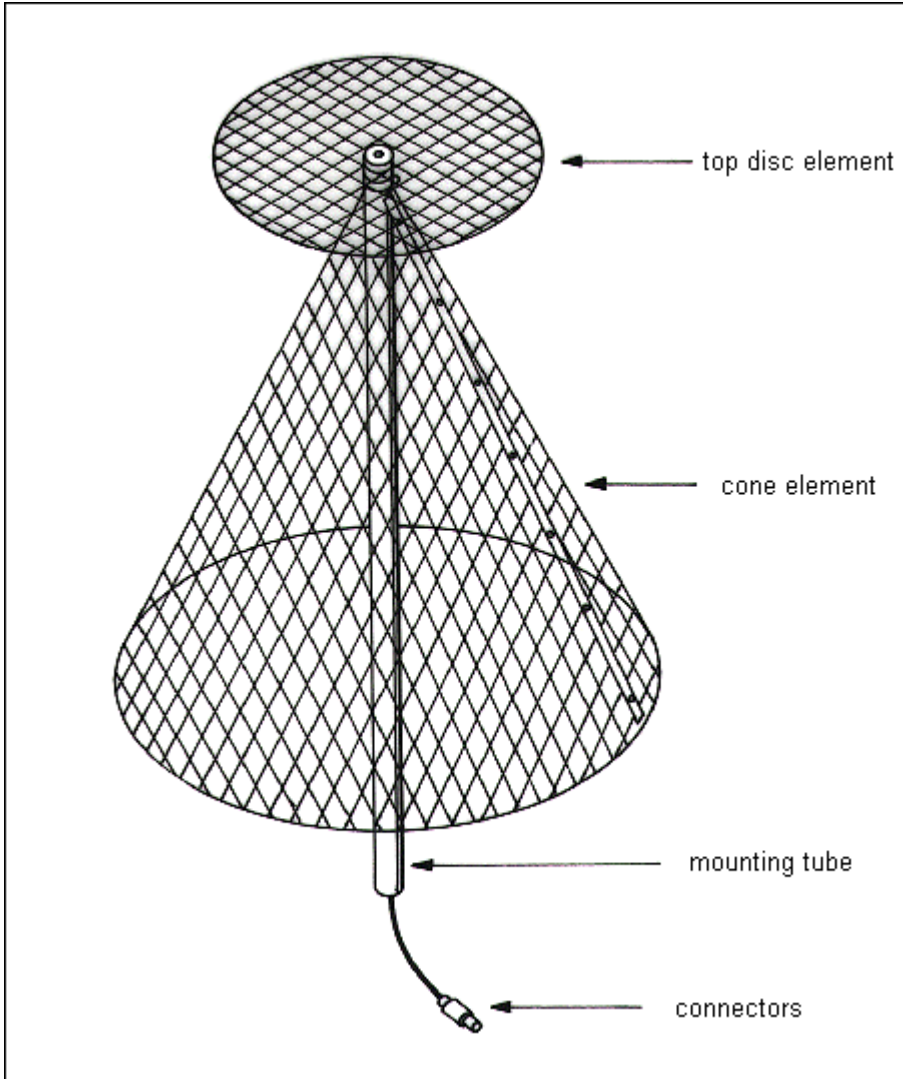

Figure 8.1

Materials List

Quantity	Specification/Description	Dimensions
1	Aluminum or GI wire screenmesh medium gauge - enough to support itself without reinforcement	
1	Aluminum tube 1" id*	25" long
1	PL-259 VHF male connector	
1	PL-258 VHF straight connector	
1	Coaxial cable RG-58/U	30" long
2	Eye terminals 1/8"	
1	Washer - aluminum (customized dimensions see text)	
1	Plastic bushing (customized dimensions see text)	
1	Stove bolt - brass or GI	1/8" x 1-3/4"+
1	Hex nut 1/8" id*	
1	Hose clamp - stainless steel	1-1/2" diameter
1	Metal plate 1/8" thick	3" x 6"
2	Aluminum strip gauge 14 or 16	1/2" x 22"
4	U-bolt with hex nuts and lock- washers	

*id- inside diameter

Construction

First, prepare the customized aluminum washer to be used as a disc holder. Machine it from a thick aluminum plate or rod following the dimensions shown in Figure 8.2.

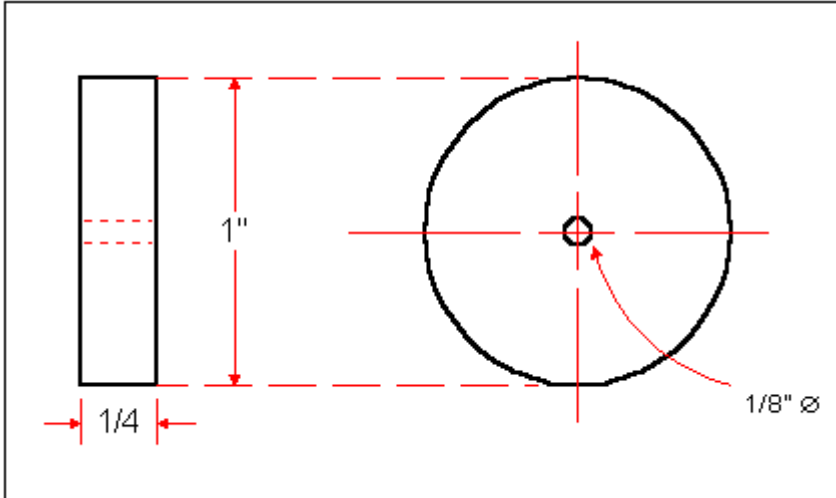

Figure 8.2 Customized aluminum washer dimensions.

Next, prepare the plastic bushing from a small piece of engineering plastic rod with the required diameter. Machine it according to the dimensions shown in Figure 8.3.

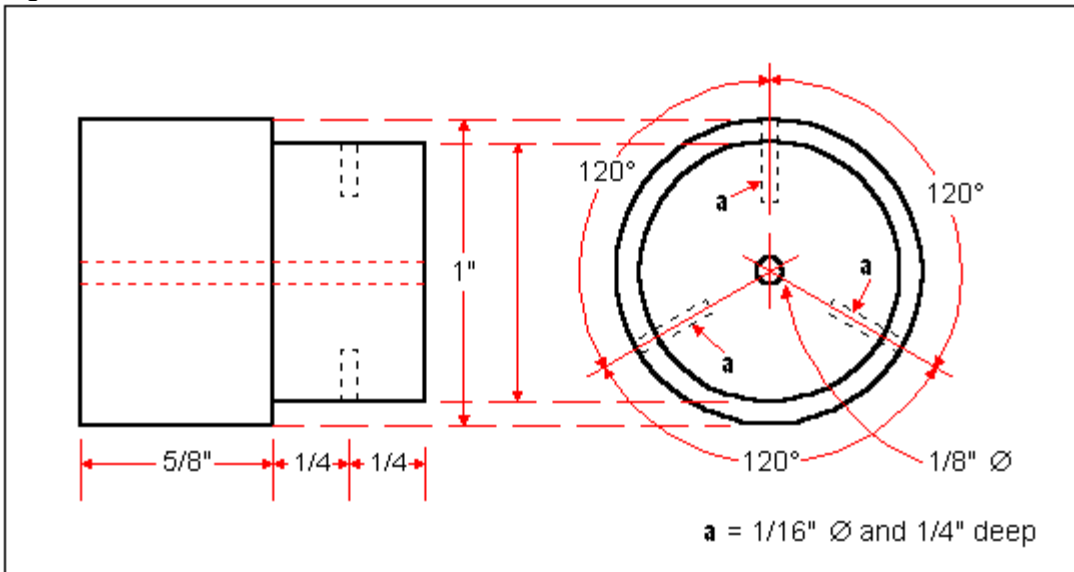

Figure 8.3 Plastic bushing dimensions.

Next, prepare the aluminum mounting tube. The tube must be 1" in diameter and 25 inches long. Drill three holes (1/8" diameter) around one end of the tube with the holes equally spaced between each other (see Figure 8.4).

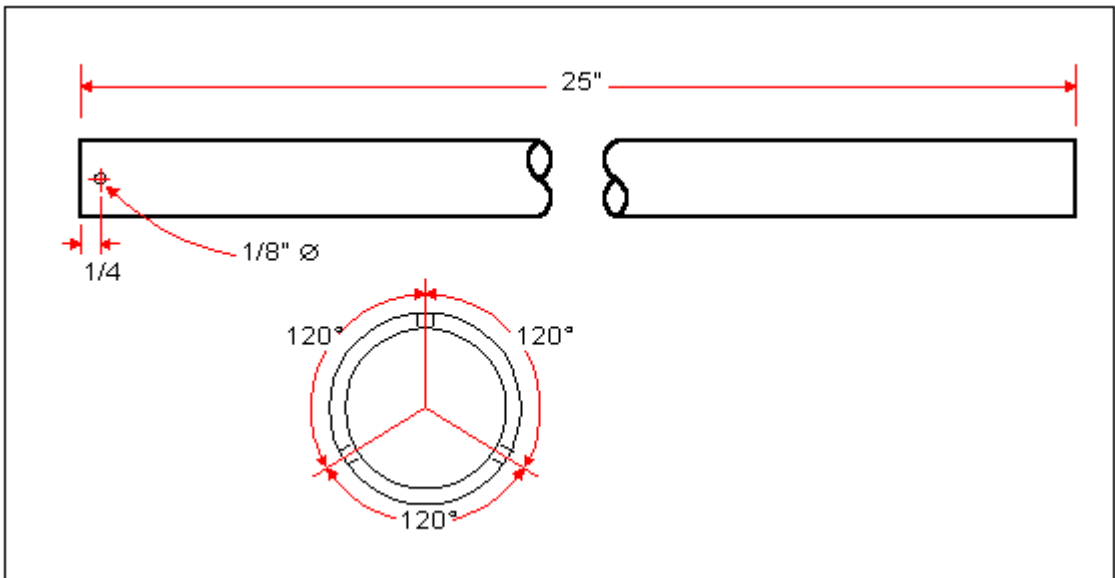

Figure 8.4 Drilling holes at one end of the mounting tube.

Drill a single hole (1/8" diameter) at the same end but slightly lower than the first three holes (see Figure 8.5). This hole will accommodate the screw to hold the coaxial braid inside the tube as described later in the final steps.

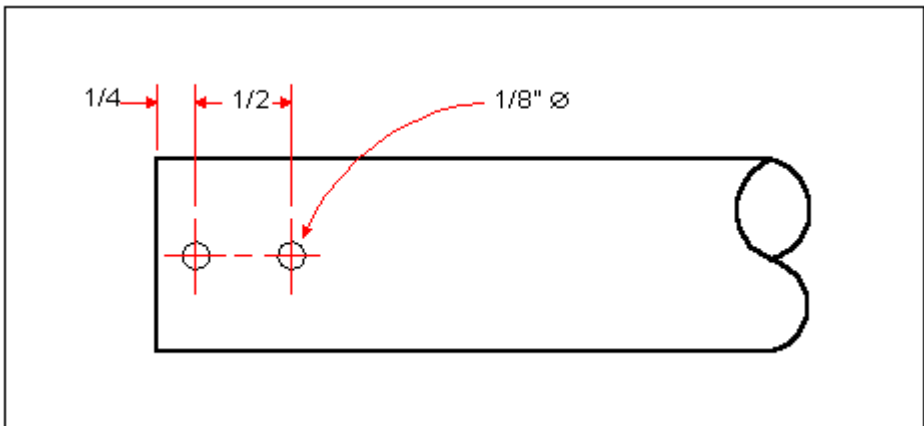

Figure 8.5 Drilling the hole which accommodates the coaxial braid lockscrew.

Preparing the disc and cone

Cut the disc element from the aluminum screen mesh using a suitable tinsnip (see Figure 8.6).

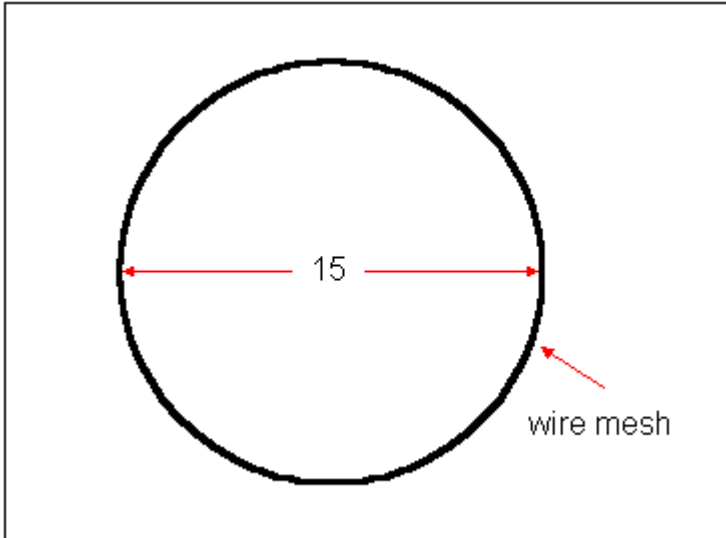

Figure 8.6 Disc element dimension.

Next, prepare the cone element from a similar material. Follow the dimensions shown in Figure 8.7.

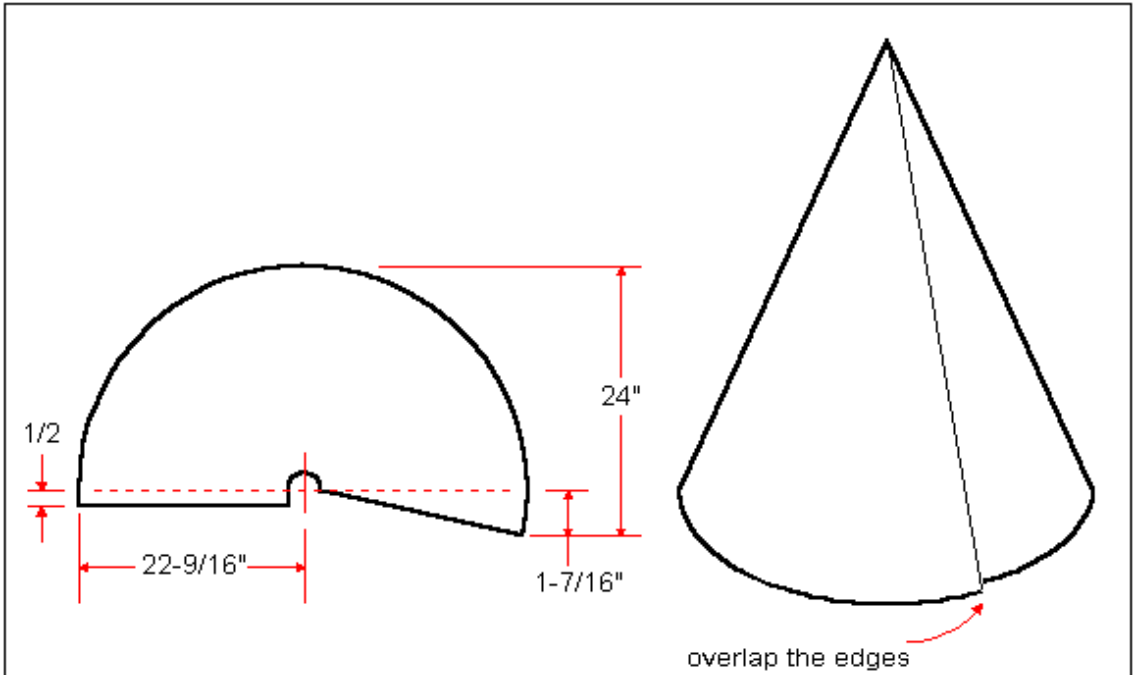

Figure 8.7 Cone element dimensions.

Prepare the aluminum strips according to the dimensions shown in Figure 8.8. These two strips will be used to clamp the two overlapping edges of the cone permanently.

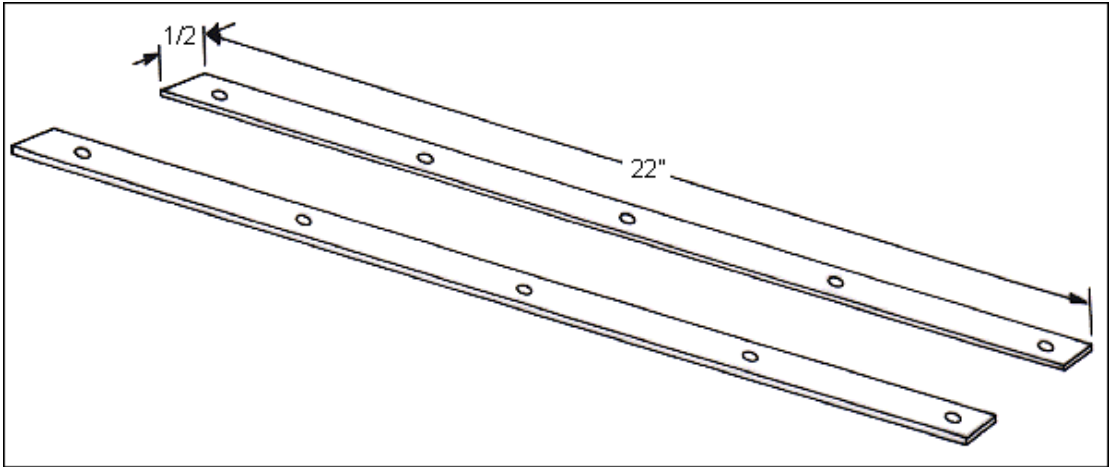

Figure 8.8 Preparing the clamping strips.

Place one strip along the overlapping edges under the cone and place the other strip over the overlap outside the cone. Align the holes in both strips and rivet the two pieces together. The rivet must pierce through the two overlapping edges (see Figure 8.9). The riveted strips must sandwich the screen mesh and hold the cone form rigidly.

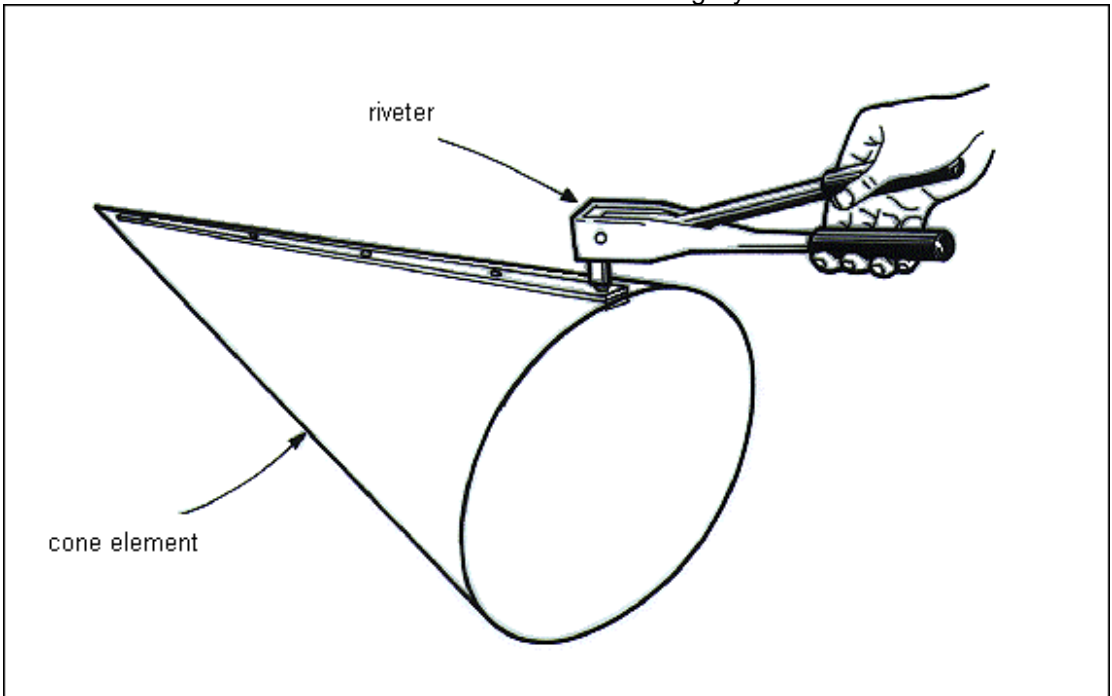

Figure 8.9 Riveting the clamping strips.

By using a tinsnip, make crosscuts on the apex of the cone to make a hole large enough for the mounting tube to go through. Follow the illustration in Figure 8.10 carefully . The cuts must result to an opening equal to the diameter of the tube - around 1 inch.

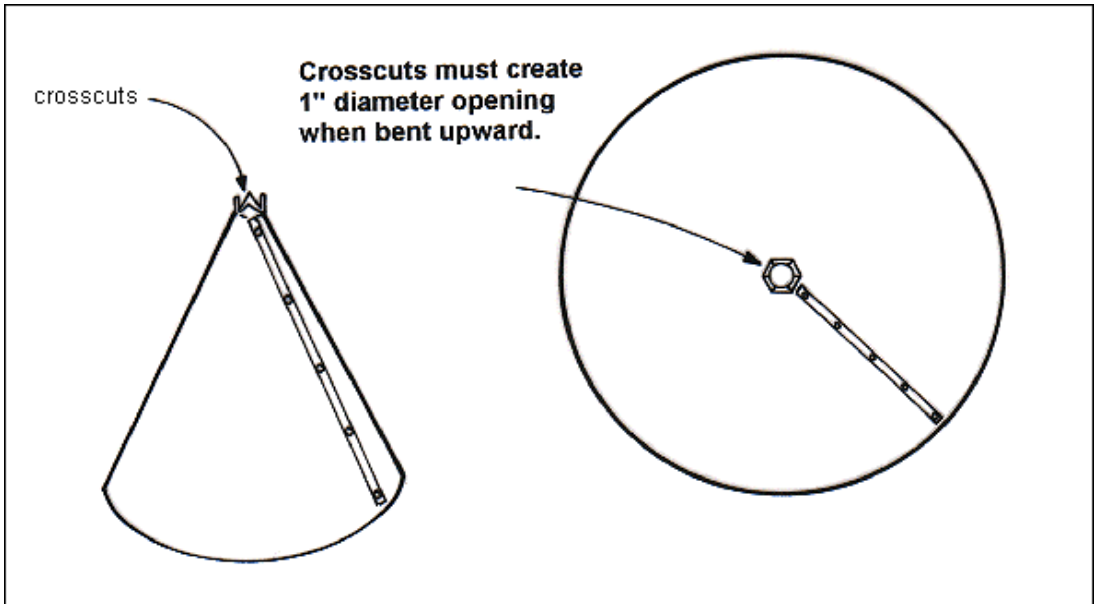

Figure 8.10 Making crosscuts at the apex of the cone.

Assemble the top disc elements following the illustrated steps in Figure 8.11.

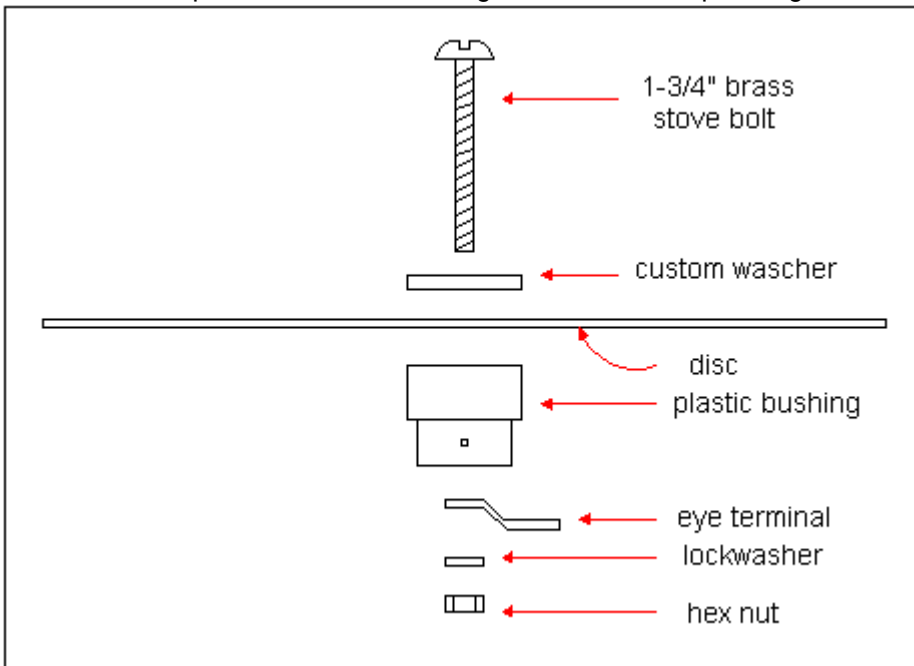

Figure 8.11 Assembling the top disc hardware.

Cut a 30 inches long RG-58/U coaxial cable and solder the inner conductor at one of its ends into the eye terminal held by the bolt below the plastic spacer. Attach a vinyl insulated eye terminal into its braid (see Figure 8.12).

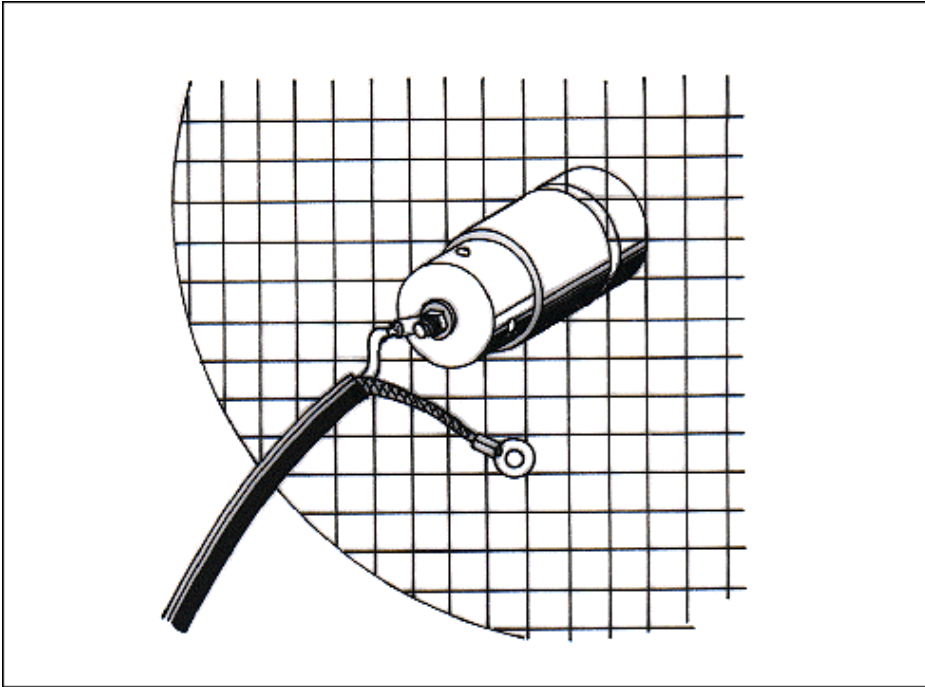

Figure 8.12 Connecting the coaxial cable to the top disc element.

Insert the free end of the coaxial cable into the mounting tube starting from the tube's end with sideholes (see Figure 8.13).

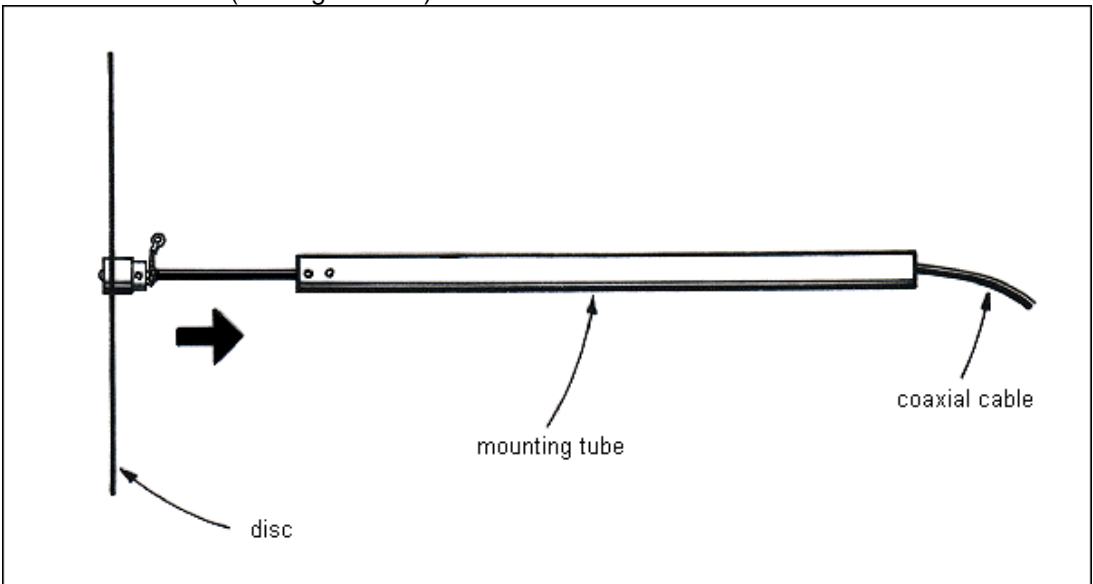

Figure 8.13 Inserting the coaxial cable into the mounting tube.

Insert the plastic spacer/bushing holding the top disc element inside the tube and align its hole to the tube's sideholes. Fix the bushing to the tube permanently using metal screws (see Figure 8.14).

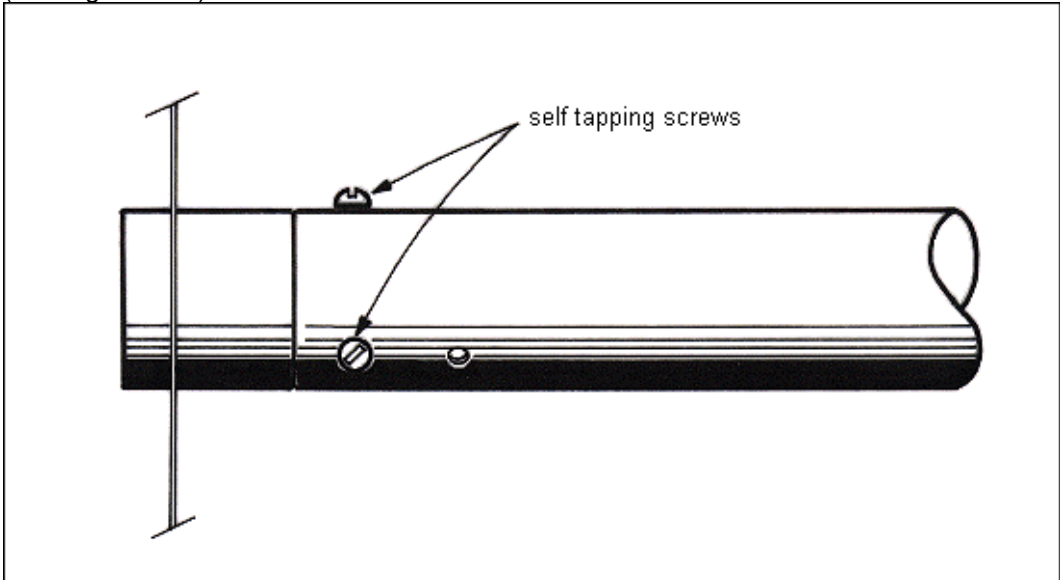

Figure 8.14 Securing the top disc element to the tube.

Align the lower hole to the eye terminal of the braid inside the tube. If it is not aligned yet, insert a slender stick inside the tube and remotely move the eye terminal until you can see it through the hole outside. Insert a metal screw into the hole and turn it until it catches the eye terminal inside. Tighten the screw to hold the terminal firmly (see Figure 8.15). This procedure is the main reason why you should use an eye terminal with a 1/16" diameter eye.

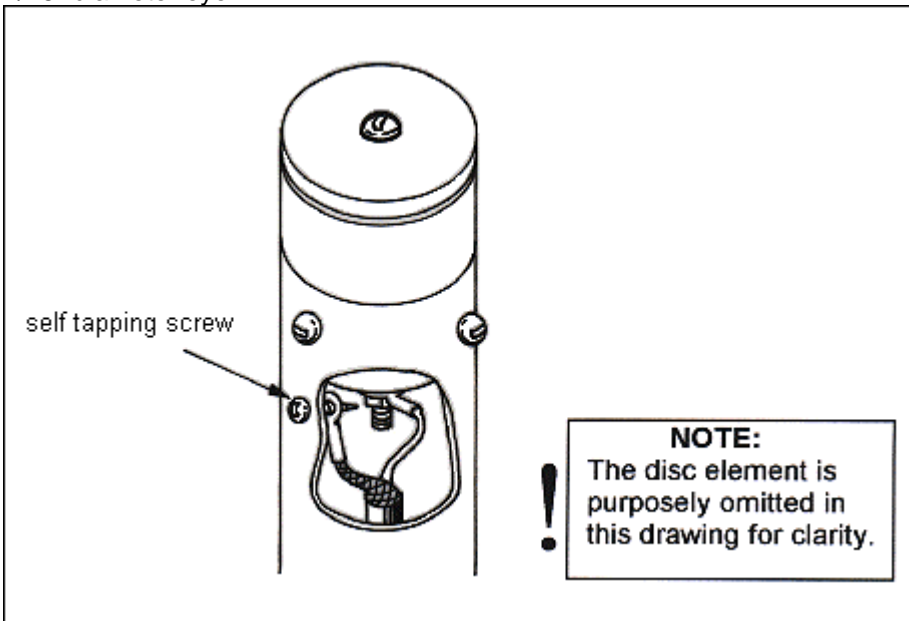

Figure 8.15 Securing the braid inside the mounting tube.

Solder a PL-259 to the free end of the coax cable and connect a straight connector (PL-258) into it prior to the final installation of the antenna (see Figure 8.16).

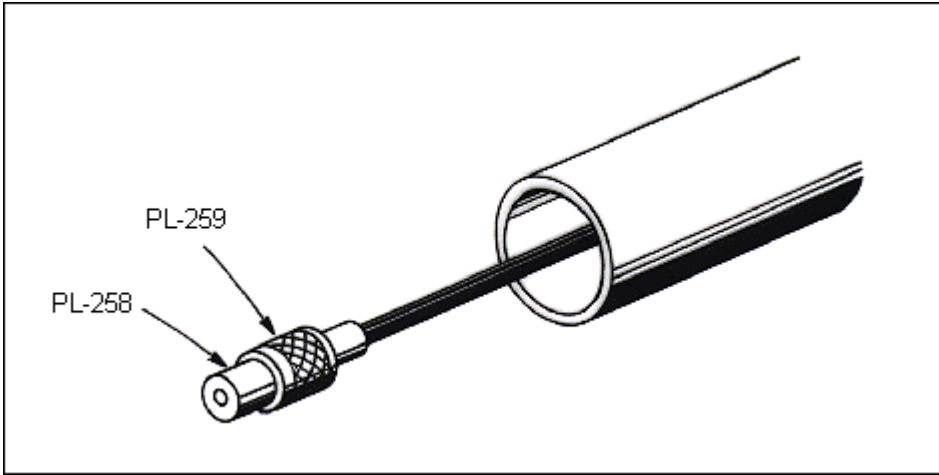

Figure 8.16 Connecting the PL-259 and PL-258 to the coaxial cable.

Finally, insert the PL-259, coaxial cable and the mounting tube into the cone starting from the top until the apex of the cone reaches just a tiny fraction of an inch below the plastic bushing holding the top disc element (see Figure 8.17).

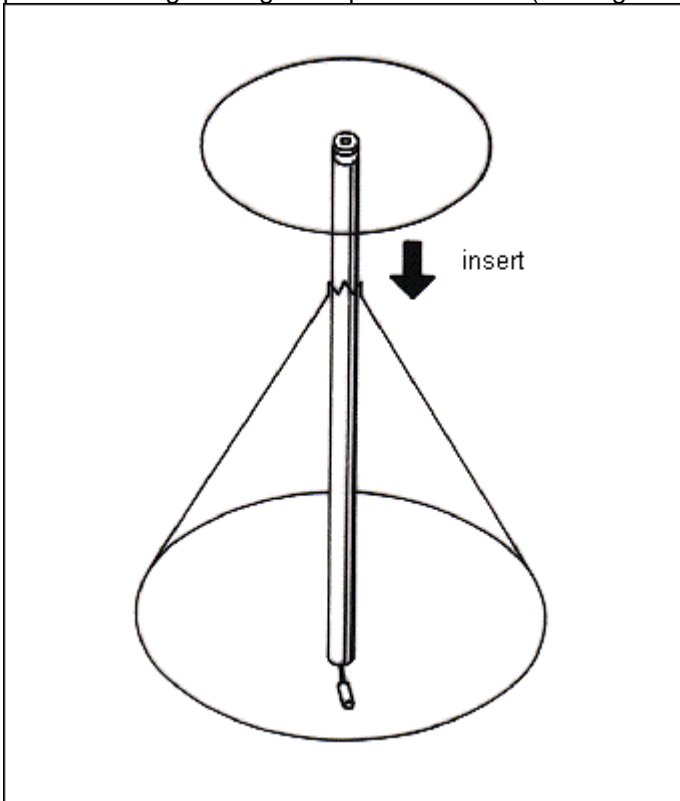

Figure 8.17 Inserting the mounting tube into the cone element.

Attach the stainless clamp around the upturned portion of the wiremesh just under the disc. Tighten the clamp to hold the cone in place. Trim the excess wiremesh protruding above the edge of the tube clamp (see Figure 8.18).

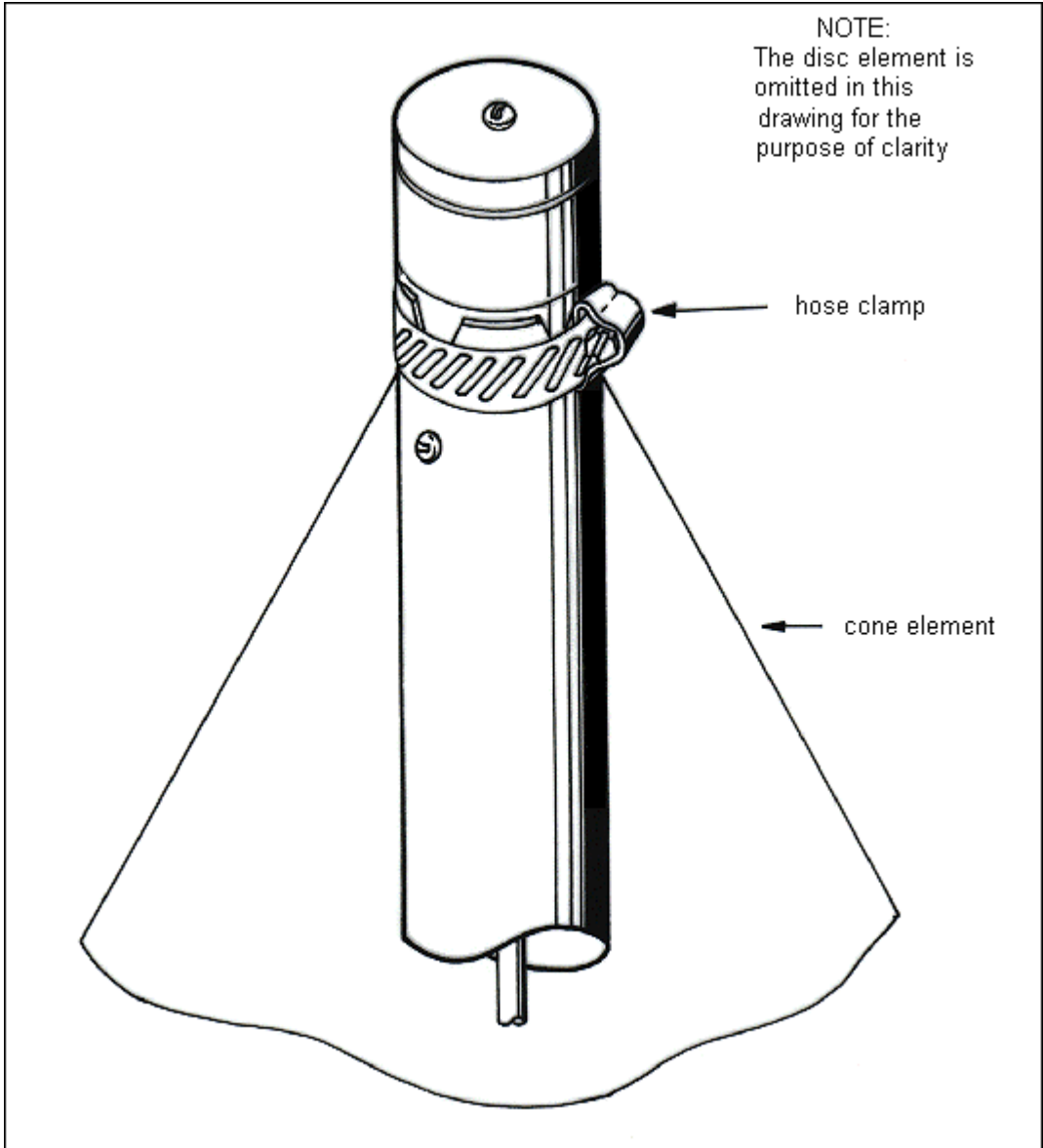

Figure 8.18 Clamping the apex of the cone element to the mounting tube.

Installation of CD-2W

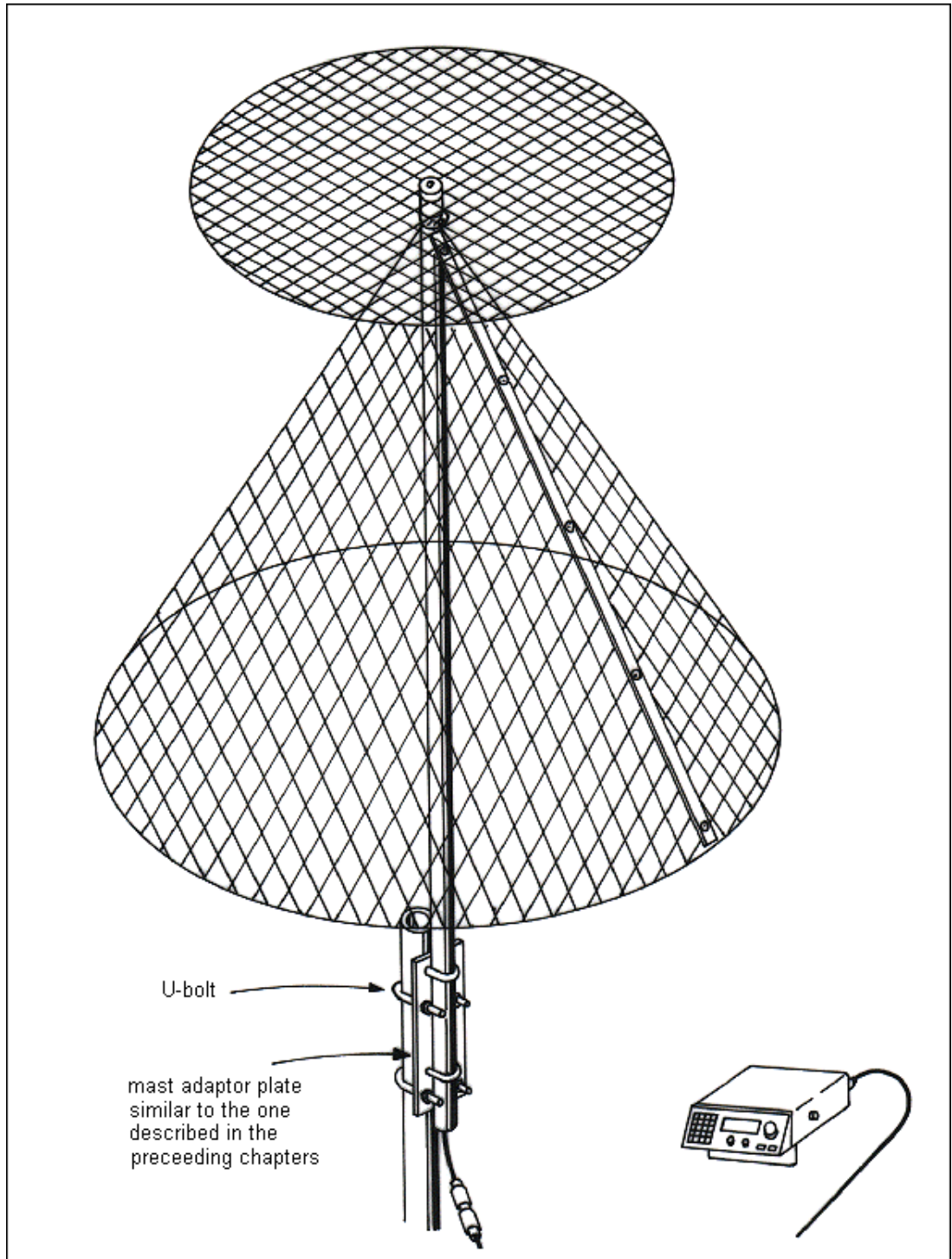

Figure 8.19 Mounting the CD-2W to the mast.

9

DISCONE ANTENNA

Model CD-2P

The discone antenna model CD-2P described in this chapter is functionally similar in most respects to the discone antenna in chapter 8. The only and obvious difference between the two models is the utilization of a metal plate for the disc and cone elements of CD-2P (P for plate).

The choice of using a metal plate becomes evident when the antenna is intended to be installed in areas with less than excellent weather conditions - meaning if your area is regularly visited by heavy rainfall or strong winds, then you must opt to construct and

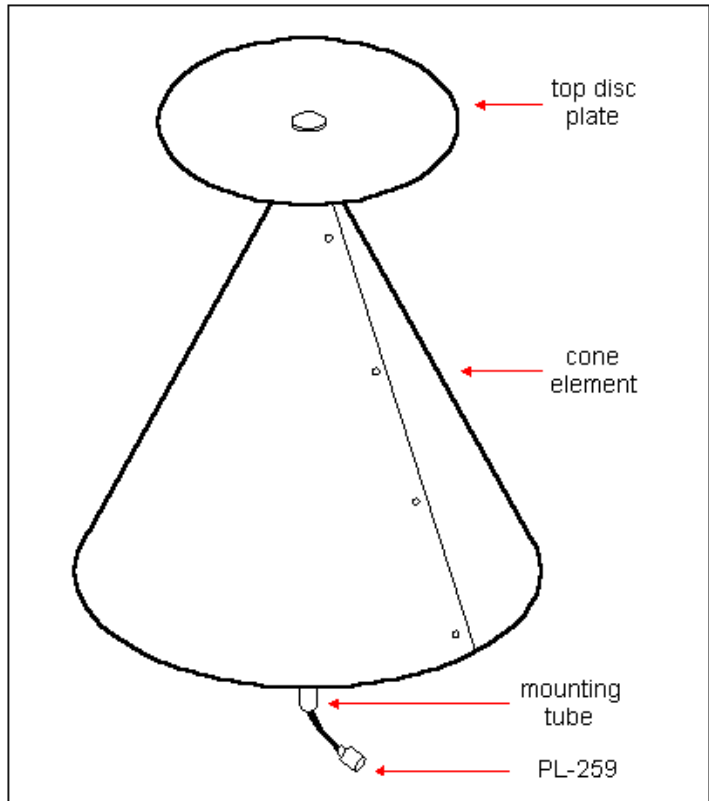

install this more robust model than the wire-screen version. Metal plate is more durable than a wire-screen. The only trade-off is the total cost of the antenna because metal plate is more expensive. In most occasions, a GI metal plate is satisfactory but you can also use a more expensive aluminum plate if you desire so. Aluminum is less susceptible to corrosion so it is highly recommended if you plan to use the antenna near seashores or in places where there is a high level of salt present in the surrounding moisture.

Paint has a negligible effect on the RF signal so if you decide to paint the antenna to make it look attractive, just do it - but don't paint the aluminum mounting tube under the cone element to ensure adequate grounding connection of the antenna to the mast or tower. This is a precautionary measure to avoid a lightning striking your antenna and possibly causing damage to your transceiver or to you.

Materials needed

The materials necessary for the antenna Model CD-2P are the same with those needed for CD-2W except for the wire mesh for the cone and disc which is replaced with a thin metal sheet in CD-2P. Also the two thin metal strips are not needed. However you have to retain the blind rivets for the same purpose.

Construction

In constructing most of the parts of CD-2P, follow the instructions for the Model CD-2W except those for the disc and cone elements. Cut the cone and disc elements out of the thin metal sheet following the dimensions shown in Figures 9.2 and 9.3.

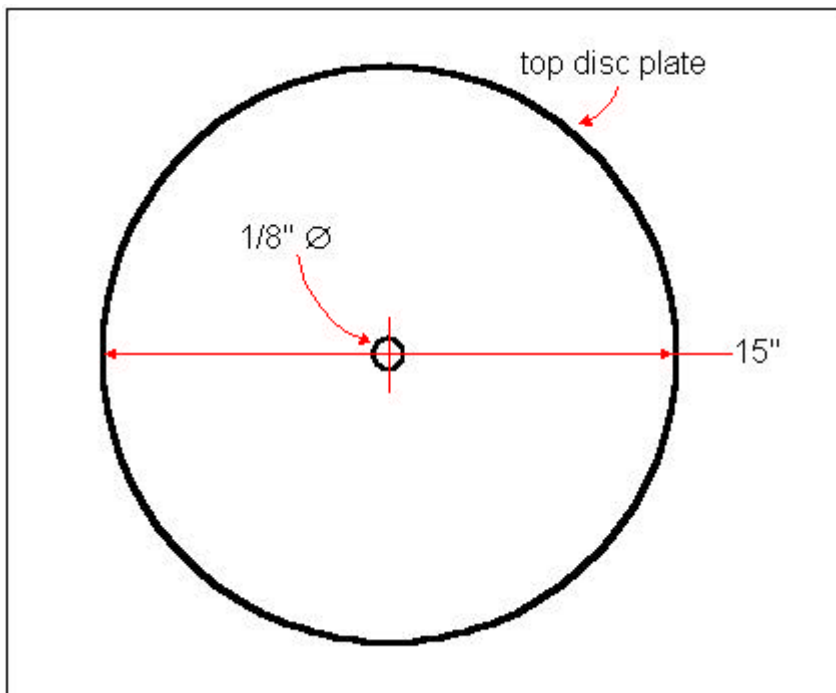

Figure 9.2 Disc element dimension.

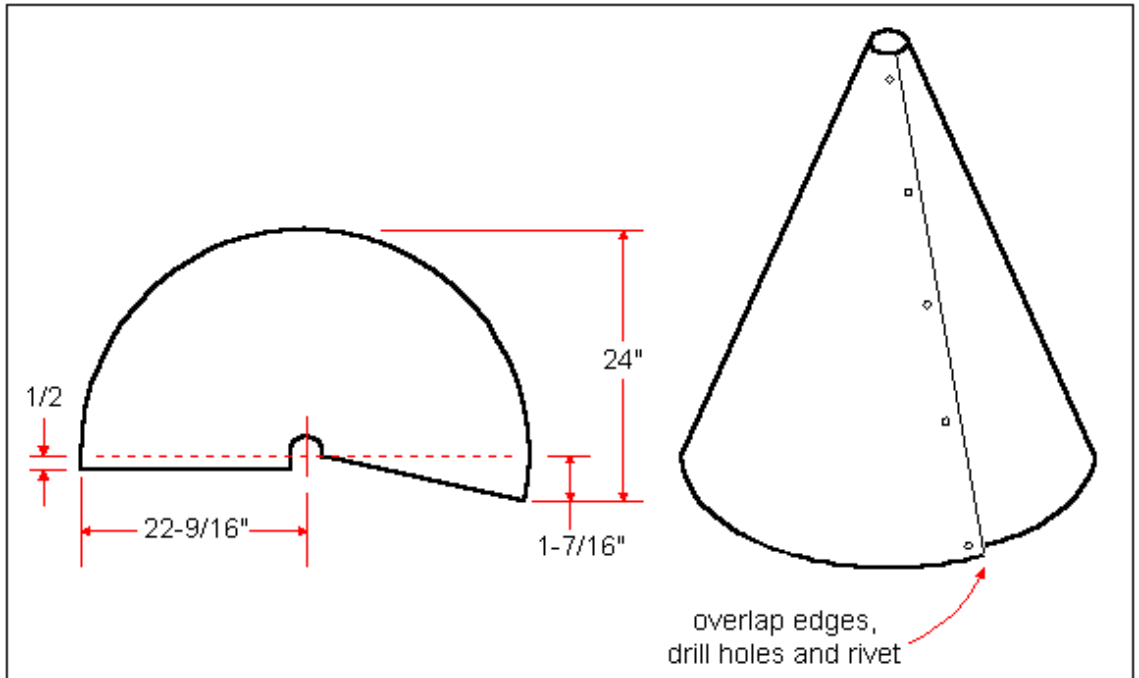

Figure 9.3 Cone plate dimensions.

Unlike the wire mesh cone of CD-2W, the cone for CD-2P must have a metal sleeve soldered to the opening at the apex. Cut a metal sheet and shape it to a form of a ring as shown in Figure 9.4.

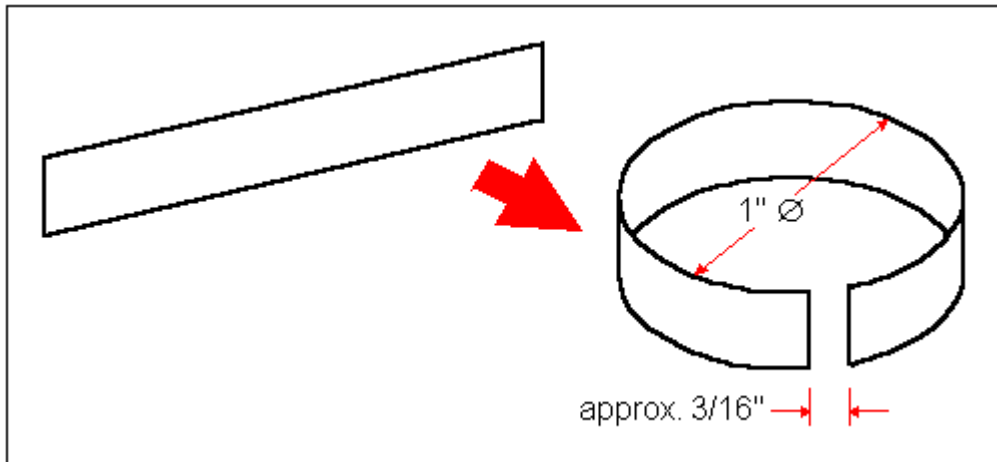

Figure 9.4 Preparing the sleeve.

Solder this sleeve to the rim of the apex opening leaving a small gap between their ends (see Figure 9.5). If you are using an aluminum plate for the cone and sleeve, you need to electrically weld the two pieces together using a special technique for welding aluminum with protective gas.

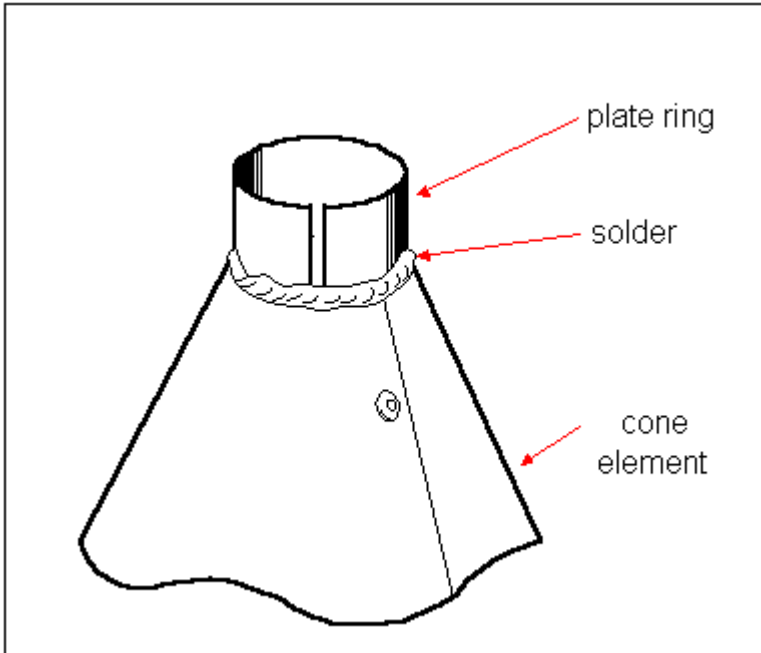

Figure 9.5 Soldering or welding the sleeve to the apex opening of the cone.

The assembly of CD-2P is similar to the steps for assembling the CD-2W (see Figure 9.6).

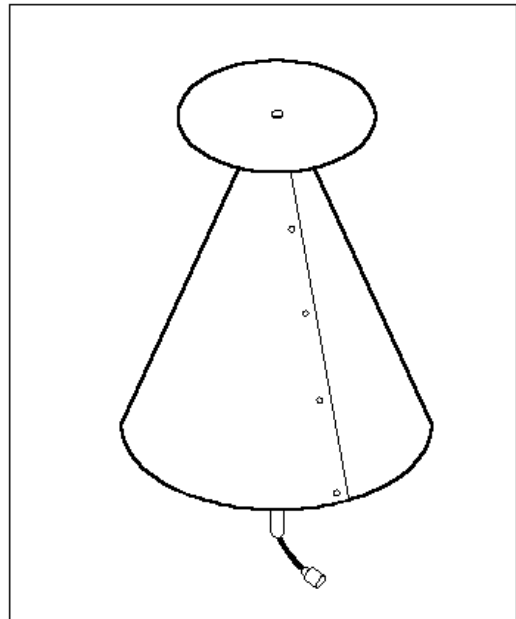

Figure 9.7 Assembled CD-2P.

10 DISCONE ANTENNA

Model CD-2T

In mobile operations the problems related to antenna installation are much greater than those encountered in fixed stations. The problems are worse particularly for a one-man-mobile-station which travels on foot. Those seemingly small items like portable transceiver, spare batteries, coaxial cable, myriad of wires, solar panels, charging box, log books, scanning monitor, etc. could easily total up to more than 20 kilos of deadweight if cramped together inside a single backpack. Add to it the supply of food and few personal belongings and it will surely feel like a nightmare when travelling across a rugged terrain.

The over-all bulk of the load is another problem. Just imagine travelling while lugging a full-size metal plate discone at your back! Because of this, the tendency of mobile operators is to bring only the most important piece of equipment and is usually a portable and lightweight version to trim down the total weight and bulk of the load.

The antenna model described in this chapter is specially designed to satisfy the need for a lightweight and transportable discone antenna. The cone and disc elements are replaced with retractable telescopic rods so that the antenna can be collapsed into a small unit and conveniently stored inside a backpack. The actual length of a packed discone is merely 8 inches! When the telescopic rods are extended to their maximum length and set in the proper angle, they approximate the function of a full disc and cone elements. Theoretically the more elements used the better. Experience showed however that three elements for each disc and cone function are enough on most occasions.

This portable version of a discone antenna has the same electrical characteristics with the two full-sized models described in chapters 8 and 9. The only difference is in the mechanical construction. The chrome plated telescopic rods are quite expensive so the total cost of this antenna is higher than the two preceding models.

If this antenna will be used solely for mobile operations, then the U-bolts intended for mounting may be discarded. Instead, the antenna can be tied with a thin nylon rope on its mounting tube near the feedpoint and hung under a post or branch of a tree. Never use a metallic wire to hang the antenna because it will distort the radiation pattern of the signal or short out the disc and cone elements.

Scaled down appearance

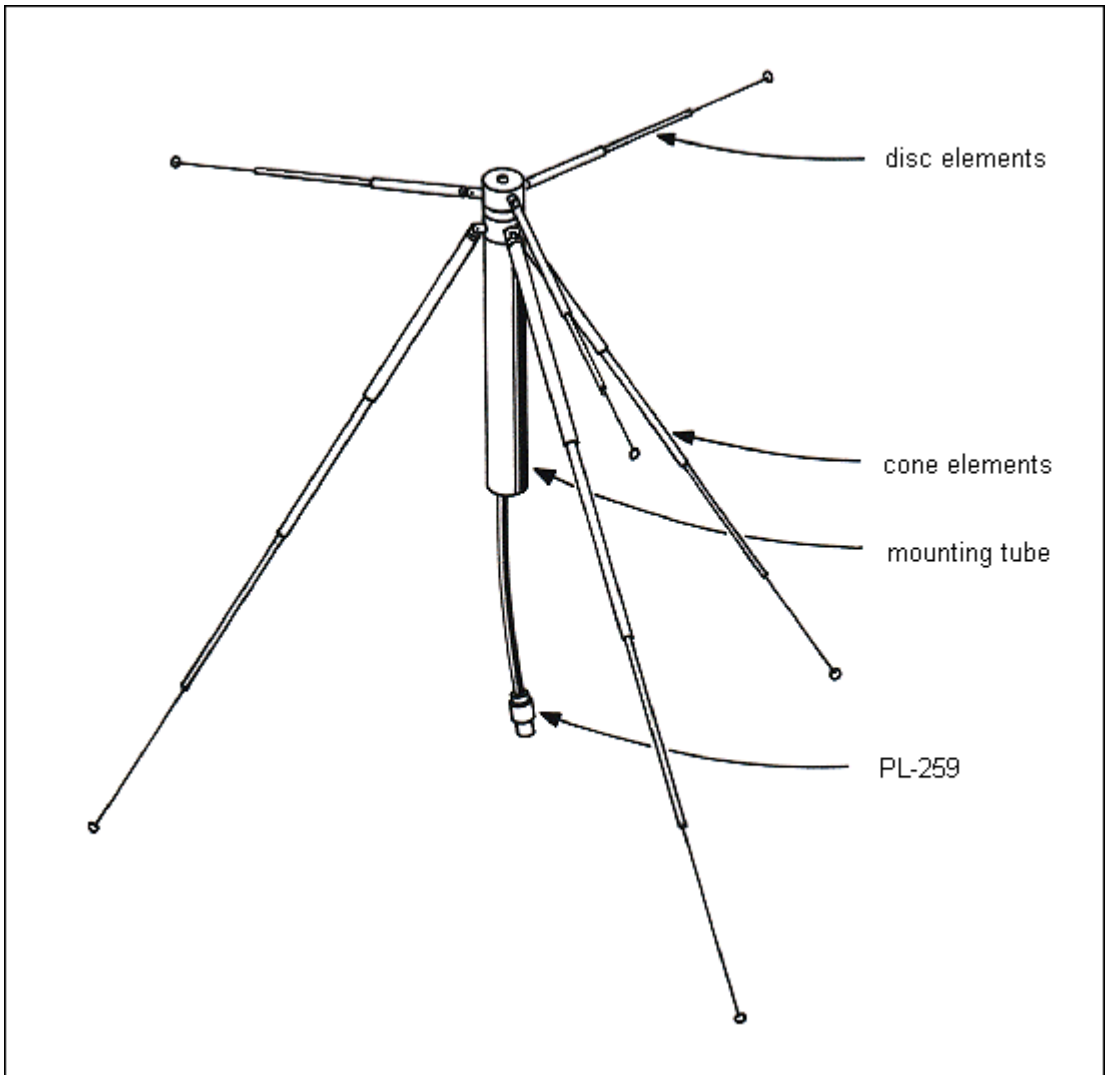

Figure 10.1

Materials List

Quantity	Specification/Description	Dimensions
3	Telescopic antennas - with swivelling threaded base	7" fully extended 3-5" retracted
3	Telescopic antennas - with swivelling threaded base	22" fully extended 5-6" retracted
1	Aluminum disc base mount see text for exact dimensions	
1	Plastic spacer - see text for customized dimensions	
1	Aluminum cone base mount see text for exact dimensions	
1	PL-259 VHF male connector	
1	PL-258 VHF straight connector	
1	Aluminum plate 1/8" thick	3" x 6"
2	Eye terminals - no insulation	
4	U-bolts with accompanying hex nuts and lockwashers	
1	Stove bolt - brass or GI	1/8" x 2"
6	Self tapping metal screws	1/8" x 3/8"
1	Self tapping metal screw	1/8" x 3/4"
1	Hex nut - brass or GI	1/8" id*

*id- inside diameter

Construction

First, prepare the top disc elements base mount by machining an aluminum rod to the necessary dimensions. Follow the dimensions shown in the illustration (Figure 10.2). The size of the holes (holes marked with **a**) and their thread gauge must conform to the dimensions of the short telescopic antenna you intend to use.

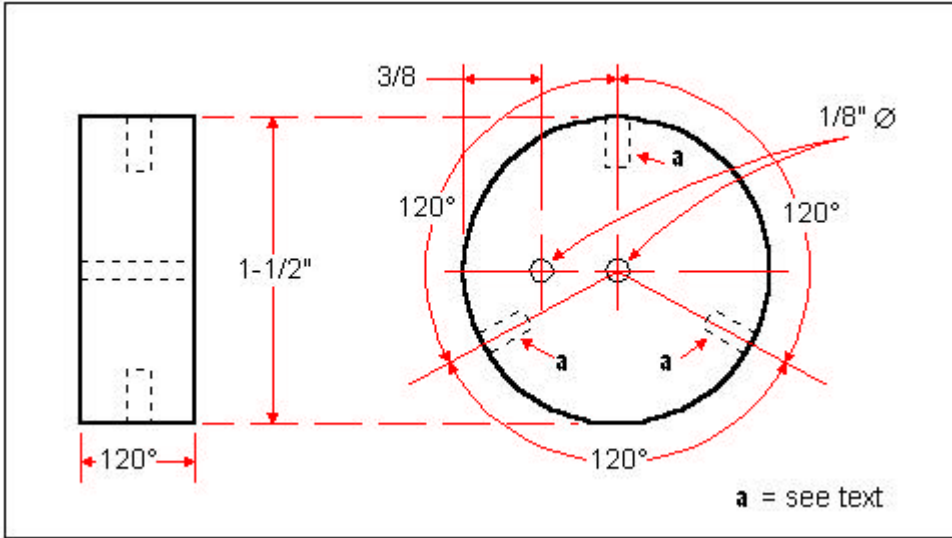

Figure 10.2 Disc base mount dimensions.

Second, prepare the plastic spacer/bushing from a piece of an engineering plastic. Machine it to the form and dimensions shown in Figure 10.3. This plastic spacer insulates the disc base mount from the cone base mount.

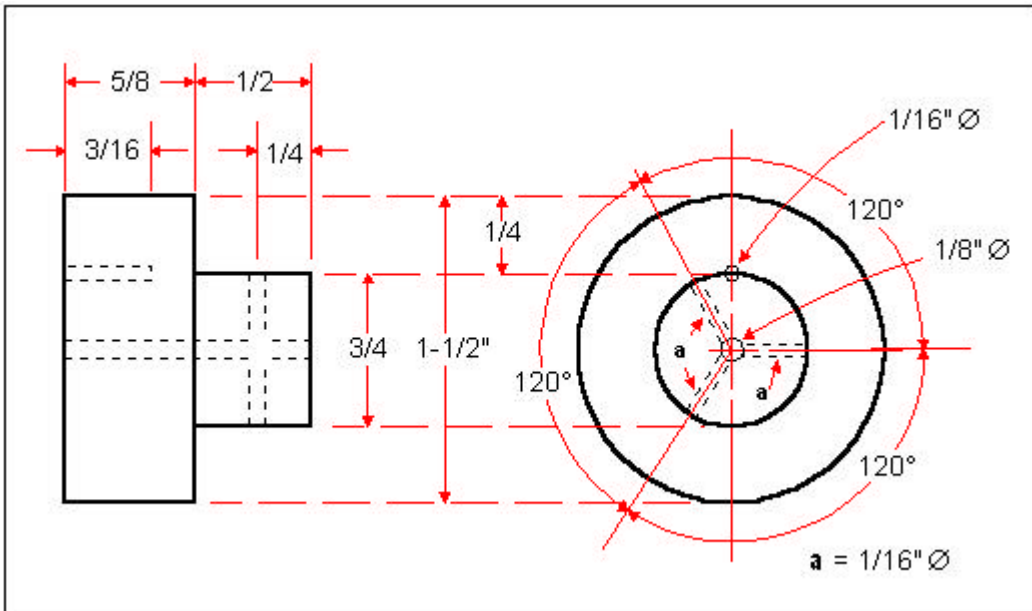

Figure 10.3 Plastic spacer dimensions.

Next step is to prepare the cone elements base mount from an aluminum rod with the necessary size. Machine it to the form and dimensions shown in the following illustration (Figure 10.4). The size, thread gauge, and deepness of the holes at the side (holes marked with a) must conform to the base dimensions of the particular type of telescopic antenna intended for the cone elements.

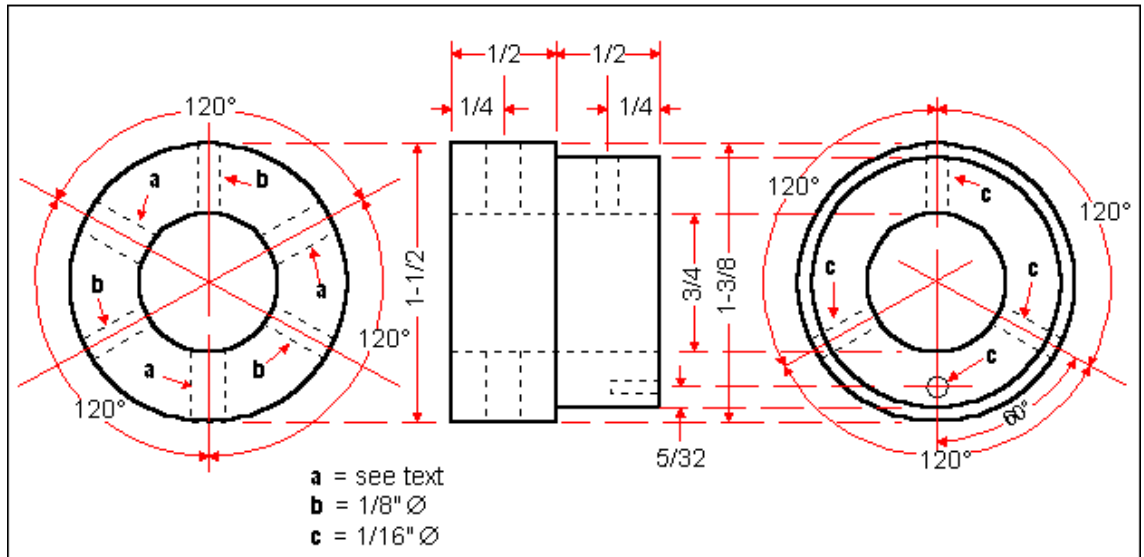

Figure 10.4 Cone elements base mount dimensions.

Assemble the disc base mount, the plastic spacer and the cone base mount together following the arrangement shown in Figure 10.5. Secure the assembly with self tapping screws to the appropriate holes as illustrated.

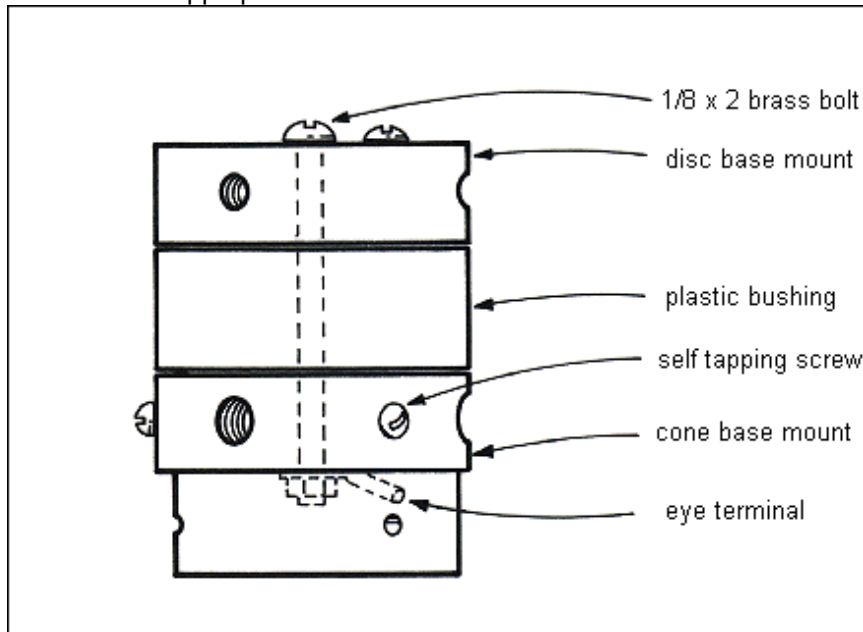

Figure 10.5 Assembly of the elements' base mounts.

Attach the remaining eye terminal to the lone hole at the rim of the cone base mount (see Figure 10.6).

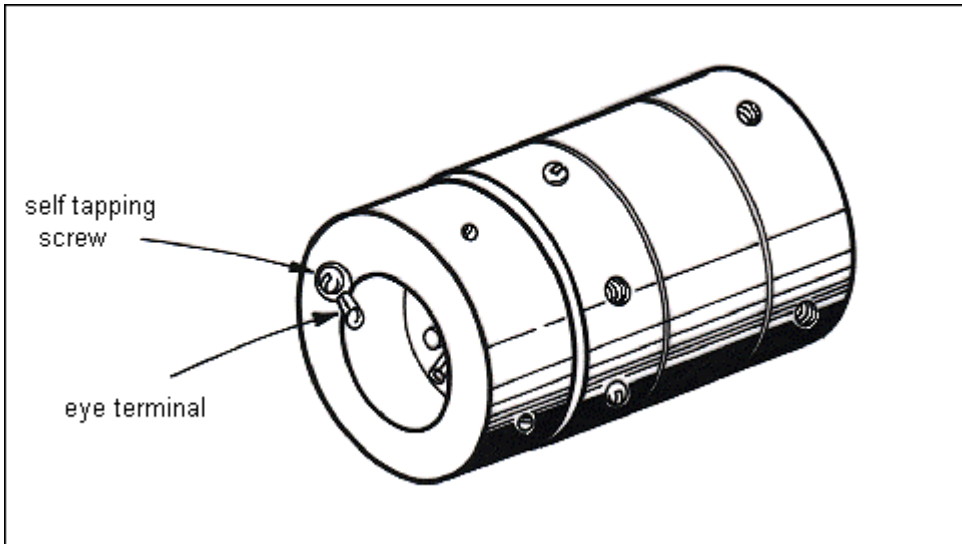

Figure 10.6 Eye terminal attached to the rim of the cone base mount.

Solder one end of the coax cable to the two terminals at the base mount assembly. The inner conductor must be soldered to the center terminal and the braid must be soldered to the eye terminal at the rim (see Figure 10.7). **Never interchange the connection.**

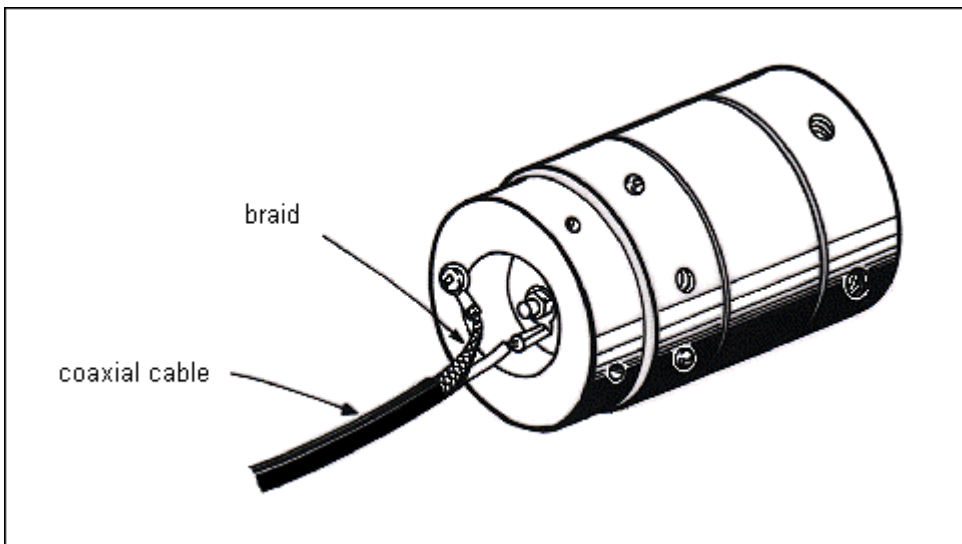

Figure 10.7 Connecting the coaxial cable to the terminals.

Next step is to prepare the aluminum mounting tube by cutting it to a length of 6 inches. Drill three holes ($1/8$ " diameter) at one end (see Figure 10.8). The holes must be equally spaced from each other.

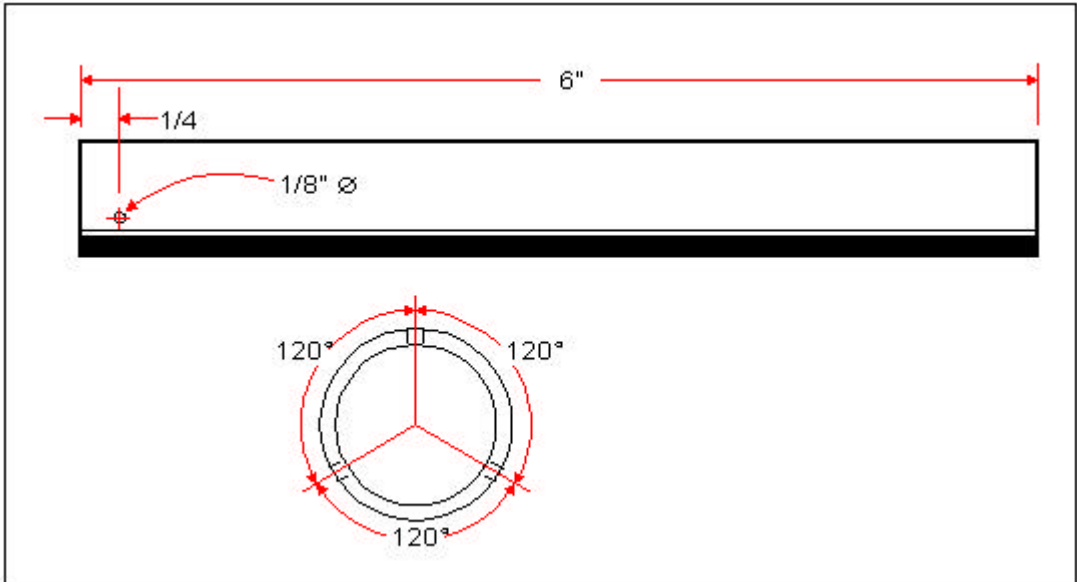

Figure 10.8 Preparing the mounting tube.

Insert the free end of the coax cable inside the aluminum tube starting at the end with sideholes. Insert the aluminum base mount assembly into the tube and align the holes at the sides. Place screws through the holes to permanently attach the base mount assembly into the tube (see Figure 10.9).

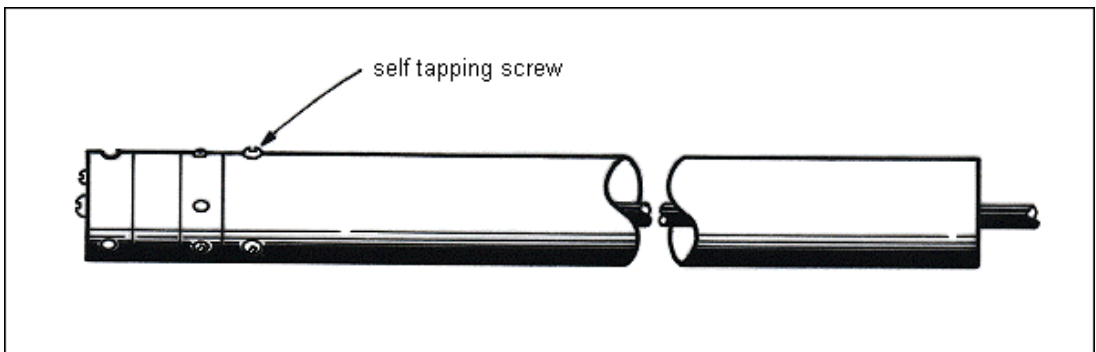

Figure 10.9 Fixing the base mount assembly into the tube.

Solder the PL-259 to the free end of the coaxial cable and attach a straight connector (PL-258) into it (see Figure 10.10).

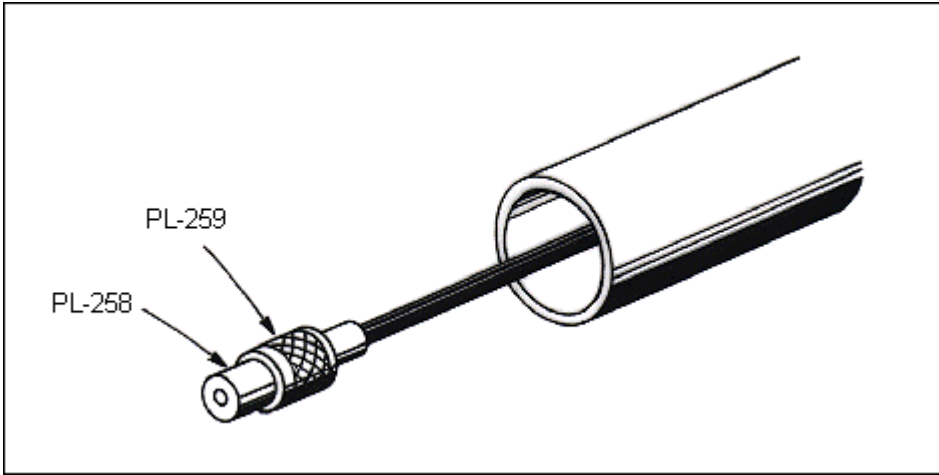

Figure 10.10 Connecting the PL-259 and PL-258.

Attach the three short telescopic antennas into the disc base mount (see Figure 10.11).

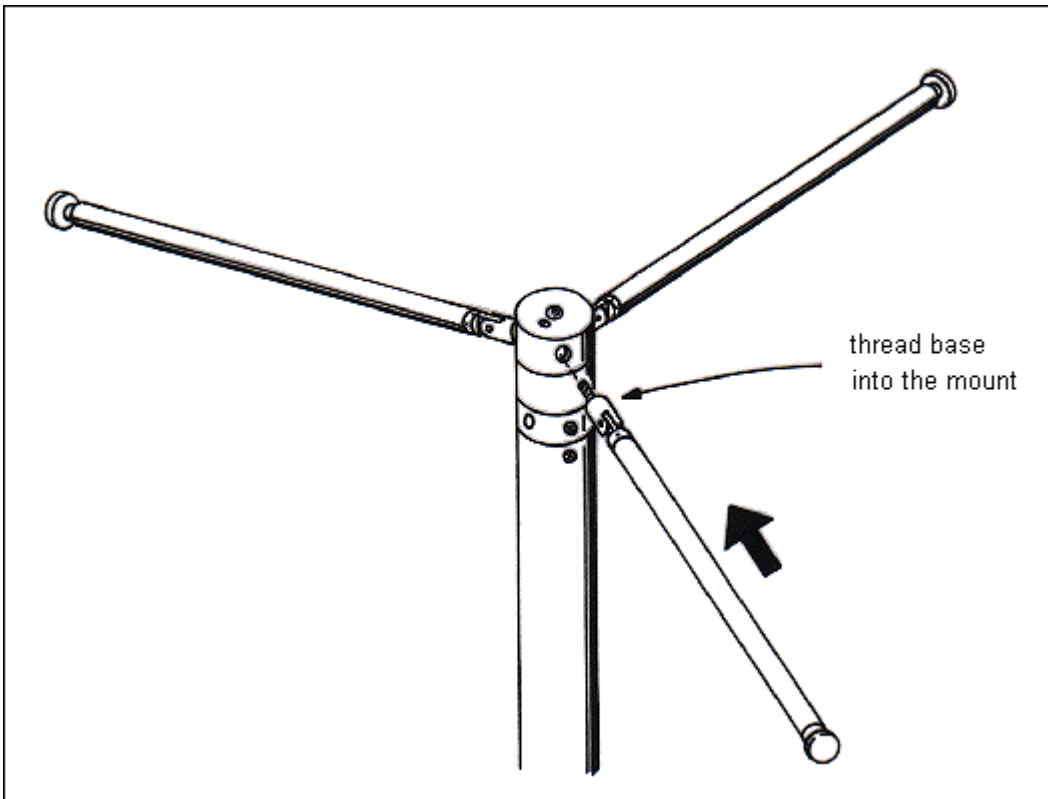

Figure 10.11 Telescopic antennas attached to the disc element mount.

Next, attach the three long telescopic antennas into the cone base mount under the first set of antennas (see Figure 10.12).

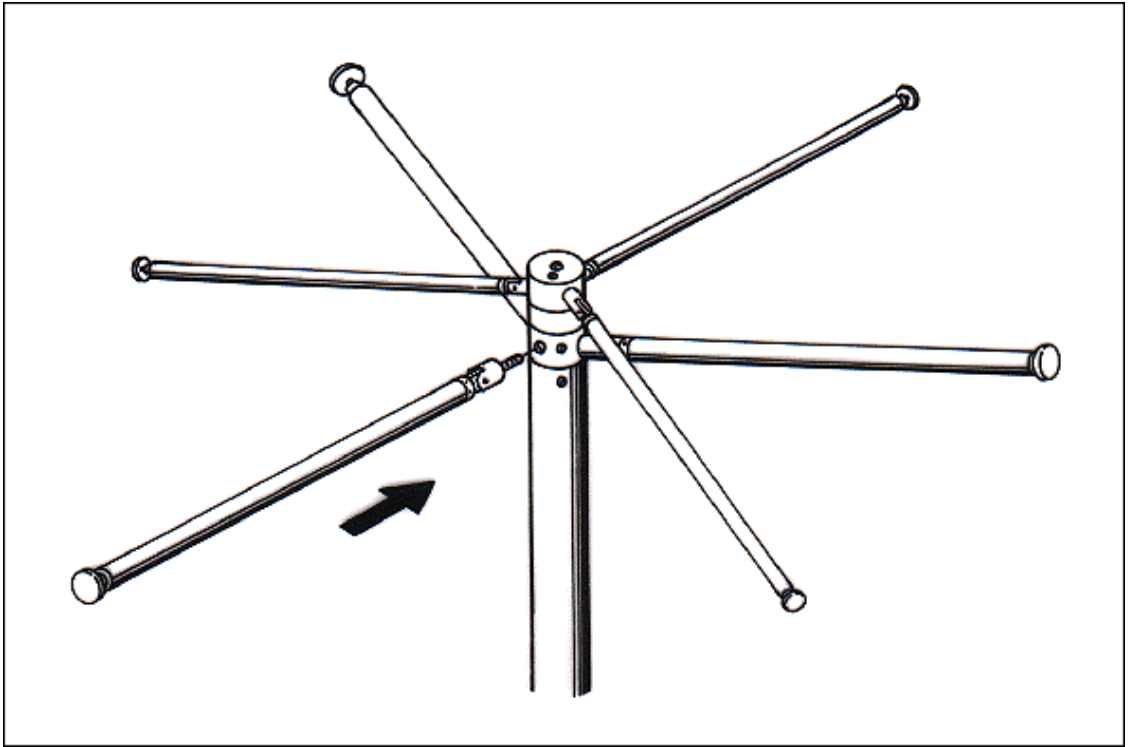

Figure 10.12 Attachment of long antennas to the cone element mount.

Attach the assembled antenna to the mast by using the aluminum mounting plate and one U-bolt. Extend the top telescopic antennas to their full lengths maintaining them in horizontal position. Similarly, extend the three long telescopic antennas to their full lengths but they must be bent to about 60 degrees angle drooping downwards to the ground. See Figure 10.13.



Figure 10.13 Mounting the completed antenna to the mast.

To carry the CD-2T in collapsed form for transportation, retract all the telescopic elements and bend them towards the mounting tube (see Figure 10.14).

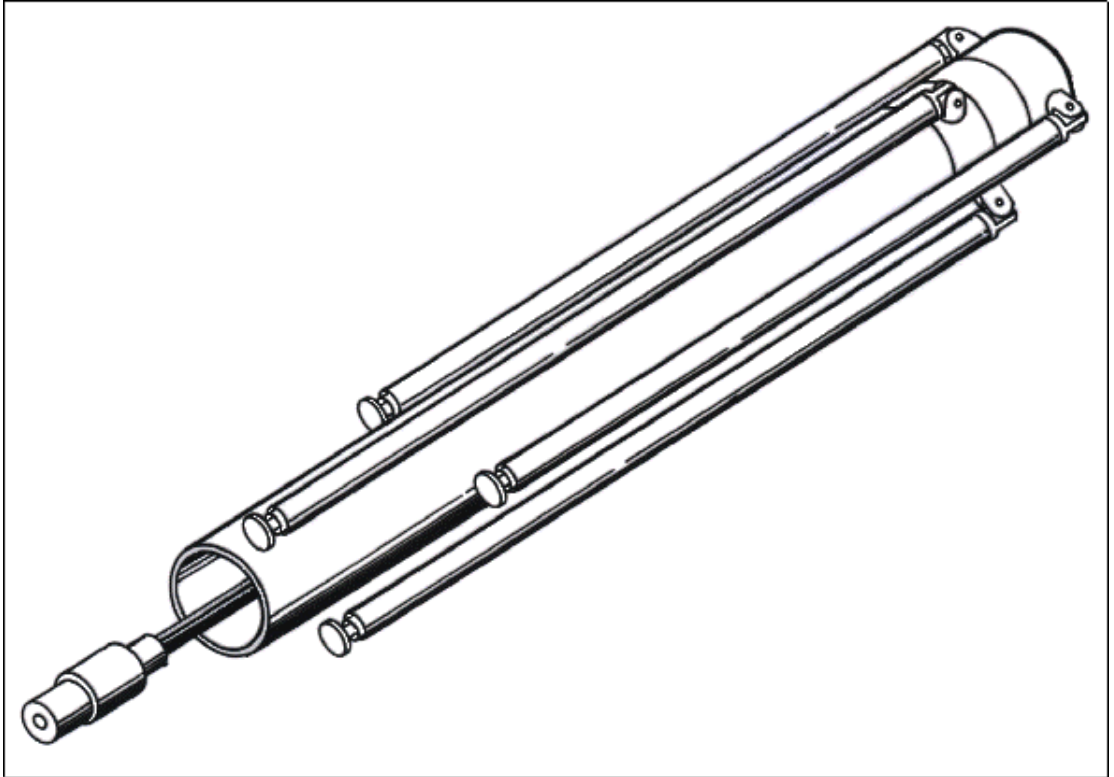

Figure 10.14 Antenna CD-2T in collapsed form.

Model WA-2

Probably one of the most popular vertical antennas for both mobile and fixed station installations is the 5/8 wavelength vertical because it has some gain over a dipole. It is omni-directional and can be used either with radials or a solid-plane body (such as the one afforded by a car).

A version of a 5/8 vertical with radials is presented in this chapter. It is designed for fixed station installations. The common practice of radio operators is to install this antenna atop a tower with rotatable Yagi arrays positioned a few feet below it. The two antennas are connected to a common transceiver via a switching box. Only one antenna is active at one moment. The 5/8 wave vertical is used as a monitoring antenna because of its omni-directional characteristics. Once a contact has been established during operation, the operator quickly switches over to the Yagi antenna and beams it towards the other station to optimize communications. When the contact is finished the transceiver is again switched back to the 5/8 wave vertical antenna. This does not mean however that the average radio operator who cannot afford to erect a tower and a Yagi array should refrain from installing a 5/8 wave vertical. A properly constructed 5/8 wave vertical antenna if used singly works perfectly well!

Perhaps one advantage of constructing this antenna by the radio operator himself is the over-all cost of the unit. All of the materials used in this model are readily available at hardware stores and can be bought cheap. In comparison, a commercial version of this antenna costs more than a thousand pesos!

This antenna model WA-2 is designed to operate in the 140-150 MHz VHF band. It exhibits an SWR of less than 1.5:1 over the entire band if properly tuned. It has a gain of 1.8 dB over a standard dipole reference.

Scaled down appearance:

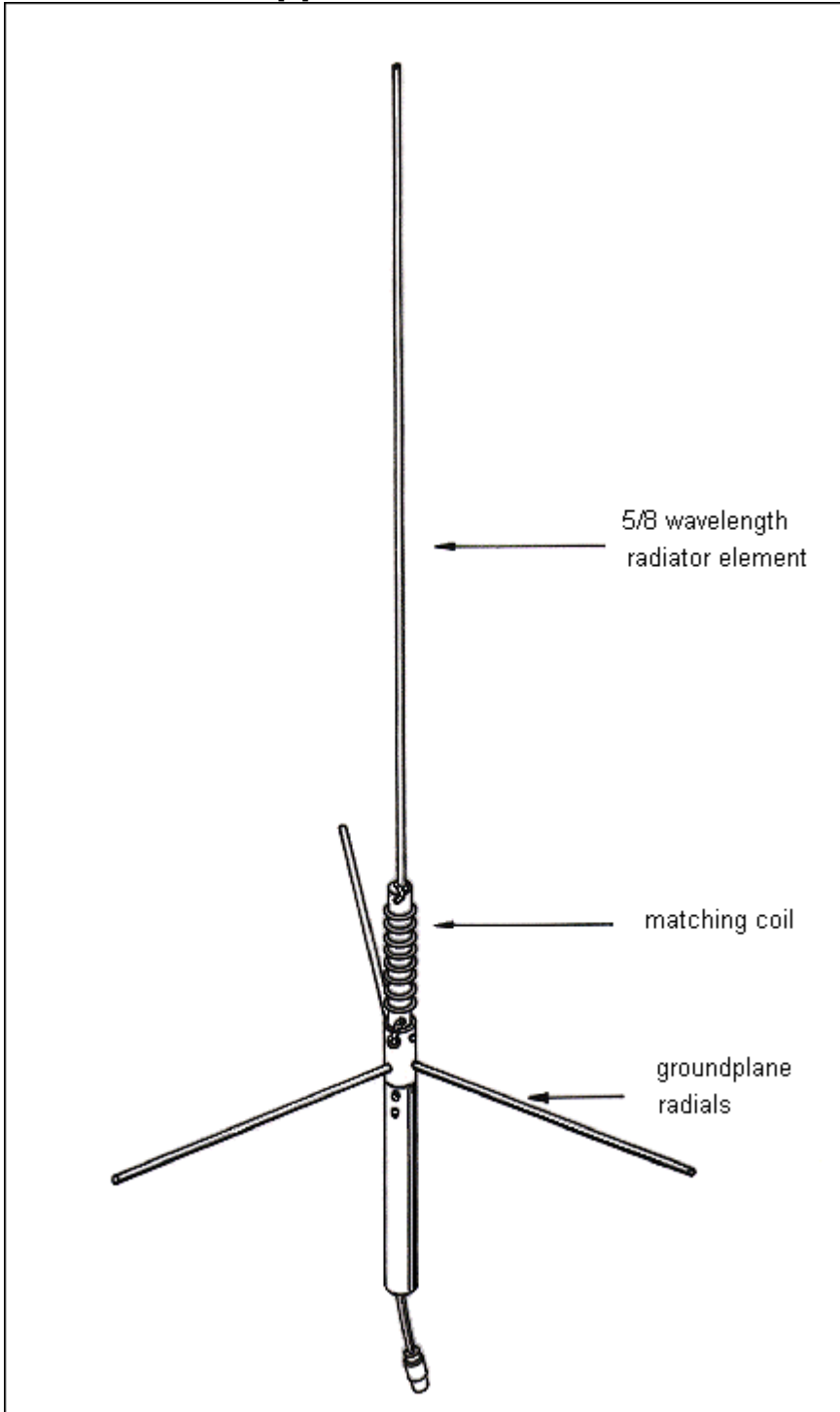

Figure 11.1

Materials List		
Quantity	Specification/Description	Dimensions
2	Brass rods 1/8" diameter the brass rod for acetylene welding is recommended	
3	Brass rods 3/16" diameter	28 " long
1	Engineering plastic rod see text for dimensions	
1	PL-259 VHF connector	
1	PL-258 VHF straight connector	
1	Aluminum bushing - see text for dimensions	
1	Aluminum tube	1" id* x 8"
1	Copper wire gauge no. 14	20" long
1	Aluminum plate 1/8" thick	3" x 6"
4	U-bolts with accompanying hex nuts and lockwashers	
1	Coaxial cable RG-58/U	12" long
1	Stove bolt - brass or GI	1/8" x 3/8"
6	Self tapping metal screws	1/8" x 3/8"
1	Eye terminal vinyl insulated	1/16" id*
1	Short hook-up wire	3"- 4" long

* id - inside diameter

Construction

First prepare the plastic coil form by machining the engineering plastic rod to the dimensions shown in Figure 11.2.

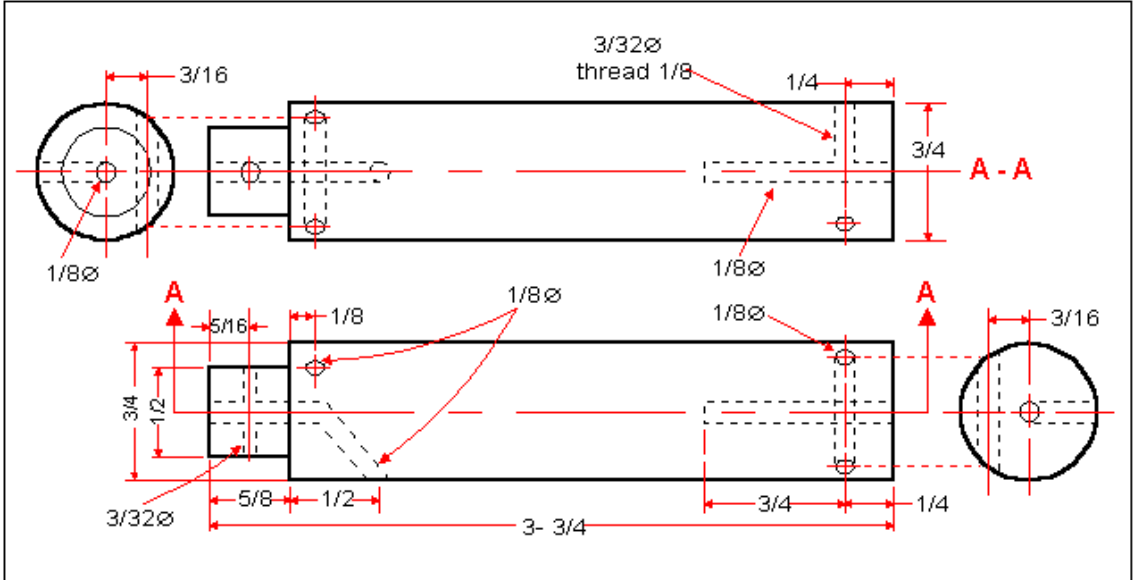

Figure 11.2 Coil form dimensions.

Next, prepare the bushing by machining the aluminum rod to the dimensions shown in Figure 11.3.

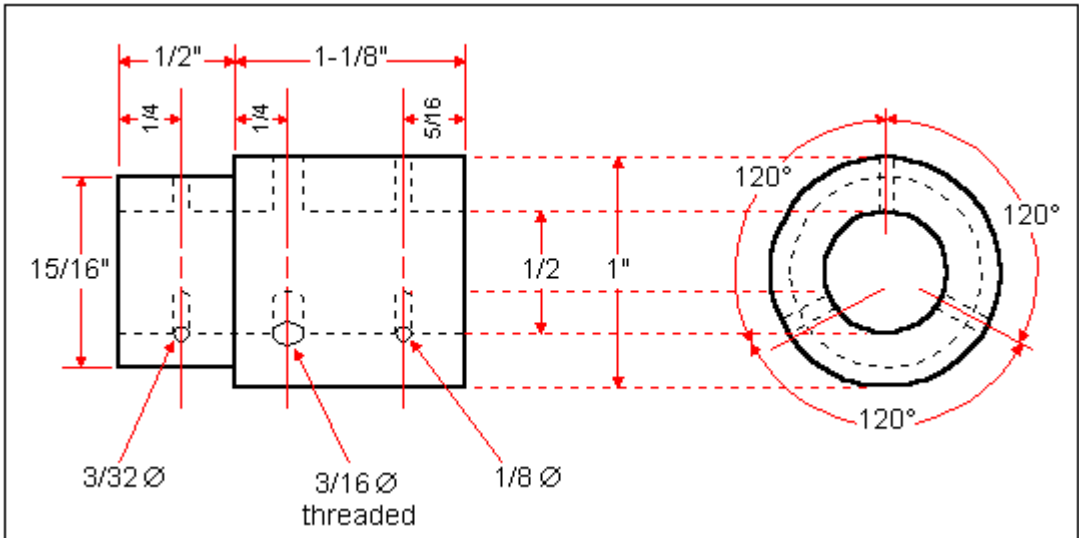

Figure 11.3 Aluminum bushing dimensions.

Assemble the plastic coil form and the aluminum bushing together. Secure the assembly with metal screws. Screw only through the two holes and temporarily leave the third hole unscrewed (see Figure 11.4).

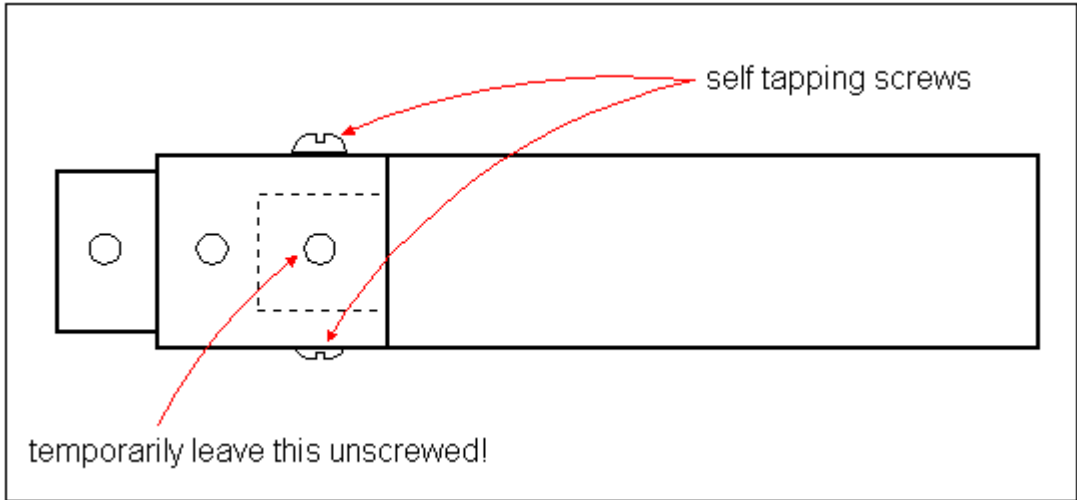

Figure 11.4 Assembling the coil form and the bushing together.

Prepare the radiator element. File a notch at one end of each 1/8" diameter brass rod. Join and solder the two notched ends together to make a long single rod (see Figure 11.5).

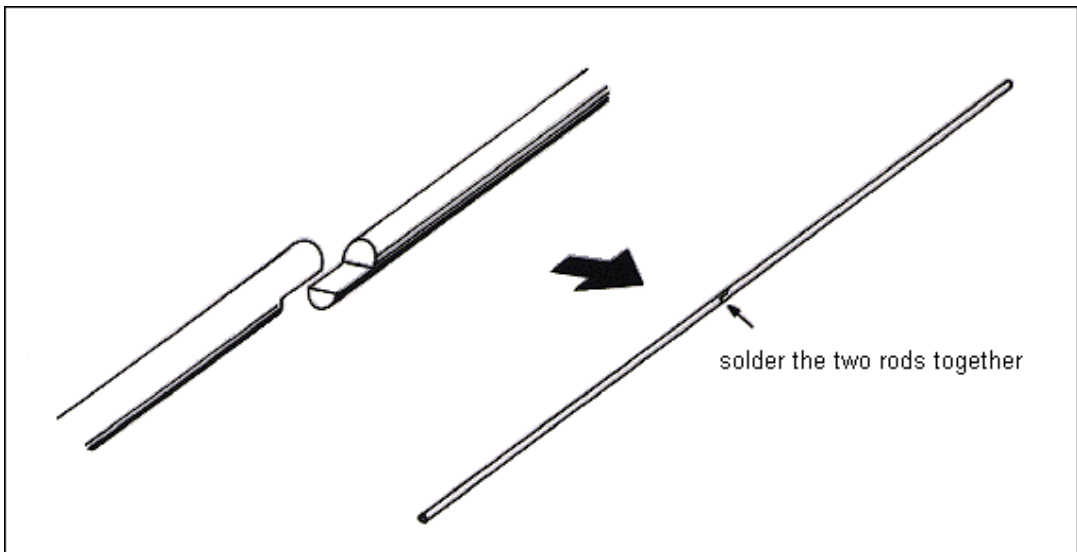

Figure 11.5 Joining the two brass together to make the radiator element.

Insert one end of the radiator rod into the top hole in the plastic coil form. Screw forcibly the 1/8" x 3/8" stove bolt through the hole at the side of the plastic coil form pressing the brass rod inside to hold it firmly (see Figure 11.6).

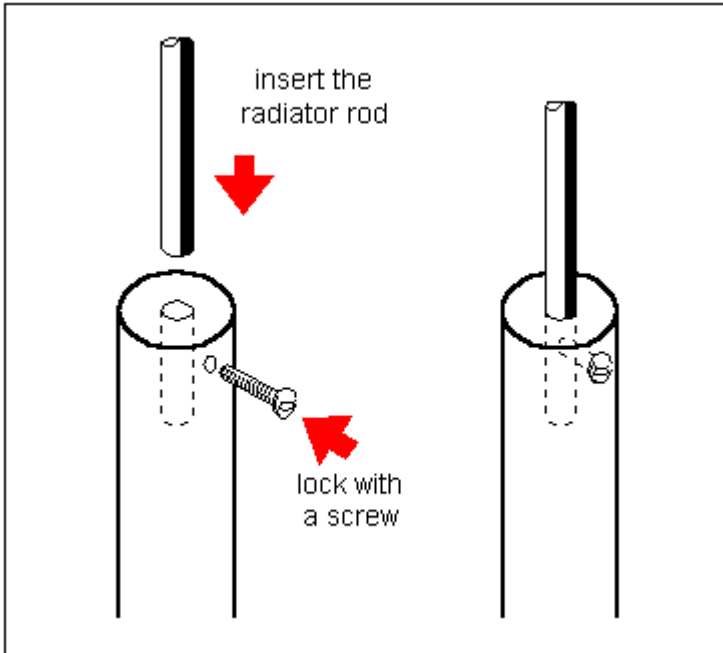

Figure 11.6 Securing the radiator element into the coil form.

Cut the brass rod to a length of 46 inches measuring from the point where it emerges from the plastic form (see Figure 11.7).

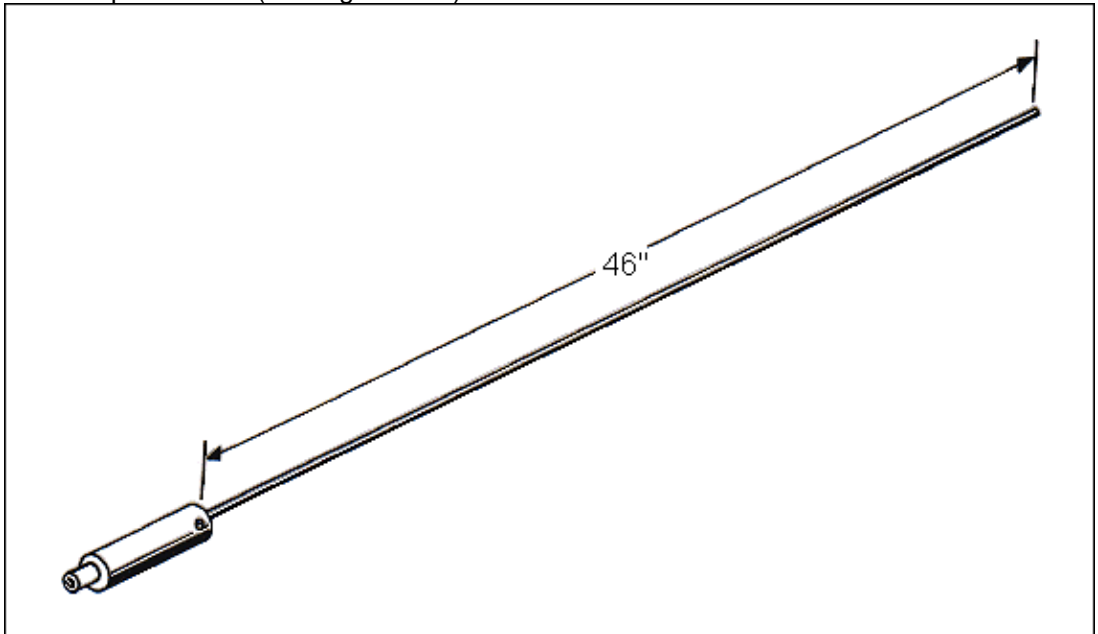

Figure 11.7 Cutting the radiator element to its proper length.

Wind the No. 14 copper wire around the coil form. Wind 10 and 1/2 turns evenly spaced and distributed to cover most of the length of the plastic form. Solder the top end of the copper wire to the base part of the brass rod (see Figure 11.8).

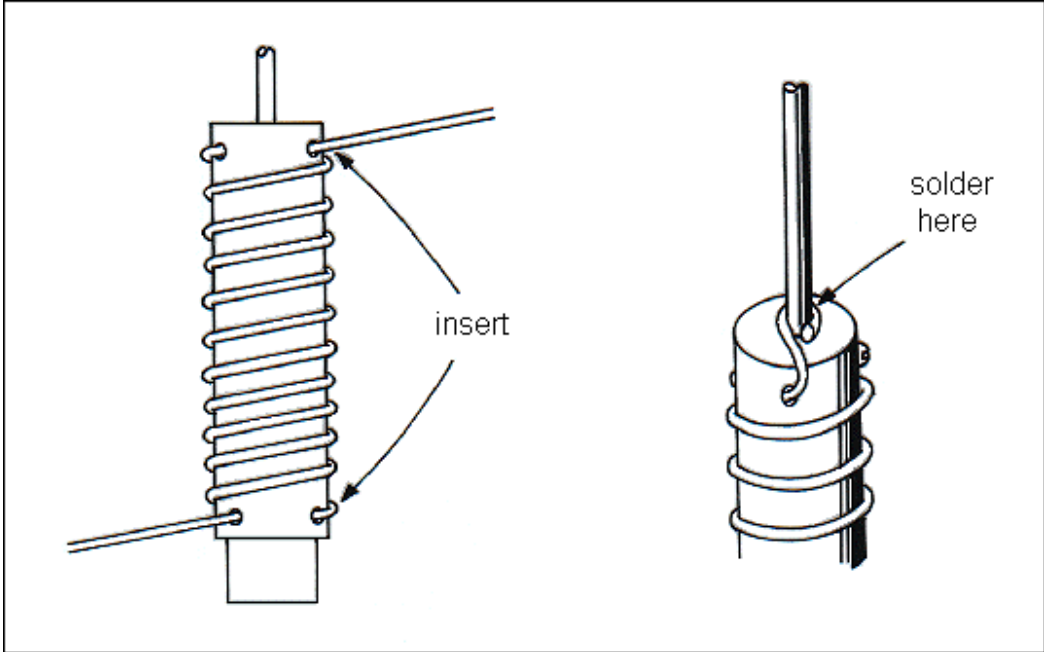

Figure 11.8 Winding the coil around the coil form.

Solder an eye terminal to the lower end of the copper coil. The eye terminal must be positioned in such a way that its eye is aligned with the unscrewed hole in the aluminum bushing. After you have soldered the eye terminal, attach it into the aluminum bushing with a metal screw (see Figure 11.9).

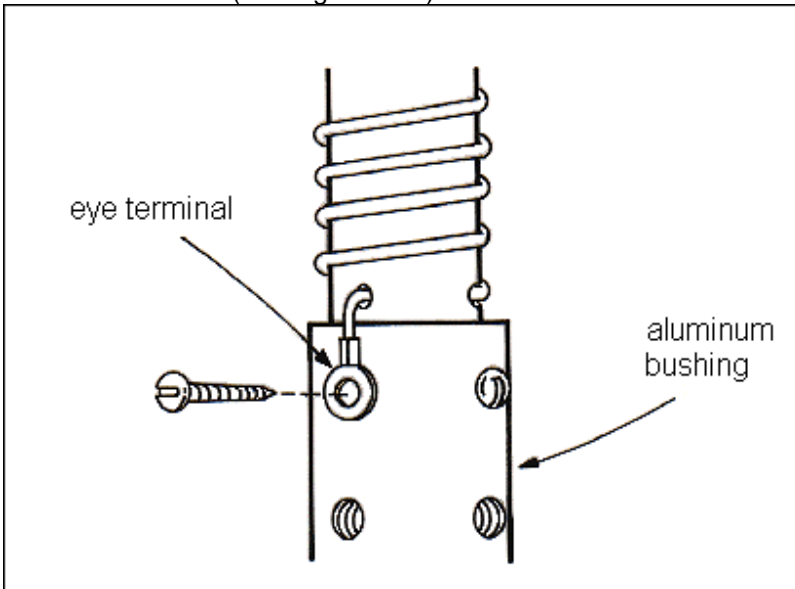

Figure 11.9 Securing the coil to the aluminum bushing.

Cut a short length of stranded hook-up wire (about 3 inches). Insert it into the hole in the plastic coil form until it protrudes from the center hole at the bottom. Solder the upper end of the hook-up wire to approximately 6 and 1/2 turns counting from the coil's lower end connected to the aluminum bushing (see Figure 11.10). This connection is temporary only and it may be necessary to move the wire during tune-up procedure.

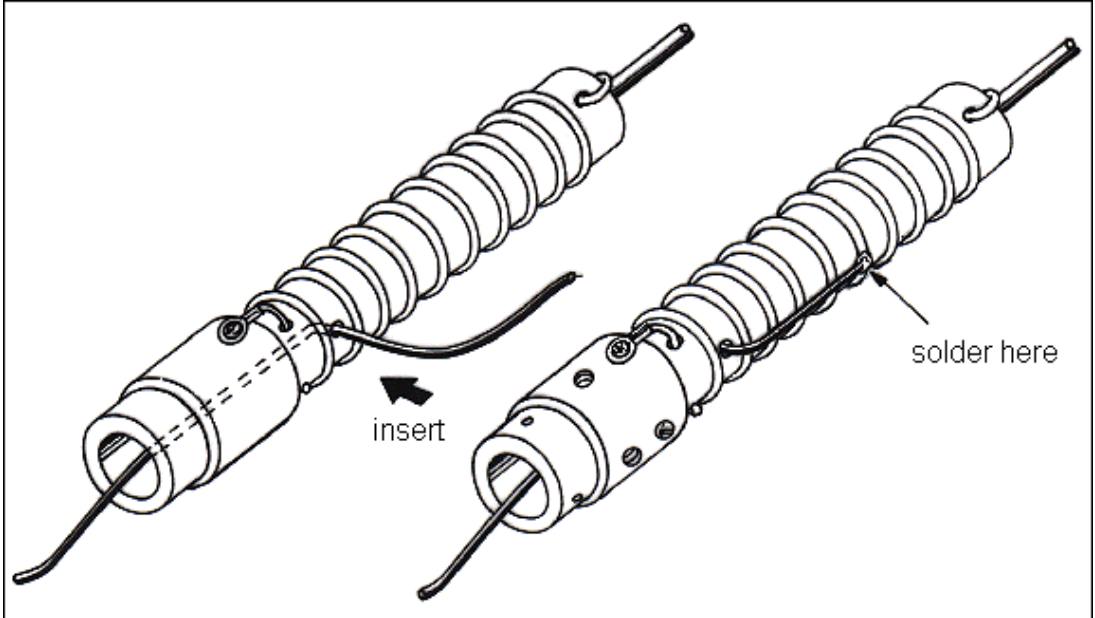

Figure 11.10 Tapping the coil for feedpoint.

Cut 12" length of coaxial cable RG-58/U and separate the braid from the inner conductor at one end (make a pig tail). Solder the inner conductor into the hanging end of the hook-up wire at the bottom of the plastic form. After joining the two wires, insulate the joint either with a shrinking tube or just a plain vinyl tape. Solder an eye terminal into the braid of the coax cable (see Figure 11.11).

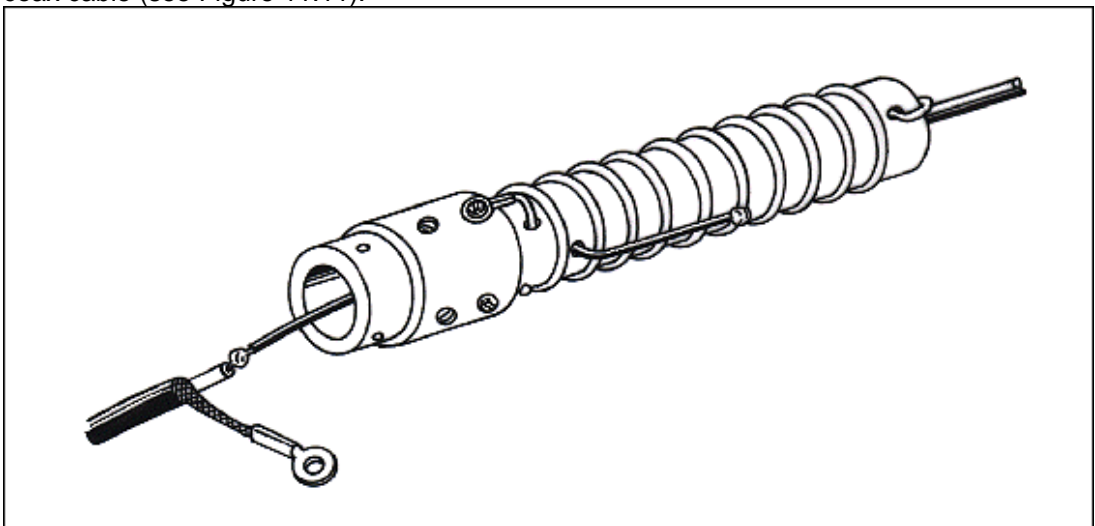

Figure 11.11 Connecting the coaxial cable to the hook-up wire.

Next step is to prepare the mounting tube. Cut 1" diameter tube to a length of 12 inches and drill three holes at one end. The holes must be 1/8" in diameter and equally spaced from each other. Drill a single hole at the same end but slightly below one of the first 3 holes (see Figure 11.12).

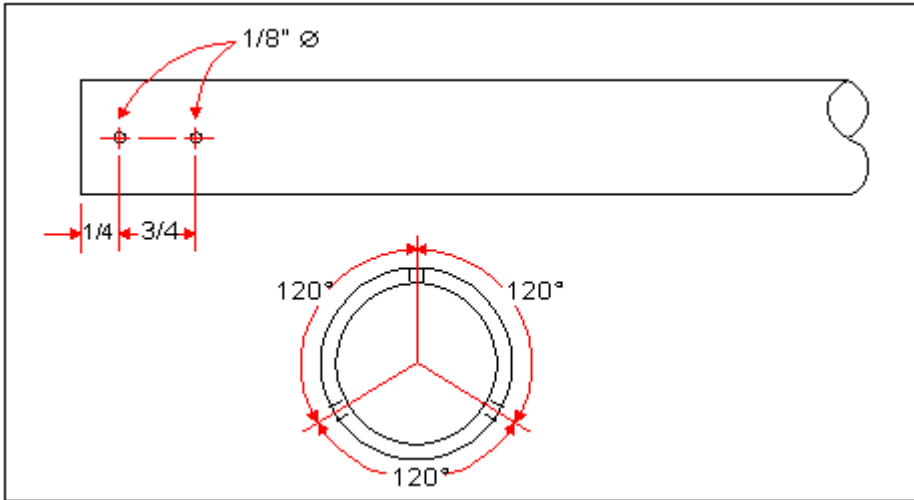

Figure 11.12 Preparing the mounting tube.

Next, insert the free end of the coaxial cable into the mounting tube starting at the end with sideholes. When the aluminum bushing and tube meet, insert the bushing inside the tube and align the holes at their sides. Secure the bushing into the tube by screwing self tapping screws into the holes (see Figure 11.13).

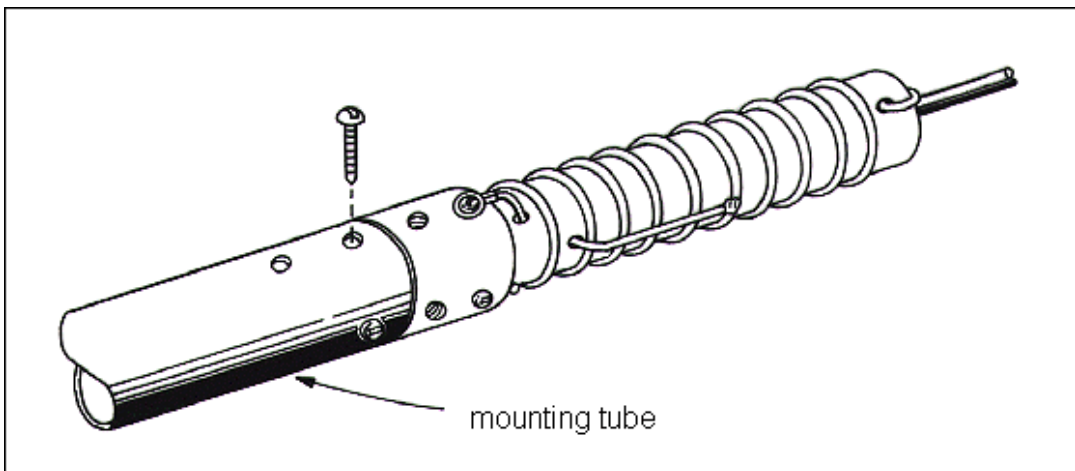

Figure 11.13 Securing the aluminum bushing into the mounting tube.

Secure the braid by inserting a self tapping screw into the lone hole and tapping into its eye terminal inside the tube. Tighten the screw to hold the eye terminal against the wall of the tube (see Figure 11.14). You may need to use a wooden stick inserted into the tube to position the eye terminal exactly under the hole.

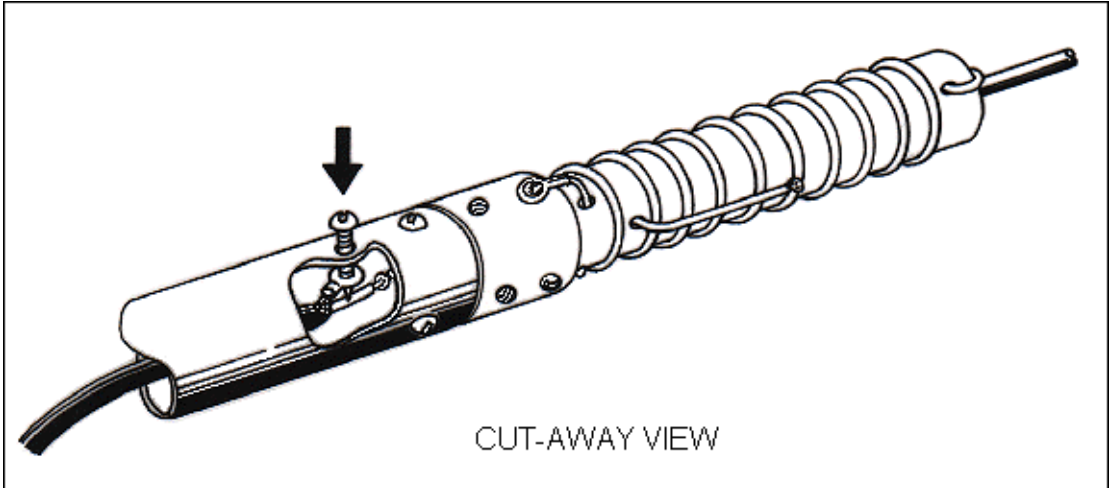

Figure 11.14 Securing the braid inside the tube with a metal screw.

Next, prepare the groundplane radials. Cut three lengths of 3/16" diameter brass rods. Note that these rods are larger than the radiator rod. Each rod must be 28 inches long and threaded at one end (see Figure 11.15).

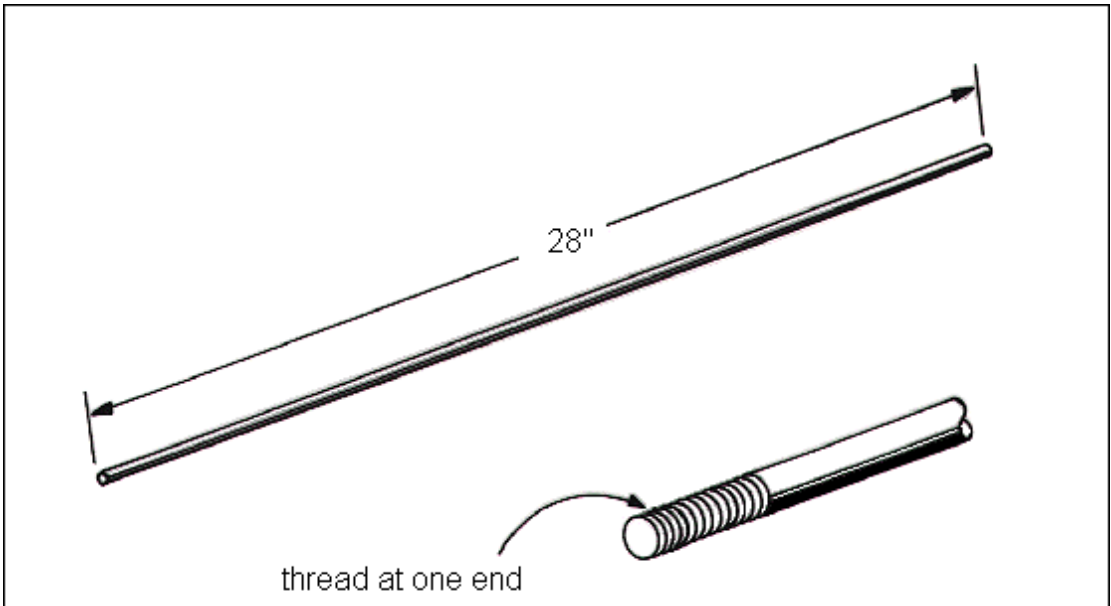

Figure 11.15 Cutting the radials and threading one of their ends.

Final assembly and installation

Attach the three groundplane radials into their mounting holes at the aluminum bushing. Mount the antenna to the mast by using a metal plate adaptor similar to one described in the preceding chapters (see following illustration).

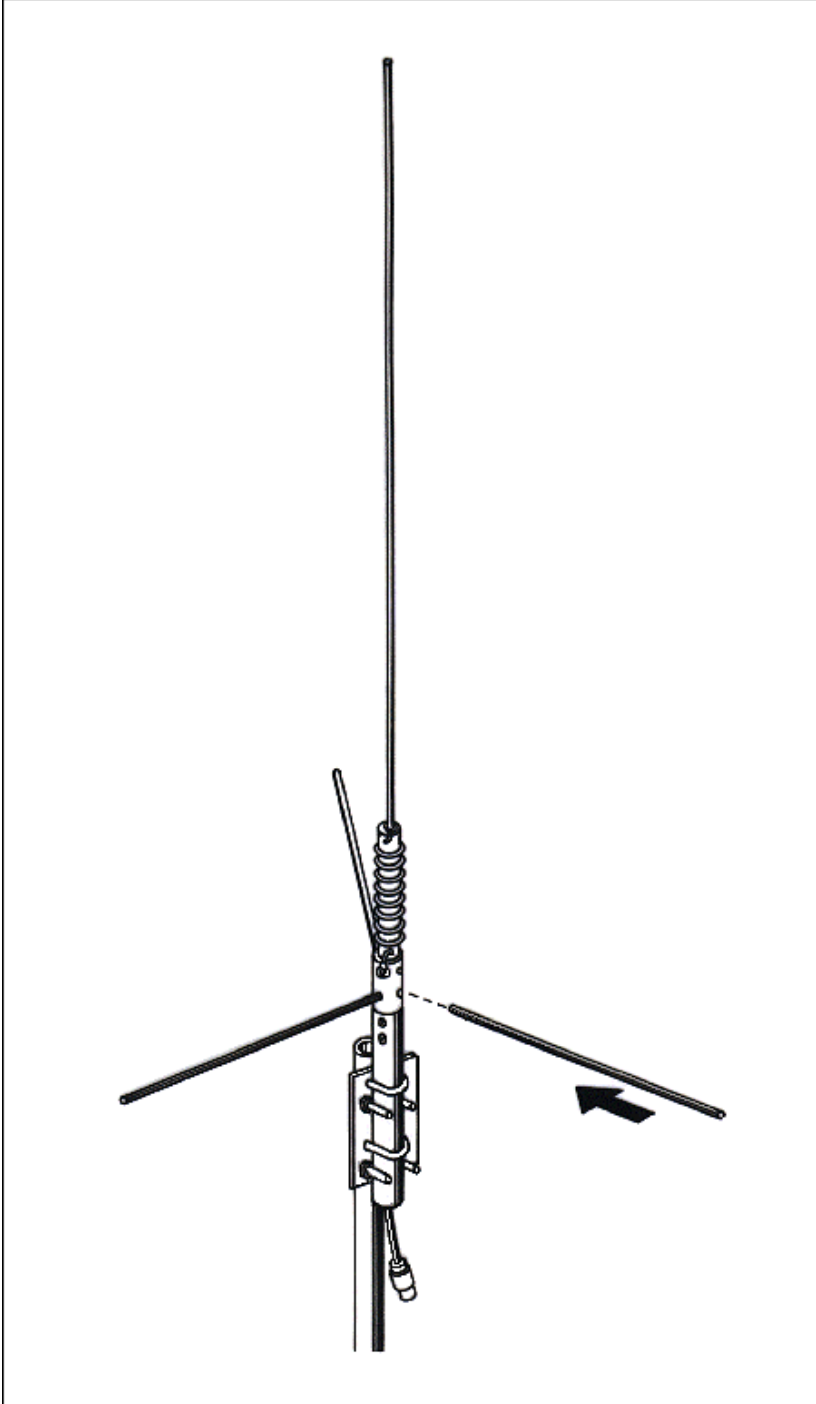

Figure 11.16 Mounting the WA-2 to the mast.

Tuning WA-2 to resonance

Mount the antenna to the mast as previously described. Connect a coaxial cable into the PL-258 connector of the antenna and attach the other end into the output of an SWR meter (marked with 'antenna'). Attach also a short coaxial feeder into the input of the SWR meter (usually marked 'transmitter') and the other end of the feeder must be plugged into the output connector of your transceiver (see Figure 11.17).

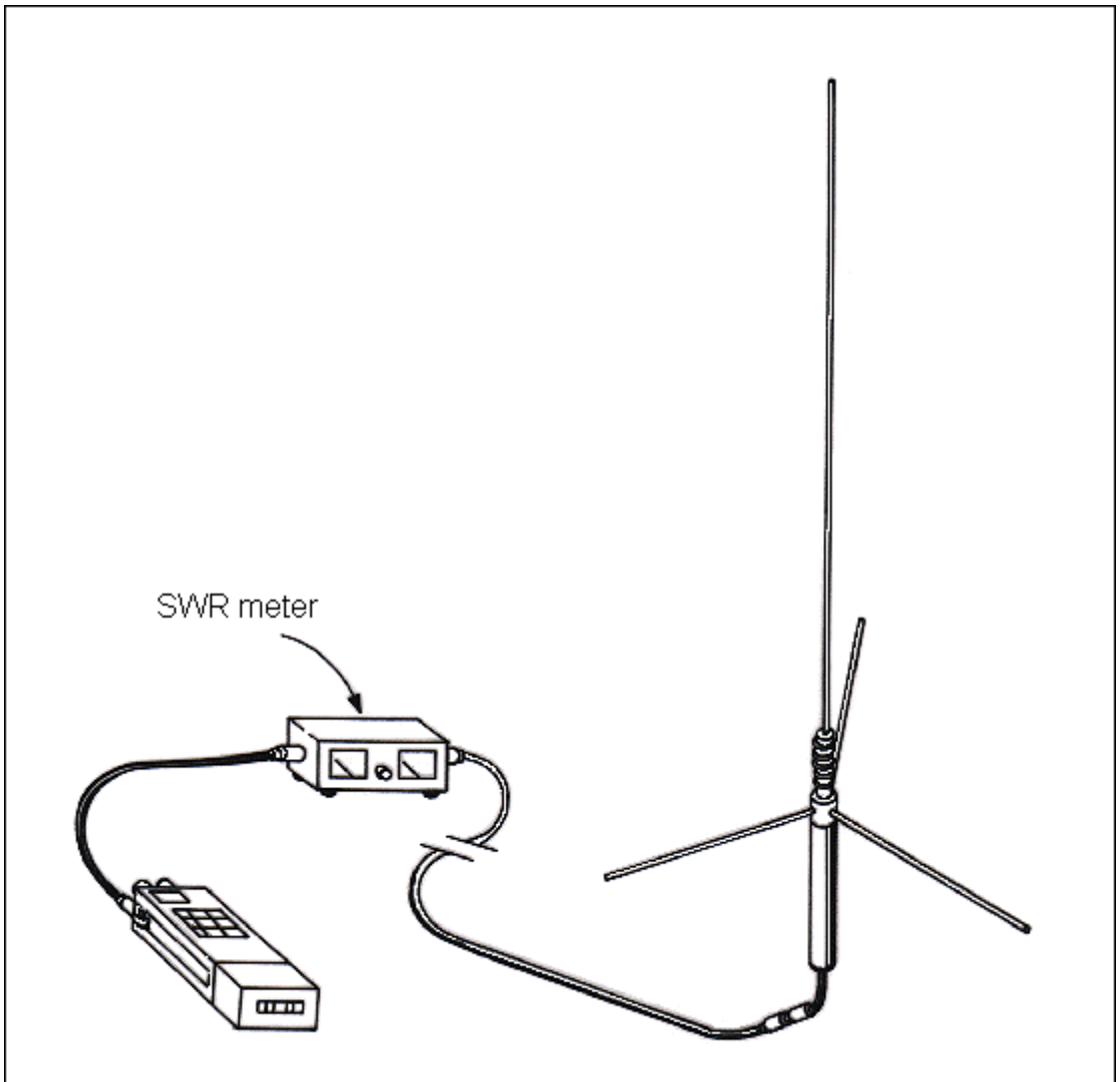

Figure 11.17 Preparing the antenna for tuning to resonance.

Set your transceiver's frequency to the center of the band and key the PTT. Read the SWR response and write it down to a chart similar to the one shown in Figure 11.18.

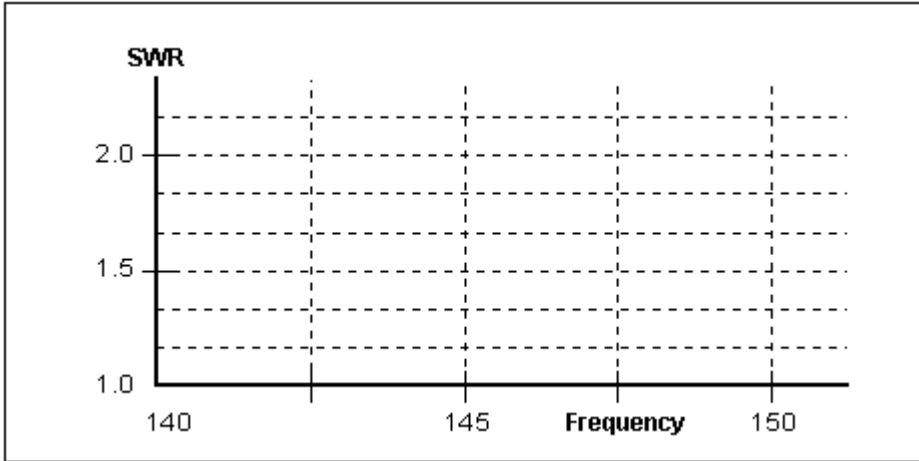

Figure 11.18 SWR chart.

Resolder the hook-up wire to another point in the copper coil to get the lowest SWR response in the center frequency and a relatively flat response over the entire band similar to the charted response shown below (see Figure 11.19).

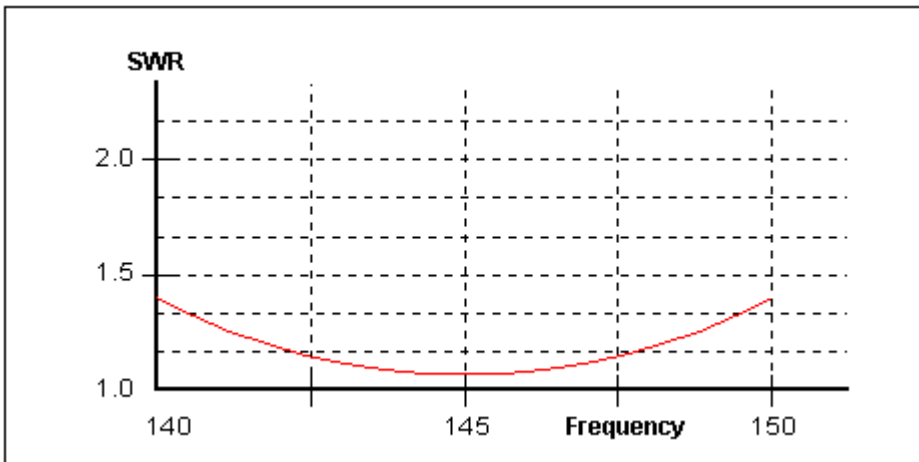

Figure 11.19 A sample of a charted SWR response.

You can move the soldered point or tap either way - left or right - depending on how the SWR responses. If you have moved the tap to the right and the SWR went higher then obviously you must move the tap to opposite direction - to the left. You must check the SWR reading over the entire band everytime you move the tap. Move the tap only about 1/4 inch farther each time. After you have found the best point in the copper coil, solder the hook-up wire permanently (see Figure 11.20).

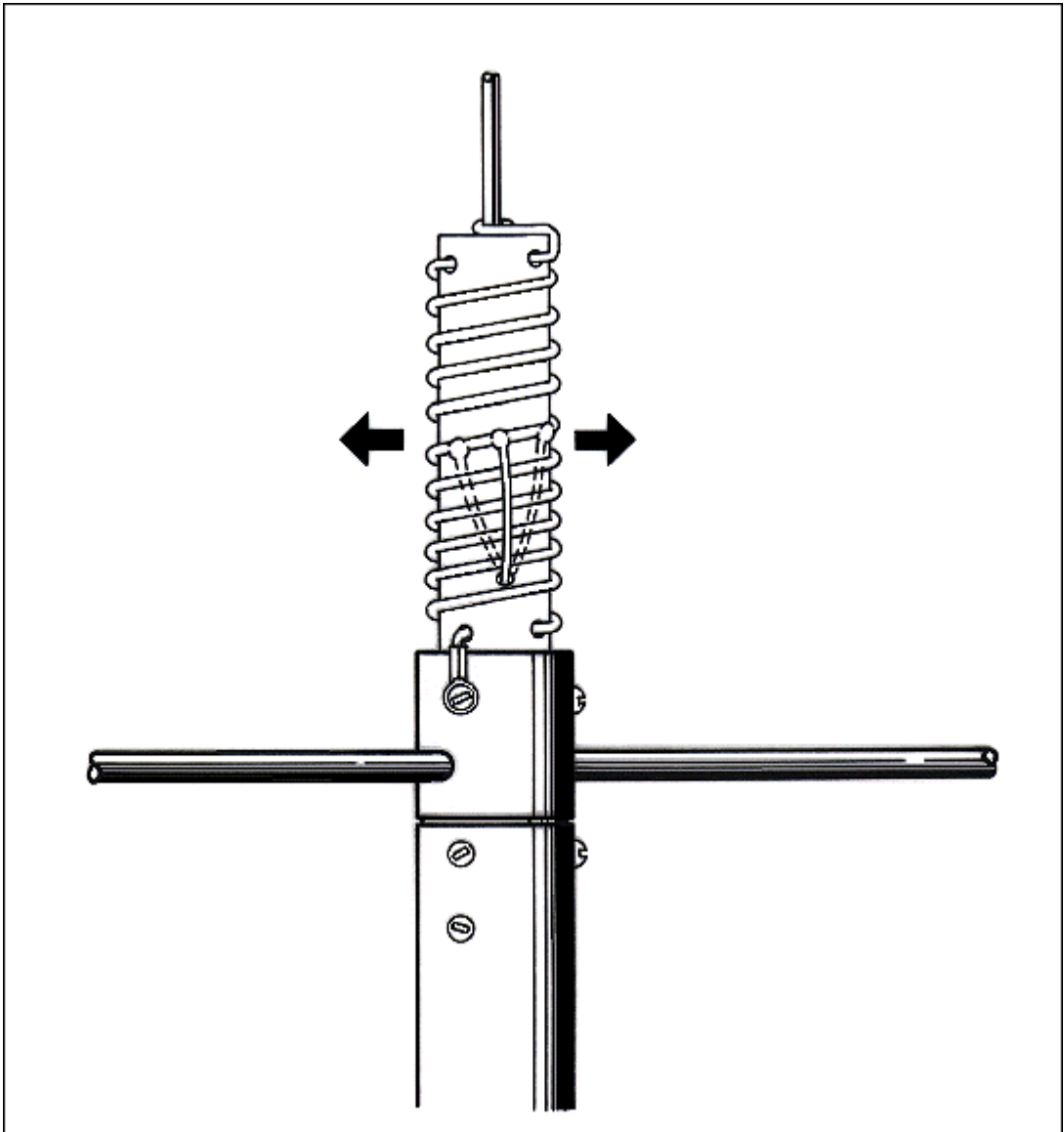

Figure 11.20 Resoldering the tap to a different point to find the best SWR response.

Dismount the antenna from the mast and remove its three groundplane radials. Place the heat shrinking tube into the antenna wrapping the entire coil form and heat it over a flame or with a blow drier. The coil form and shrinking tube must be rotated continuously over the heat to result to an even shrinking of the tube (see Figure 11.20). If you are heating the tube over the flame, don't let the flame touch the tube directly.

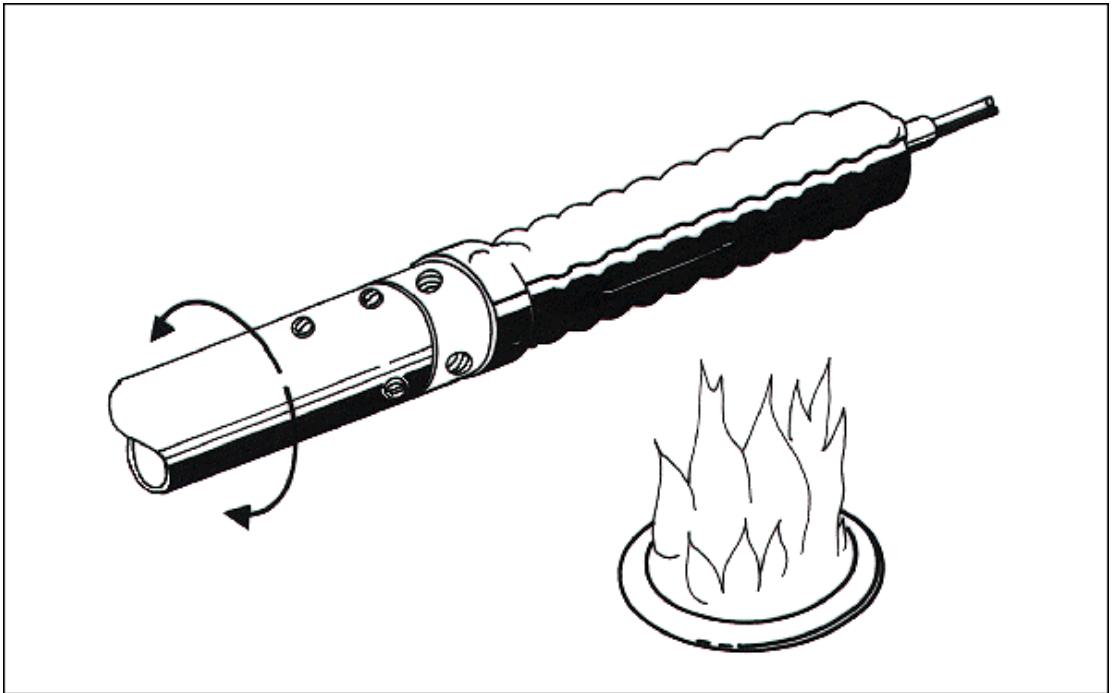

Figure 11.21 Heating the shrinkable tube.

12

5/8 WAVE ANTENNA

Model WD-2

This antenna is an improvement of the basic design of 5/8 wave vertical with radials. As can be clearly seen in the following illustration, it has two metallic cones attached to a long tube which doubles as support for the radiator element. The cones are not intended for novelty but serves a very important purpose for a more efficient performance of the entire antenna system. Its function is to nullify the unbalanced coupling between the transmission and the antenna feedpoint and prevent the unwanted current from flowing on the outside of the coaxial cable.

Why is this so?. Well, let us first go back to some basics to understand this phenomenon. In a perfectly balanced antenna the electrical current within each leg of the element is symmetrical. There will be no problem in coupling the RF signal to its feedpoint when a balanced feedline is used. However, if a coaxial cable is used to feed the antenna, the coupling action is inherently unbalanced because of the

physical construction of the coaxial cable. Stated simply, the outside part of the outer conductor is not coupled to the antenna in the same way as its inner part is coupled to the inner conductor. The overall result is that current will flow on the outside of the outer conductor. This current is negligible in the HF frequencies but must not be ignored in VHF or UHF frequencies. This problem is remedied by the metal cones described in this particular model - it detunes the system for stray currents present on the outside of the line. The cones are also called "detuning sleeves" or "decoupling sleeves".

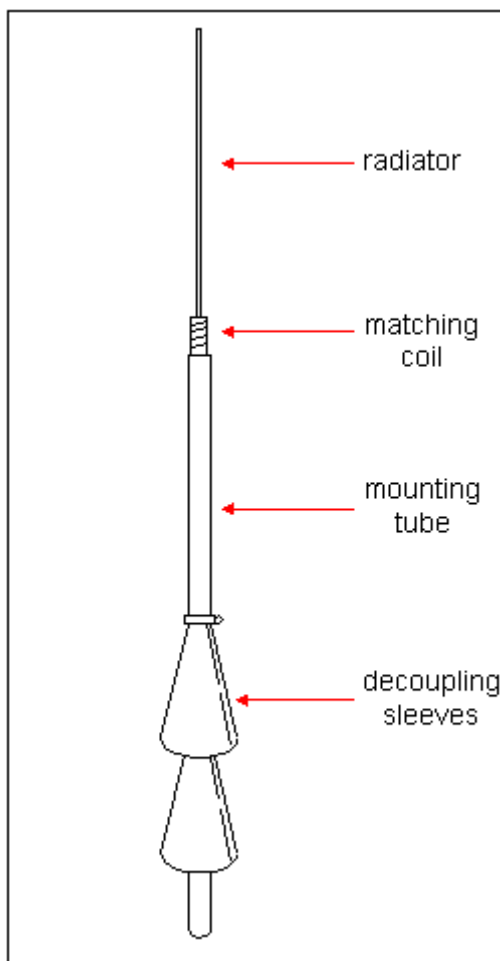

An antenna system with a properly decoupled line is commonly used in repeater systems because by the very nature of its design, a repeater station is very sensitive to any kind of stray RF signal. A repeater station has both receiver and transmitter units simultaneously operating when used. Although the frequency of the transmitter unit is different from the frequency of the receiver unit, the very close proximity of the two units tends to blank out the generally weak signals from distant stations. This results to a phenomenon called "desensitiation" or "desense" where the repeater cannot receive the signals from the user stations.

Feedback also results to loud squeal heard by the users. The entire system ceases to function as a repeater then. Desense and feedback is avoided by using high-Q cavity filters inserted in the transmission line for the transmitter or receiver antenna or both.

Additionally, the automatic switching electronics of the repeater is also protected against picking up unwanted RF by enclosing it in a metal box and by extensive use of decoupling circuits in all the leads going in and out of the box. However all of these efforts could fail if the stray current that travels along the outside part of the transmission line is so strong that it penetrates all filters installed in the repeater system. Using a decoupled antenna system such as the one described in this chapter will save you from the trouble.

The model WD-2 is specifically dimensioned to operate in the 140-150 MHz band. It exhibits an SWR response of less than 1.5:1 over the entire band. The radiation pattern is omni-directional. It has a gain of 1.8 dB compared to a standard dipole reference.

Materials needed

This antenna is basically the same with the antenna model WA-2. The difference between the two models is that the mounting tube for the model WD-2 is 104 inches long and has no groundplane radials but instead it has two decoupling sleeves made of metal cones attached to the lower portion of the mounting tube.

Construction

Construct the antenna following the procedures described for the model WA-2 in chapter 11 except for the length of the mounting tube which is 104 inches long for the model WD-2. Also skip the procedure for preparing the groundplane radials, you don't need them for this antenna anyway. Furthermore, before you tune the antenna to resonance, construct the decoupling sleeves and attach them to the mounting tube following the procedures described here.

Cut the cone form from a metal plate (GI sheet or aluminum) following the dimensions shown in Figure 12.2. In forming the cone, overlap its edges and drill holes along the edge. Rivet the overlapping edges through these holes.

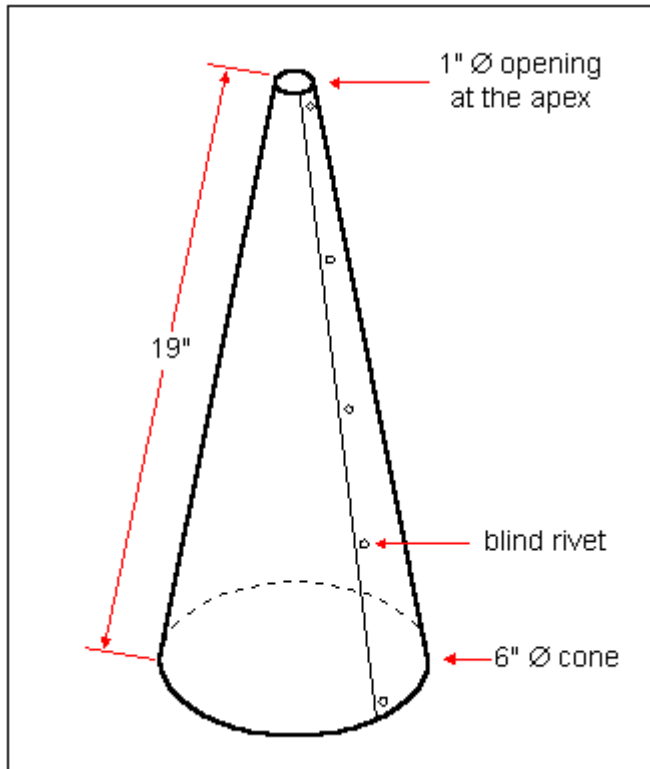

Figure 12.2 Fabricating the decoupling sleeve (or 'decoupling skirt').

Cut a narrow strip out of a similar material and form it to a ring with a diameter of 1 inch as shown. Leave a small gap between the two ends. This ring will serve as a mounting sleeve so that the decoupling sleeve or skirt can be securely clamped to the mounting tube (see Figure 12.3).

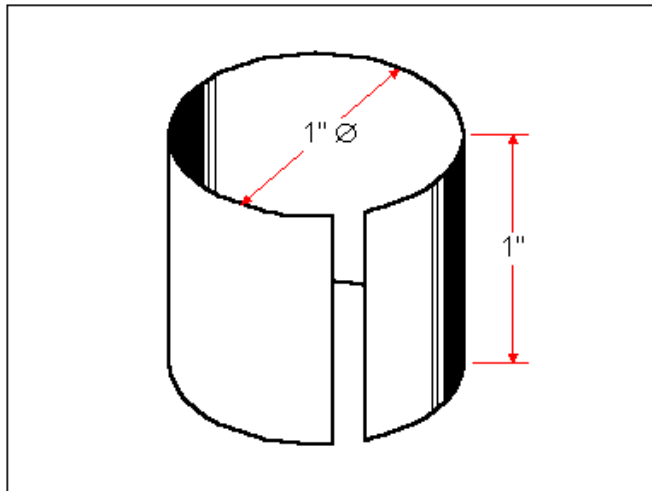

Figure 12.3 Preparing the metal ring.

Solder the ring to the apex of the cone (see Figure 12.4). If you use an aluminum plate you must electrically weld the two pieces together using a special welding technique with protective gas.

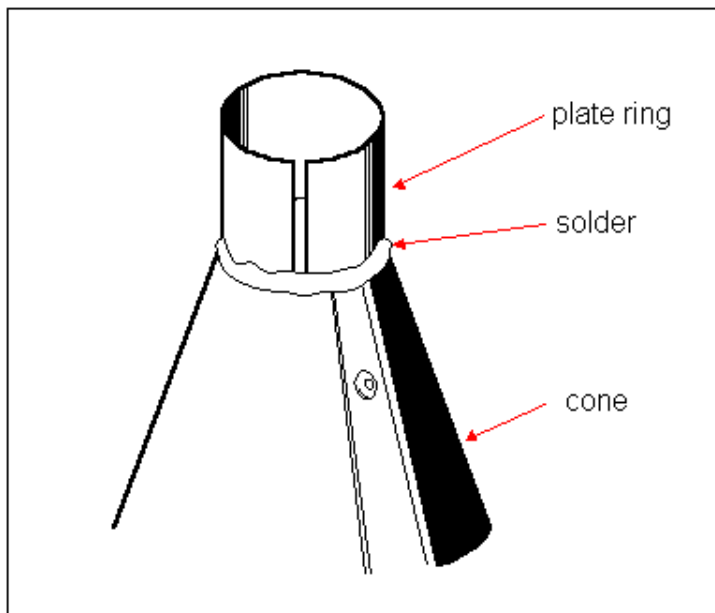

Figure 12.4 Soldering the ring to the cone.

Attach the two decoupling sleeves/skirts into the mounting tube following the distances shown in Figure 12.5. Place a tube clamp over each cone and tighten it to secure the cones firmly to the mounting tube (see Figure 12.6).

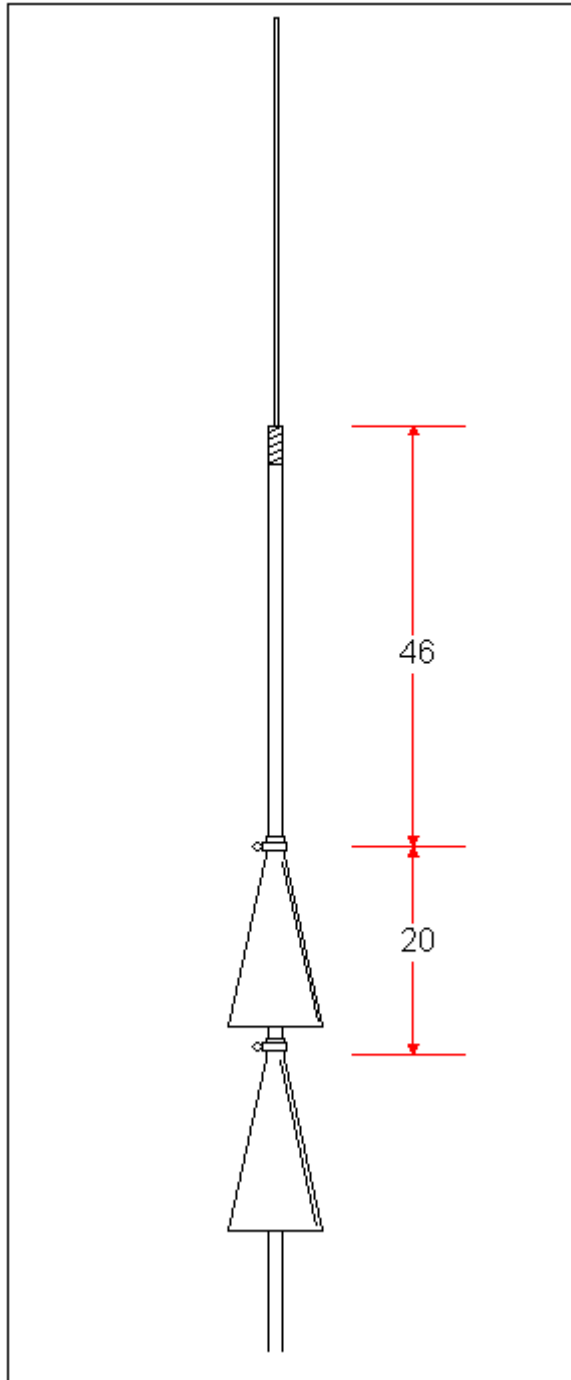

Figure 12.5 Mounting the decoupling sleeves to the antenna.

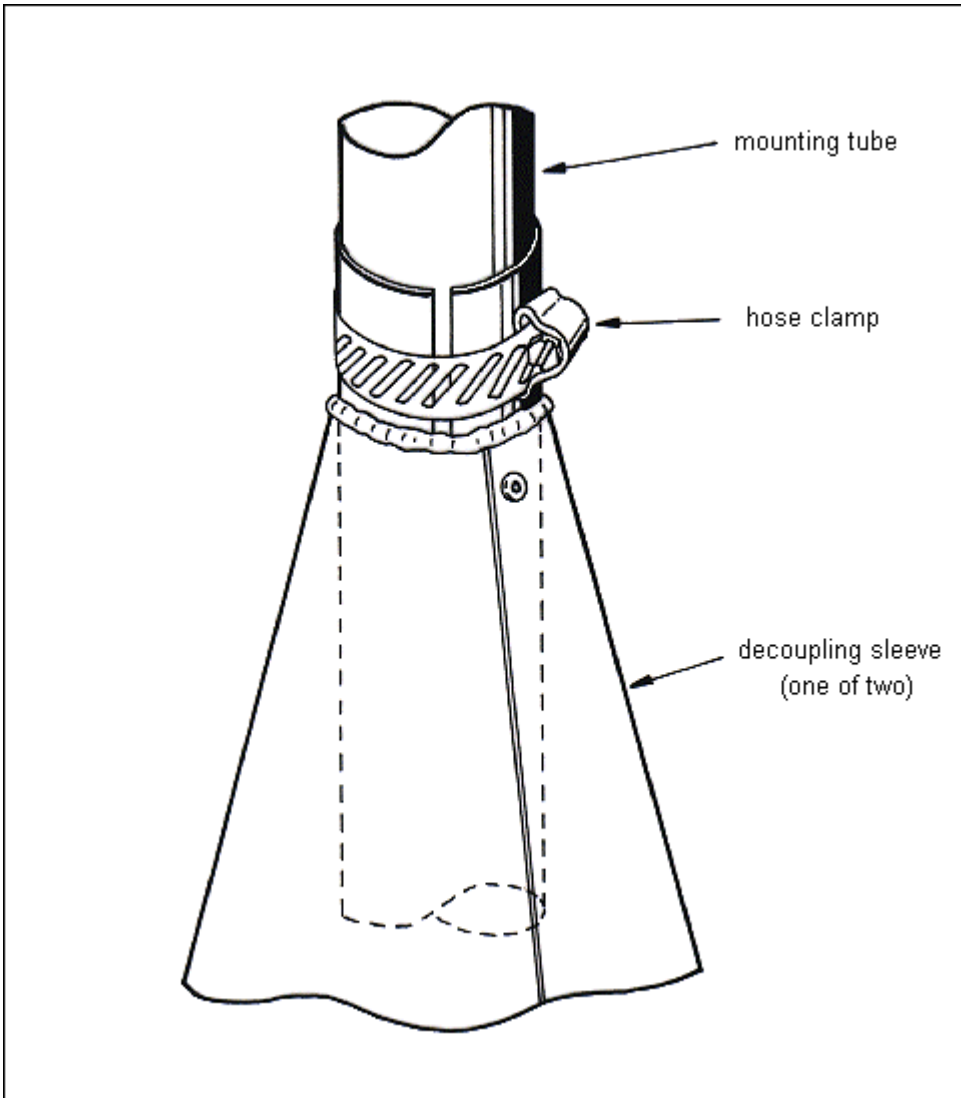

Figure 12.6 Securing the cone to the mounting tube with a hose clamp.

Tuning the antenna to resonance

The tuning procedure for this antenna is the same with the procedure for tuning the antenna model WA-2. Just follow the procedures described in chapter 11.

INSTALLATION

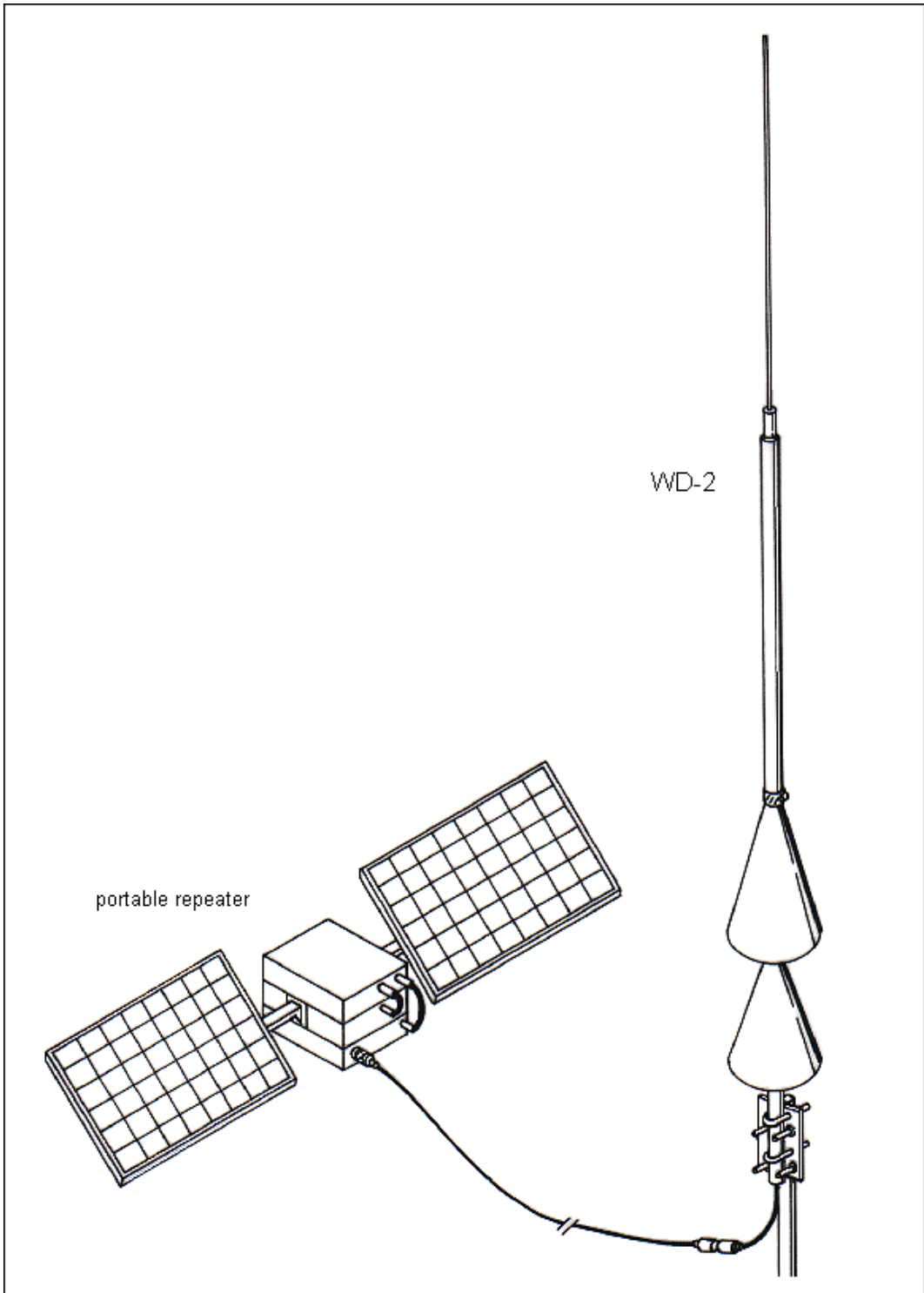

Figure 12.7 Mounting the WD-2 to the mast.

13

5/8 WAVE ANTENNA

Model PF-2C

Most mobile operators use portable handheld transceivers because these are lightweight and small. There are also available models today that equal the capabilities of their base station versions in terms of frequency coverage, sensitivity, computerized functions, PLL stability and many other unique features. However, portable transceivers in general have low power transmitters because of obvious limitations in the type of batteries practically allowable for mobile operations. The average transmitting power of handheld units range from 0.5 watts to 5 watts maximum. Because of this, most antennas used for portable sets are of gain type to increase the effective radiated power.

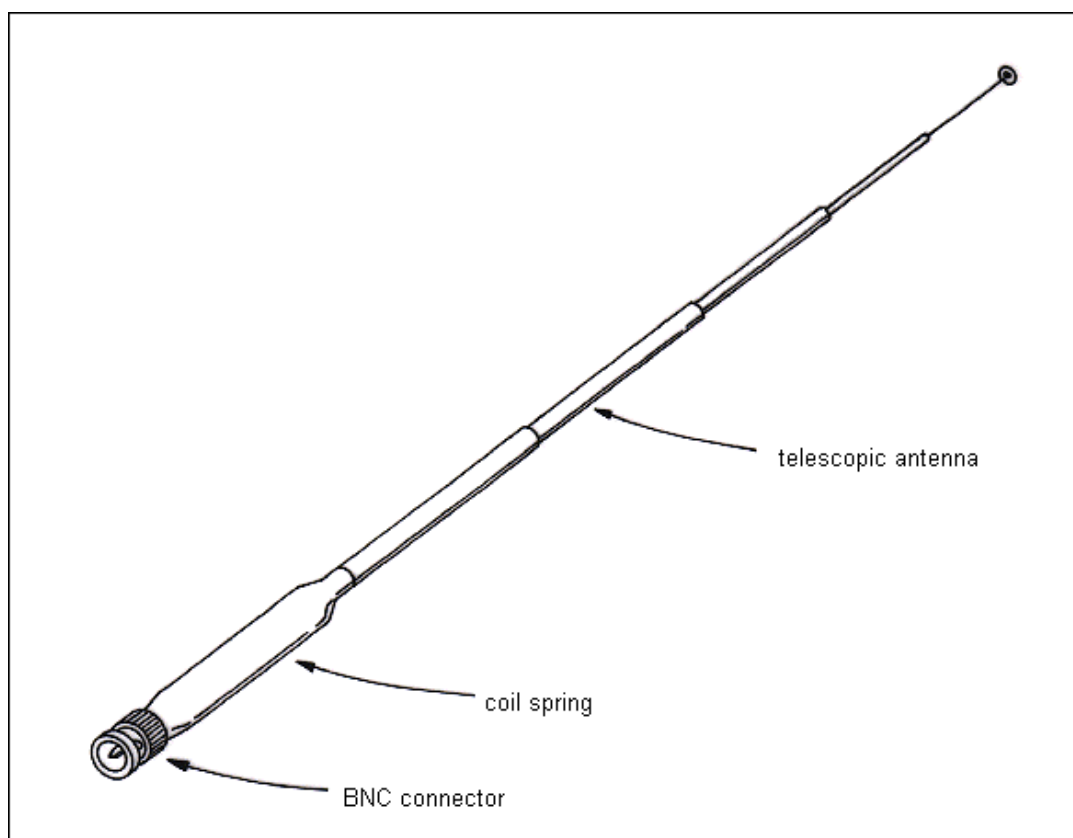

Figure 13.1 5/8 wave antenna model PF-2C.

The antenna described here is a portable version of a 5/8 wave vertical antenna. As stated earlier, an antenna of this length has a slight gain over a dipole. Approximately, a gain of 1.8 dB can be attained with this type of antenna. The radiator element of this model is made of telescopic rod so that the overall length of the antenna can be reduced if desired. It is loaded at the base by a coil that doubles as a flexible spring supporting the telescopic rod. The telescopic element may be used while retracted or collapsed and will function like an ordinary "rubber ducky" antenna that comes as a standard accessory for portable transceivers. Gain can only be realized if the antenna is used while the radiator is extended to full length.

Sometimes it is desirable to raise the height of the antenna to increase its effective range. Installing the antenna to a higher position clears it from most obstructions such as houses or trees and extends the horizon farther away thereby increasing the area covered or "seen" by the antenna. This can be accomplished by using a length of coaxial cable to connect the antenna to the transceiver. The antenna is then mounted high up in a post or tower. It can also be hung under a tree by using a non-metallic material such as nylon or fishline.

This particular model is dimensioned to operate in the frequency band of 140-150 MHz. It exhibits an SWR of less than 1.5:1 over the entire band if properly tuned. Tuning is easy as described in this chapter. The materials used for this model can be bought cheap and constructing it can save a lot of money. The total cost of the antenna is a mere fraction of the price of its commercial version. Furthermore an invaluable knowledge can be gained during the actual construction of this antenna.

Materials List		
Quantity	Specification/Description	Dimensions
1	Telescopic antenna - approx. 7/16" od* of the base tube	46" fully extended 6" to 7" retracted
1	Brass wire no. 26 or approx. 3/32" diameter	24" or 60 cm.
1	BNC VHF male connector	
1	10 pF/150 Volts capacitor glass type	
1	Hook-up wire no. 22 stranded	4" long
1	Heat shrinkable tube	5/8" or 3/4" od* x 4" long
Miscellaneous: Epoxy glue		

- od - outside diameter

Construction

Wind the brass wire into a spring like coil form. Wind 13 turns of the wire with a pitch of approximately 4 turns per inch. The total length of the finished coil is approximately 3 inches (see Figure 13.2). The inside diameter of the coil spring must be force fit to the outside diameter of the BNC connector or approximately 3/8" id*.

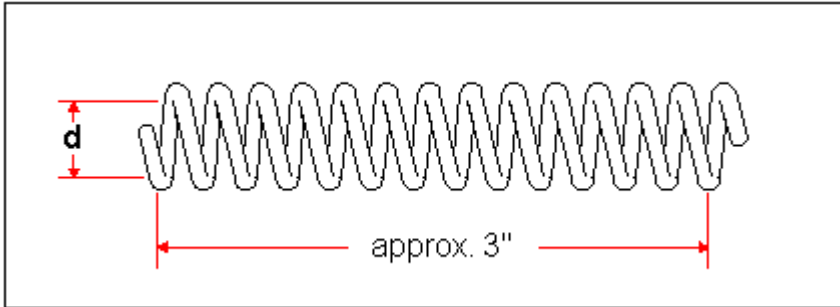

Figure 13.2 Constructing the spring coil.

*id-inside diameter

Solder about 2" long hook-up wire to the center pin of the BNC connector.

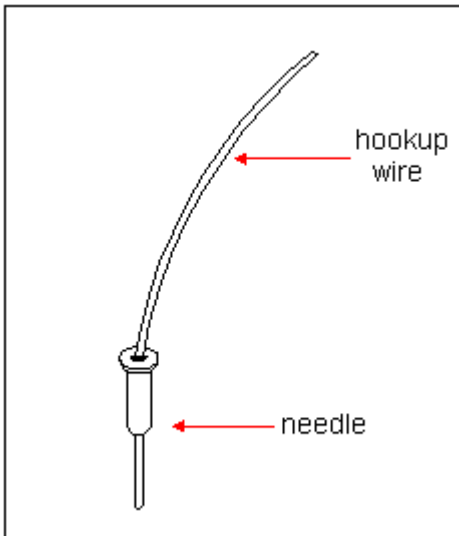

Figure 13.3 Soldering the hook-up wire to the center pin of BNC.

Place a moderate amount of epoxy glue around the soldered part of the needle. Avoid coating the epoxy around the body of the center pin. Insert the needle into the BNC connector and cover the empty space inside with a liberal amount of epoxy (see Figure 13.4). Let the epoxy cure and harden.

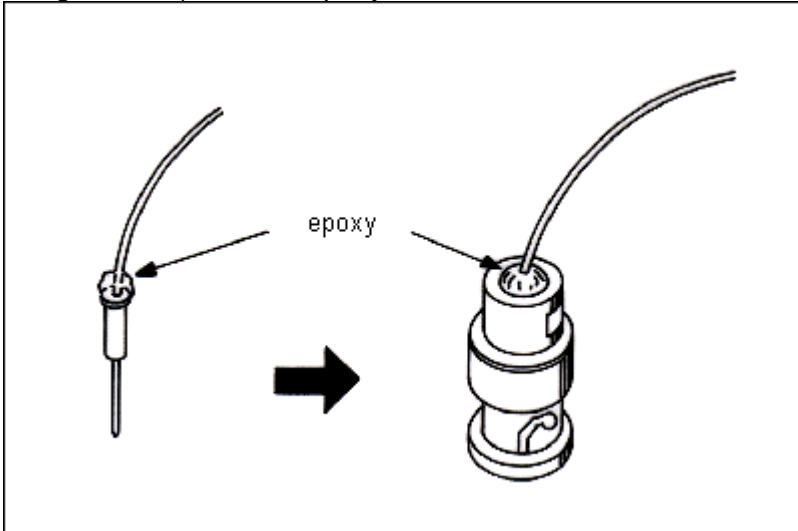

Figure 13.4 Fixing the center pin to the BNC connector with epoxy glue.

When the epoxy hardens insert the BNC connector into one end of the spring coil. Solder the part of the coil that wraps around the body of the BNC connector (see Figure 13.5).

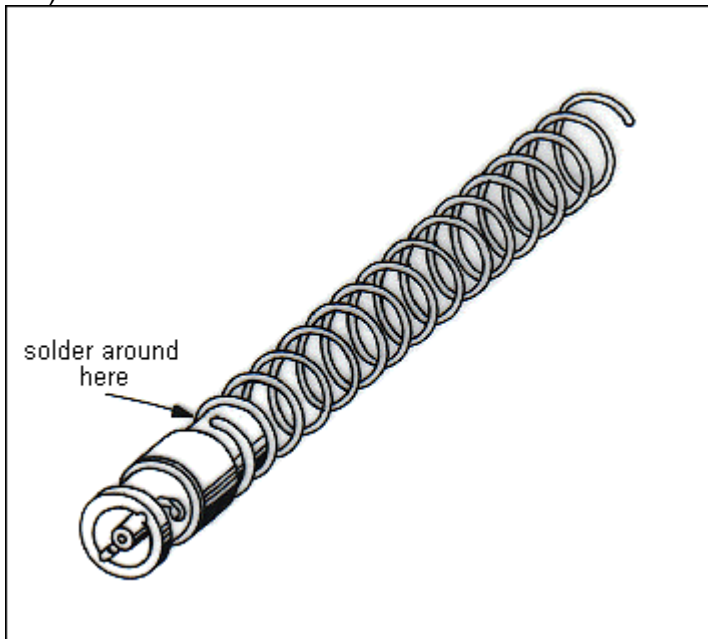

Figure 13.5 Assembling the BNC connector and the spring coil together.

Pry out the free end of the hook-up wire inside the coil spring and solder it to the point of the coil which is 1 and 1/2 turns counting from the ungrounded portion of the coil (see Figure 13.6).

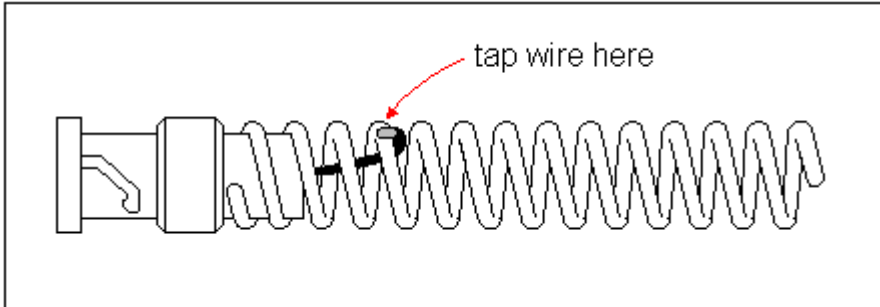

Figure 13.6 Soldering the hook-up wire to a temporary tap point.

Insert the 10 pF capacitor inside the spring coil and solder its lower lead to the grounded portion of the coil (see Figure 13.7).

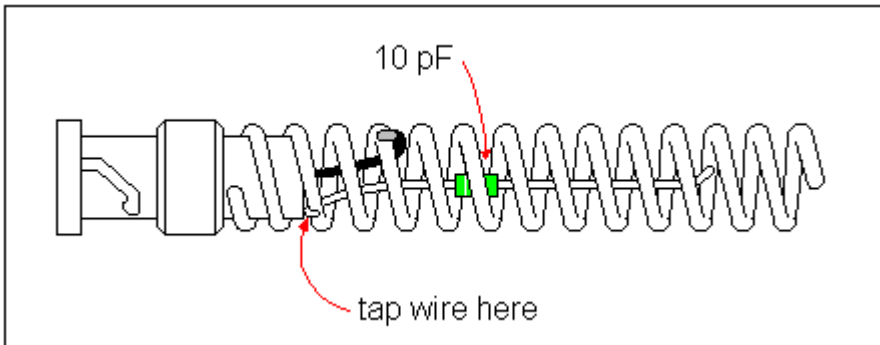

Figure 13.7 Soldering one lead of the capacitor to the grounded portion.

Next, solder the upper lead of the capacitor to the 6th turn of the coil spring counting from the ungrounded portion. See Figure 13.8.

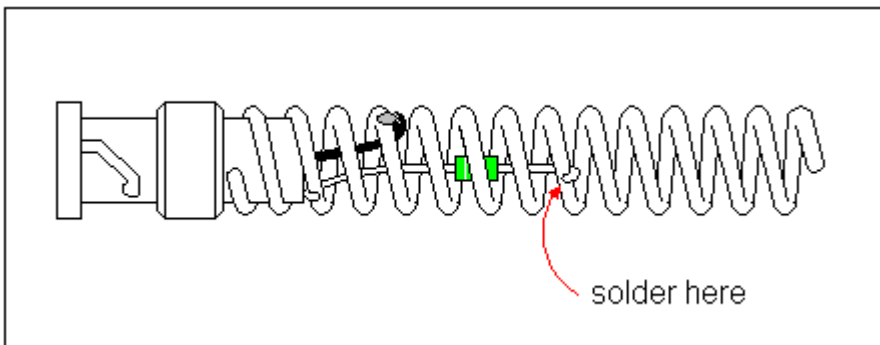

Figure 13.8 Soldering the upper lead of the capacitor.

Next step is to insert the base of the telescopic antenna into the open end of the coil spring. Let 2 turns of the coil hold the base of the antenna and solder it to secure the two pieces together (see Figure 13.9). At this point the construction of the antenna is already finished, it only needs to be tuned to resonance for proper operation.

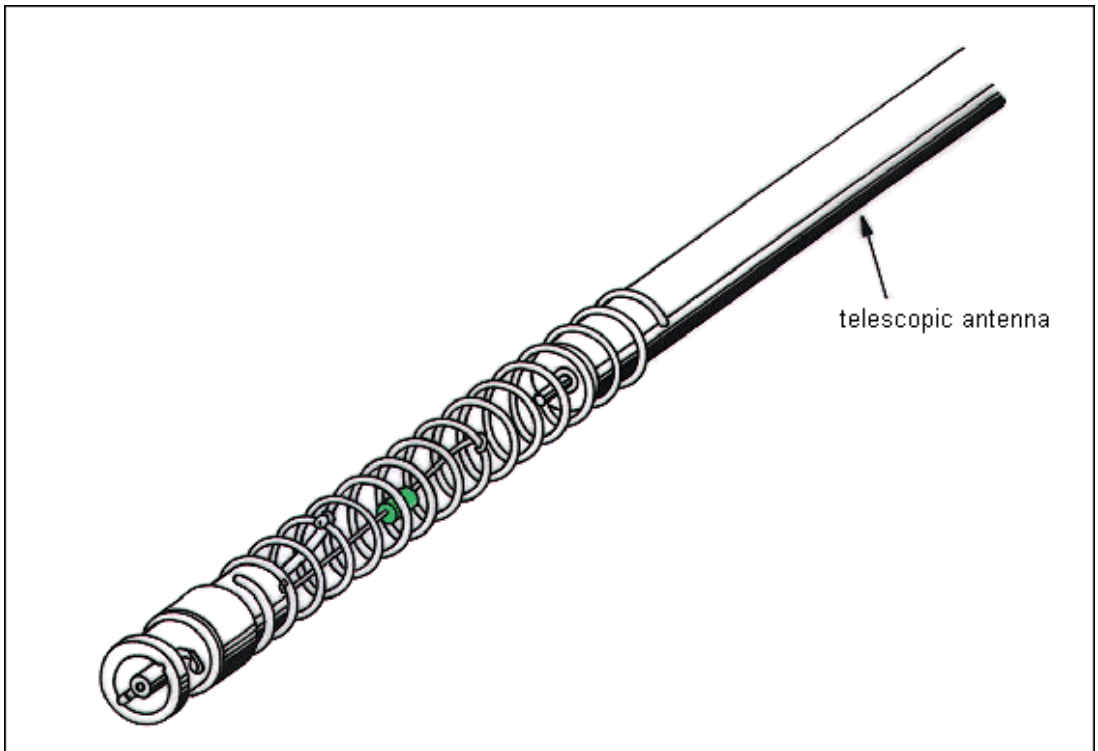

Figure 13.9 Final assembly of the antenna.

Tuning the antenna to resonance

Attach the antenna directly to the output connector of the SWR meter using the necessary adaptors. Similarly, connect the SWR meter to the transceiver using a short length of coaxial cable (see Figure 13.10).

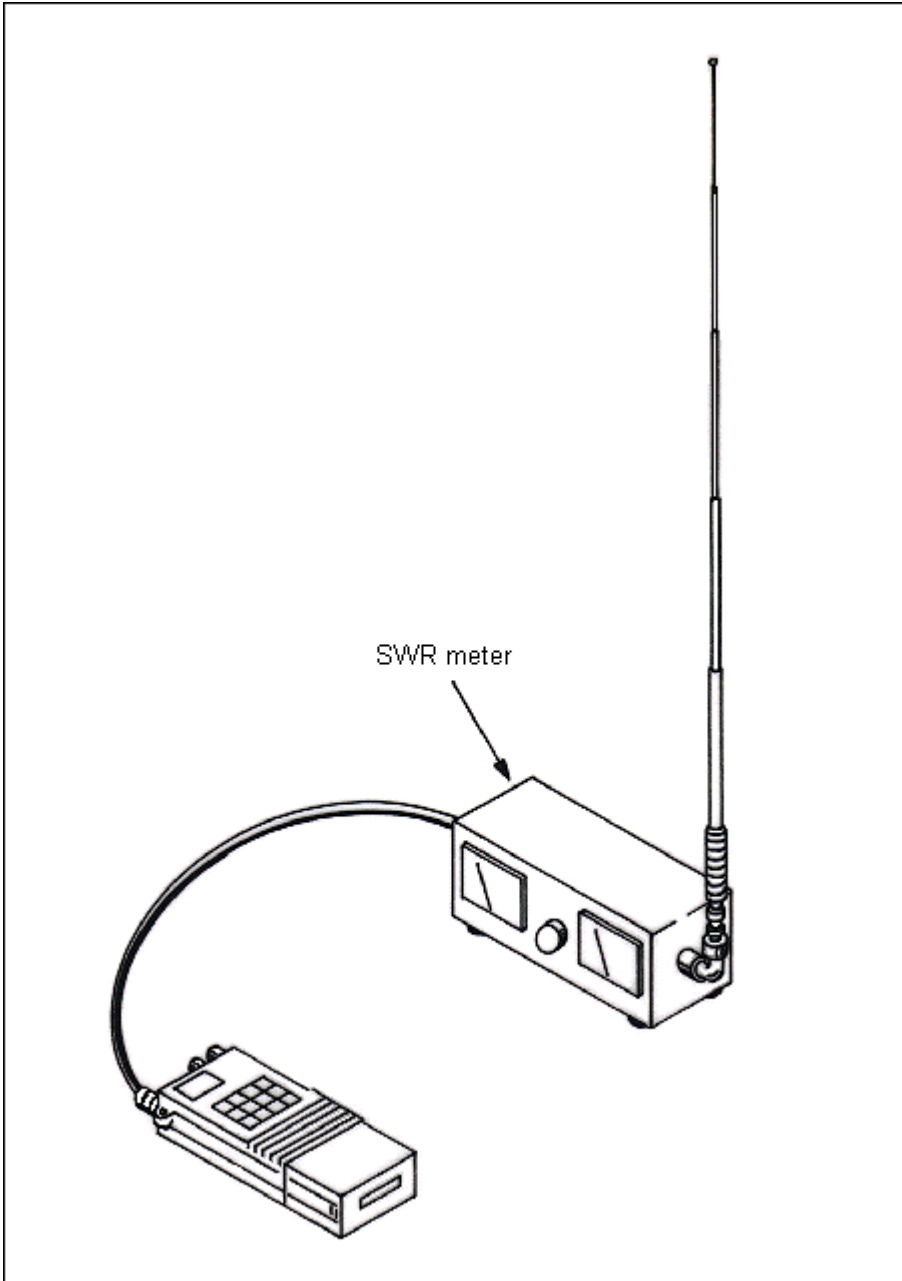

Figure 13.10 Preparing the PF-2C for resonance tuning.

Set the transceiver to the center frequency and key the PTT. Read the SWR response and note it on a chart similar to the one shown in Figure 13.11.

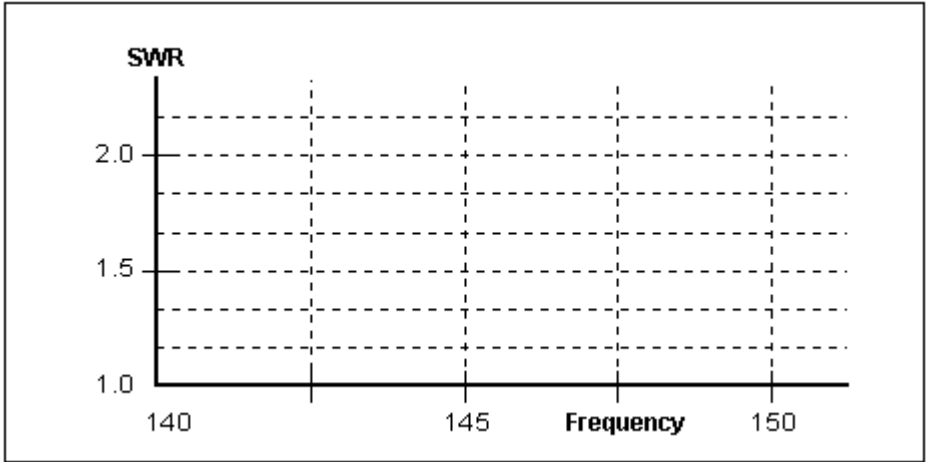

Figure 13.11 A sample chart for SWR readings.

Read all the SWR responses from the lowest frequency up to the highest frequency in the band and mark all the results on the chart until you get a response curve similar to the one shown in Figure 13.12.

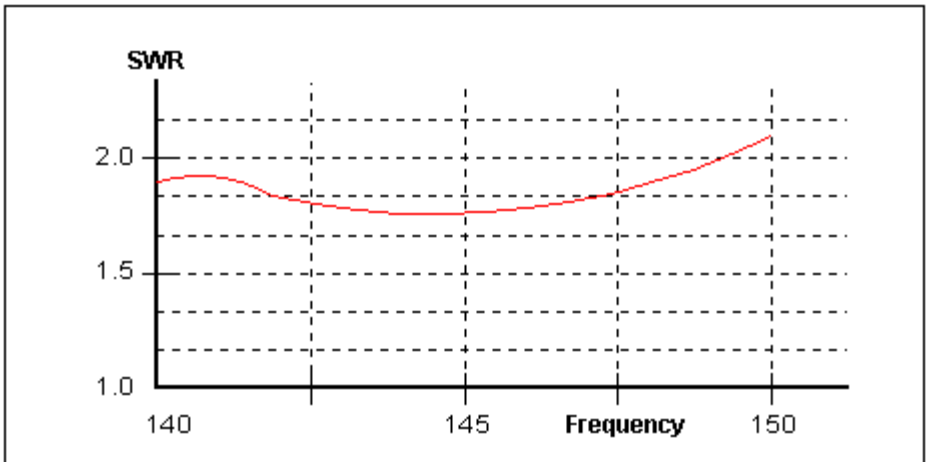

Figure 13.12 A sample of an SWR curve.

Resolder the capacitor's lead to a different point or tap either to the left or right of the original tap. If you have moved the tap to the right and the SWR went up then obviously you must move the tap to the left. Key again the PTT and mark the SWR responses once again on the chart. Move the tap about 1/8" farther at a time (see Figure 13.13).

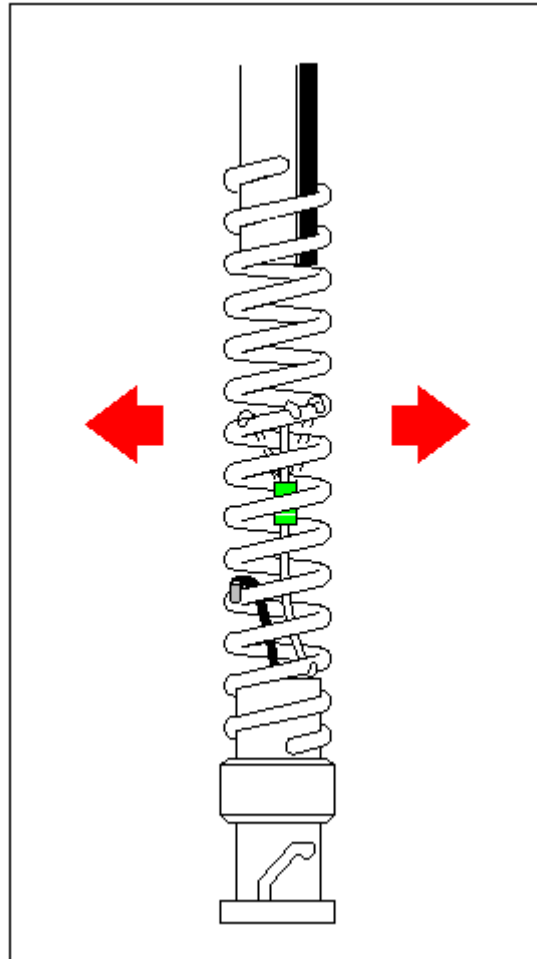

Figure 13.13 Resoldering the capacitor's lead to find the right tap.

Repeat the whole process until you find the point in the coil that results to a very low SWR reading on the center frequency and relatively balanced responses on the extreme ends of the band. If you have followed the instructions in constructing this antenna carefully, it is possible to get an SWR response of 1.1 at the center frequency and 1.5 at extreme ends of the band similar to the response curve shown in Figure 13.14.

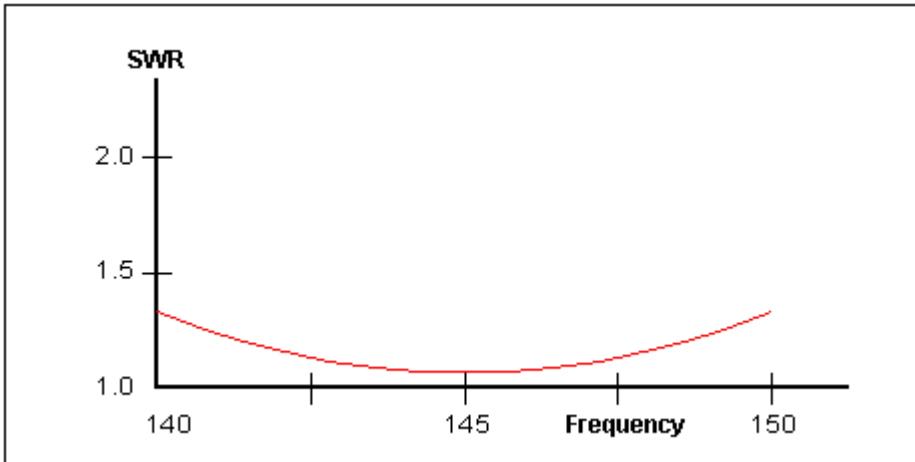

Figure 13.14 A sample of a good SWR response.

After you have found the right tap, solder it to the coil spring permanently. Insert the spring coil into the heat shrinkable tube and heat the tube over a flame or with a blow drier. Rotate the antenna and the tube continuously while being heated to get an even shrinking of the tube (see Figure 13.15).

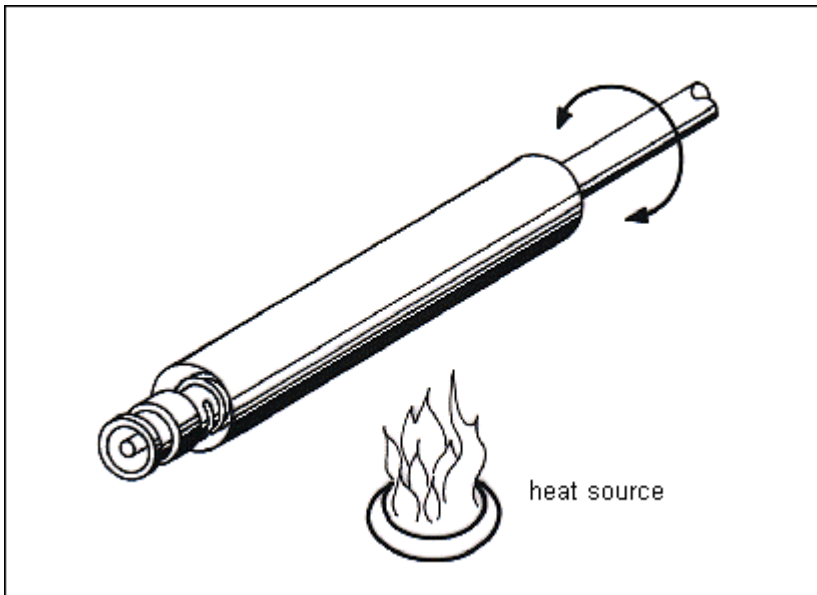

Figure 13.15 Heating the shrinkable tube.

14 COLLINEAR ANTENNA

Model SD-22 (2 stacked dipole)

A collinear antenna is made up of a multiple number of dipoles mounted in a common structure with their axis arranged in one straight line. The dipole elements are always driven in phase otherwise the array simply becomes a harmonic type antenna. A collinear array is a broadside radiator, meaning the direction of maximum radiation is at right angles to the line of the antenna.

When mounted vertically, it radiates an omni-directional pattern. One advantage of this design is its ability to attain high gain. When dipole elements are stacked collinearly, the power gain increases in direct proportion to the number of dipoles used. Obviously, this type of antenna is limited to fixed installation only because of its mechanical construction.

An actual working design of a collinear array is presented here. It has two identical dipoles fed with a coaxial phasing line or 'harness'. Each dipole element is tuned by a gamma matching system similar to that described in chapter 6. In fact, it is the same design of dipole just 'doubled' and fed simultaneously. This configuration gives a gain of 3 dB compared to a single dipole.

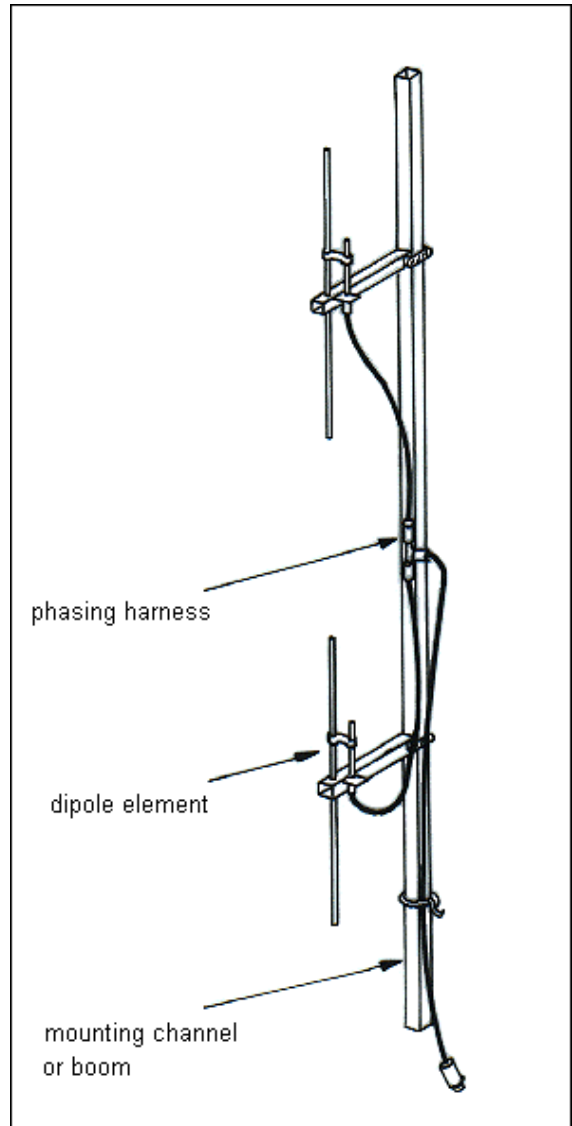

This model is dimensioned to operate in the frequencies of 140-150 MHz band. It has an SWR response of less than 1.5:1 over the entire band. Tuning procedure is similar to that described for dipole model DP-2.

Materials needed

Most of the materials needed to build the antenna model SD-22 are the same with those needed for antenna model DP-2 except for the mounting channel. The mounting channel for SD-22 is shorter being only 8 inches long and has slits on two sides instead of two holes.

Additionally, another long square channel is needed to mount the two dipole elements into a single mast. Also, a system of phasing harness made of coax cable is required to feed the two dipoles simultaneously. In short the additional materials needed for SD-22 are as follows:

Quantity	Description	Dimensions
2 pcs.	Square aluminum channel	1" x 1" x 8"
1 pc.	Square aluminum channel	1" x 1" x 115"
2 pcs.	Hose clamp	2 - 1/2" clamping capacity
6 pcs.	BNC VHF male connector	
2 pcs.	BNC 'T' connector	

Construction

Follow the procedures for constructing the dipole antenna model DP-2 and make two identical dipoles. The mounting channel for model SD-22 is slightly different and is described in the following illustration (see Figure 14.2).

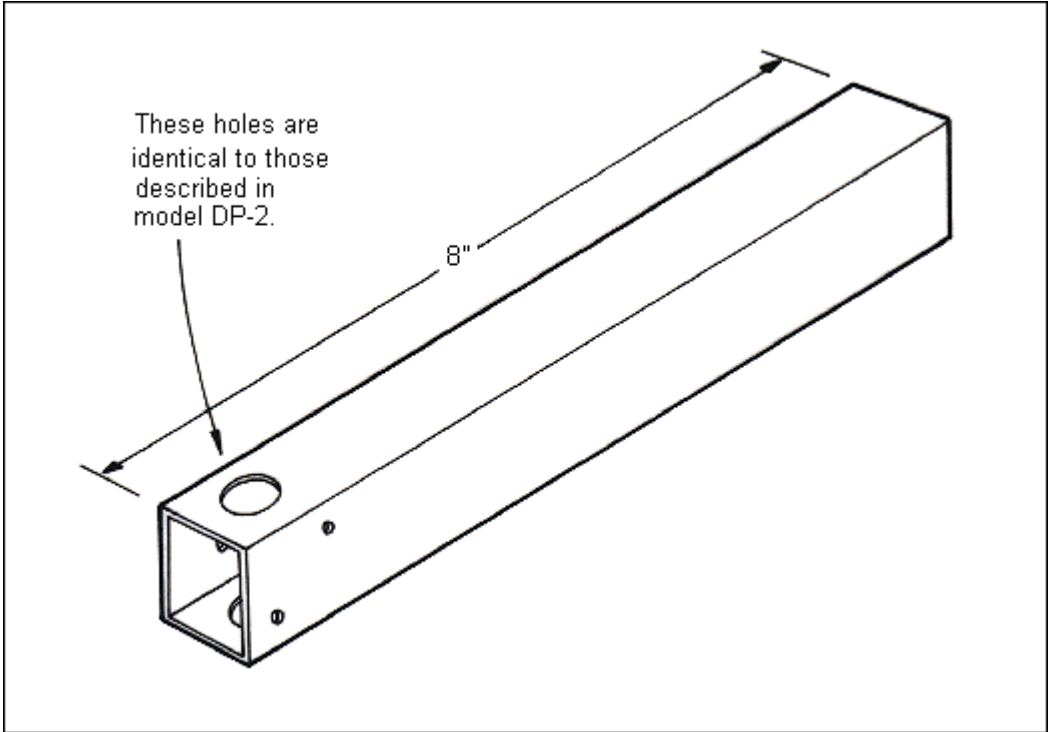

Figure 14.2 Mounting channel dimensions.

Saw shallow slits at two sides of the channel using a hacksaw. A hose clamp will be inserted into these slits for the purpose of mounting the channel to the supporting mast (see Figure 14.3).

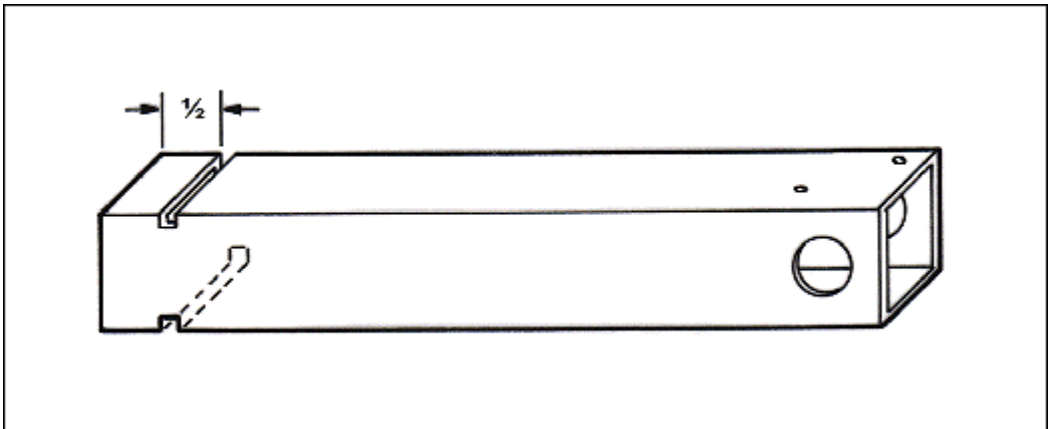

Figure 14.3 Saw slits at two sides of the channel.

Assemble the two dipole elements following the procedures described for antenna model DP-2. After the dipoles are completed, insert the hose clamps through the slits in the channel (see Figure 14.4).

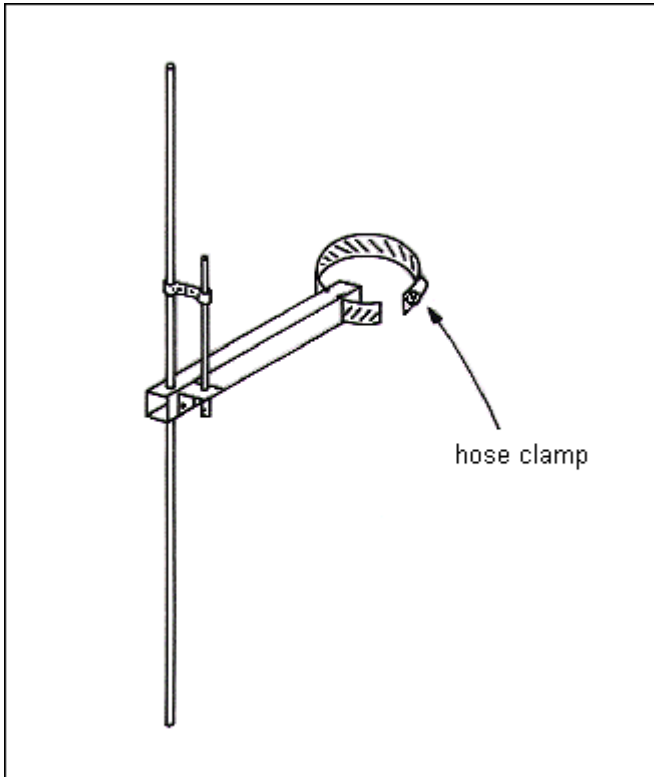

Figure 14.4 Assembled dipole element with hose clamp.

Mount the two dipoles to the aluminum supporting mast following the dimensions shown in Figure 14.5. Wrap the two hose clamps around the body of square channel mast and tighten the clamps to hold the dipole elements rigidly.

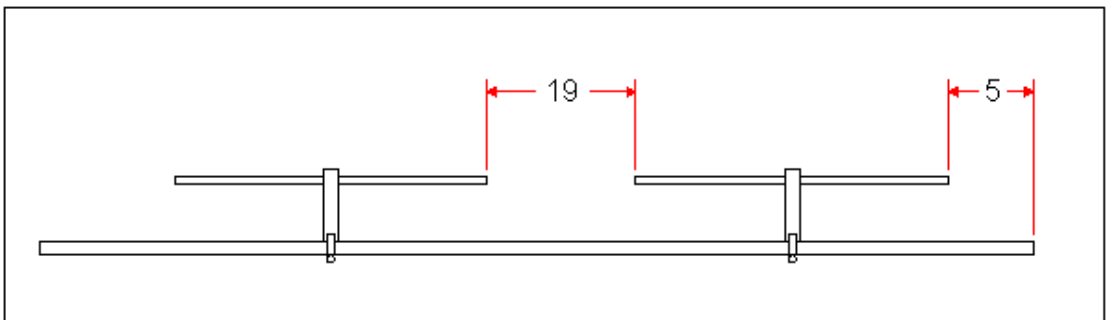

Figure 14.5 Mounting the dipoles to the aluminum mast.

Next, construct the phasing harness using RG-58/U coaxial cables and the appropriate connectors (see Figure 14.6).

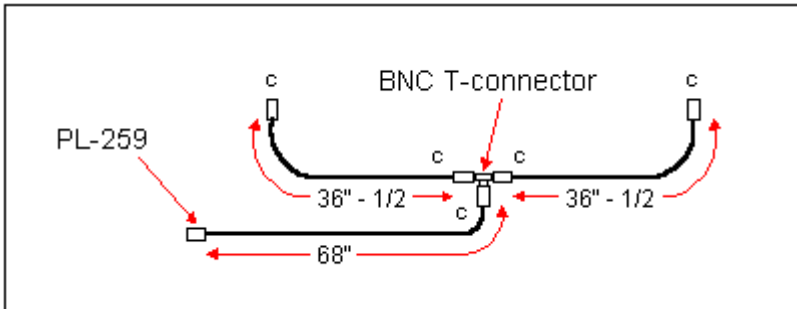

Figure 14.6 Constructing the phasing harness.

Finally connect the phasing harness to the two dipole elements and secure it to the support mast with plastic binders (see Figure 14.7).

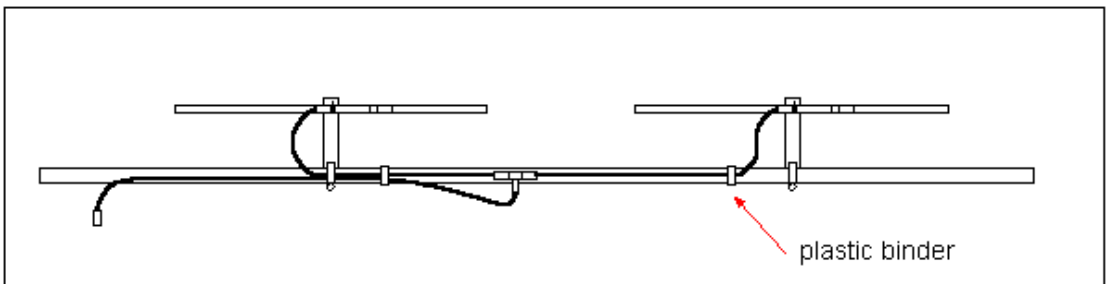

Figure 14.7 Connecting the phasing harness to the antenna.

Tuning the antenna

The tuning procedure for the antenna model SD-22 is similar to the procedure for tuning the antenna model DP-2. In tuning the SD-22 however, the two dipoles have to be tuned simultaneously. You have to do a lot of shuttling back and forth between the two dipoles before you can achieve a good match. If it is not practical to tune the antenna right in the main mast, then it can be tuned on the ground by placing it in a horizontal position with the dipoles facing upward. The antenna must be elevated to not less than 1 meter above the ground supported by non-metallic materials like wooden benches for example.

15 STACKED DIPOLE ARRAY

Model SD-24 (four stacked dipole)

This model demonstrates the capability of a simple dipole to attain high power gain by simply stacking identical units into a single structure and feeding them all simultaneously with a phasing harness. This arrangement is also called collinear array.

As stated earlier in chapter 14, power gain in a collinear array increases in direct proportion to the number of dipole elements used. However, in order to construct a practical phasing harness, the number of dipole elements installed cannot be simply dictated by personal choice. The correct method is to double the original number of dipole units - meaning, if the original array has two dipole elements installed, then the next array must have four dipoles and the next must have eight dipoles and so on. Everytime the number of dipole elements used is doubled, the power ratio is also doubled.

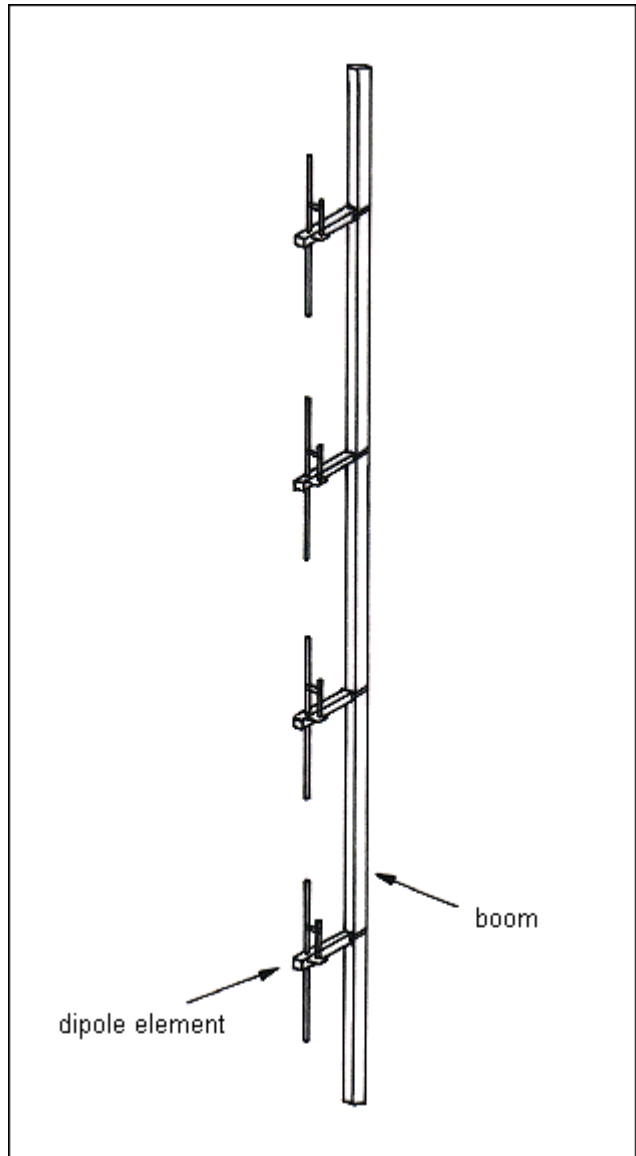



NOTE:

The power ratio is not numerically the same with the dB figure. For accurate computations refer to Appendix.

The particular four-element array presented here has a power gain of 6 dB. A collinear array having eight dipole elements will have a power gain of 9 dB. An array with elements in excess of eight is rarely constructed because of the inherent mechanical problems encountered in erecting structures of this size. Most collinear antennas are mounted vertically to effect an omni-directional pattern of radiation.

The model SD-24 is specifically dimensioned to operate in the frequencies of 140-150 MHz band. If properly tuned, this array exhibits an SWR of less than 1.5:1 over the entire band. The procedure for tuning this antenna to resonance is similar to the procedure for model SD-22.

Materials List

The necessary materials in building this antenna are the same with those needed for SD-22 being its extended version. The square channel used to mount the four dipoles is larger and twice longer than the one used for SD-22. Additional set of phasing harness is also needed to feed the four dipole elements simultaneously.

Additional materials for Model SD-24 are as follows:

1 pc. Square aluminum channel 1-1/2" x 1-1/2" x 235"

4 pcs. BNC male connectors

2 pcs. BNC 'T' connectors

Construction

Construct the four dipoles following the procedures described for models DP-2 and SD-22. Mount the four dipoles to the aluminum supporting channel by using hose clamps. The antenna elements must be attached to the mast with the proper distances from each other (see Figure 15.2).

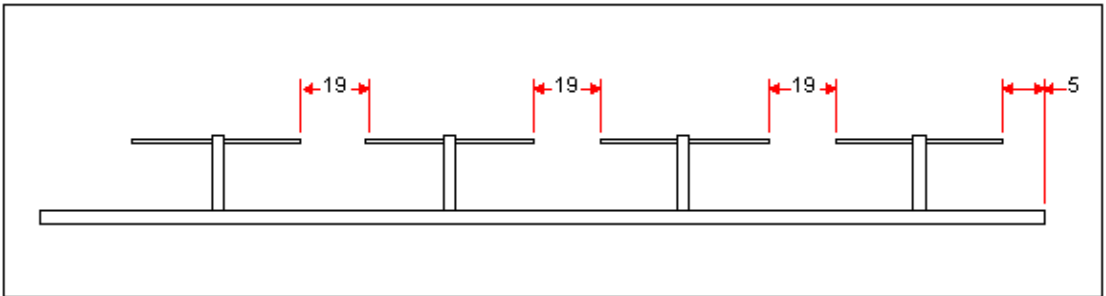

Figure 15.2 Mounting the four dipole elements on the mast.

Construct the phasing harness as shown and attach it to the four dipoles in similar fashion to model SD-22 antenna (see Figure 15.3).

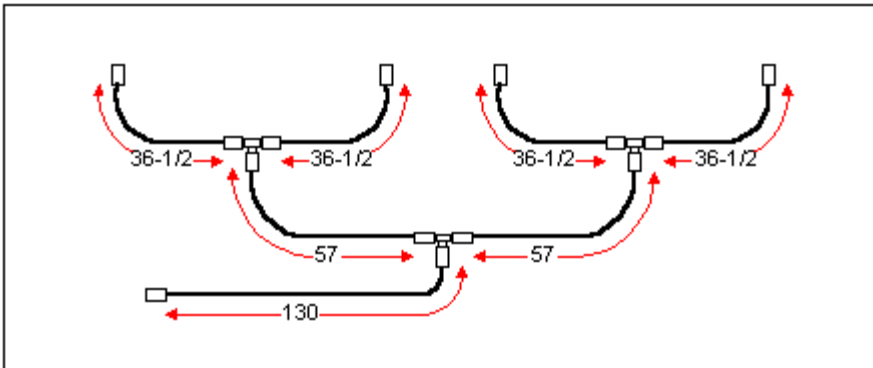

Figure 15.3 Constructing the phasing harness.

Tuning SD-24 to resonance

Tuning the antenna model SD-24 to get a good match is similar to procedures for tuning antenna model SD-22.

16 YAGI-UDA ANTENNA

Model YG-23 (3 element beam)

A yagi-uda antenna is a type of an array having one active dipole and two or more parasitic elements. It was named after the two Japanese physicists who invented it. The basic yagi is one of the highest gain antennas yet developed. Several factors affect the performance of a Yagi. Among these are the number of elements used, their diameter, and the spacing between them.

A basic halfwave dipole is cut to resonance at the center of the frequency band and is utilized as the driven element. High gain is attained by the addition of parasitic elements positioned either in front or behind the driven element. These parasitic elements are called directors and reflectors depending on their length and positioning with respect to the drive element. The reflector is longer by approximately 5 % and is positioned behind the driven element. The director on the other hand is cut shorter by approximately 5% and is positioned at the front of the driven element. The combination of these elements produce the directivity of the radiated signal thus resulting to higher power gain. However, the radiation pattern becomes uni-directional and the much desired omni-pattern is completely lost.

Maximum radiation of signal is now concentrated at the front of the antenna and there is only minimum radiation at the back. The ratio between the radiated signal at the front and the radiated signal behind it is called 'front to back ratio'. Radiation is weakest at the sides of the yagi and these points are called 'null points'. The ratio between the radiated signal at the front and the radiated signal at the sides is called 'front to side ratio'.

This highly directive and uni-directional characteristics of a yagi antenna necessitates the use of a rotator device in order to beam it to the direction of the station in contact. If a rotator device is not used, the high gain character of a yagi becomes useless unless the antenna is intended to be permanently beamed to a single direction such as in the case of fixed point-to-point communication.

The dimension of model YG-23 is specially cut to resonate in the frequency band of 140-150 MHz. If properly tuned, it exhibits an SWR of less than 1.5:1 over the entire band. It has a gain of approximately 7.3 dB compared to a standard dipole reference. This is only a basic configuration of a yagi and its gain and directivity can be increased by adding more directors at the front. Detailed information for the exact dimensions of additional director elements and their spacing is given in chapter 17. These yagi dimensions are based on the information published by the National Bureau of Standards.

Scaled down Appearance

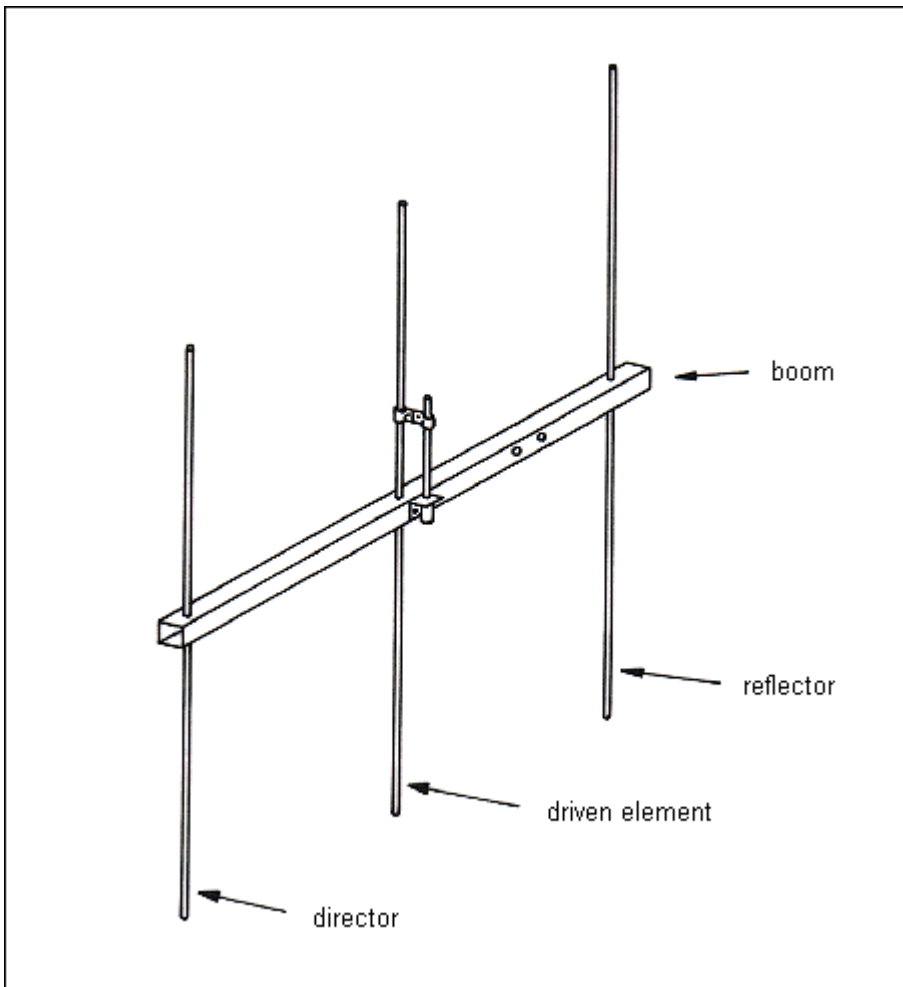

Figure 16.1 Yagi antenna model YG-23

Materials List

Quantity	Specification/Description	Dimensions
1	Aluminum tube 3/8" od*	3 feet 4"
1	Aluminum tube 3/8" od*	3 feet 2-3/16"
1	Aluminum tube 3/8" od*	3 feet 7/8"
1	Aluminum square channel	1" x 1" x 2 feet and 32-1/4"

Other materials used in constructing the antenna DP-2 are also needed for this yagi antenna except for the mounting channel.

* od - outside diameter

Construction

Cut the three tubes to their exact lengths and drill a hole (1/8" diameter) thru and thru at its middle length. The shortest tube will be used as a **director** element, the longest tube will be the **reflector** element and the medium length will be the **driven** element (see Figure 16.2).

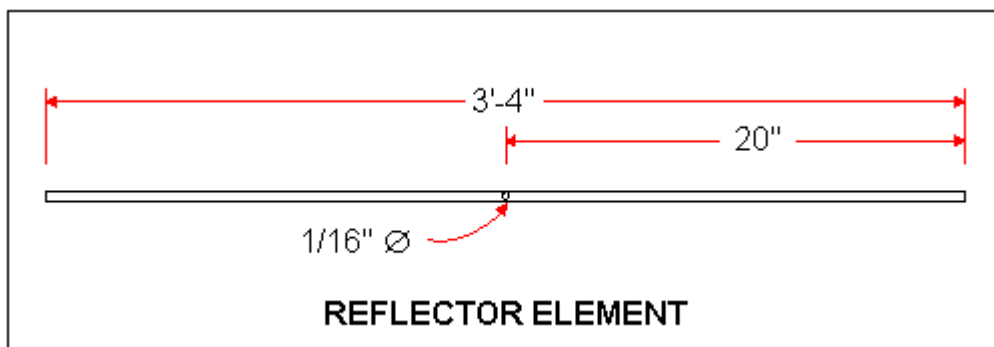

Figure 16.2 Preparing the reflector element.

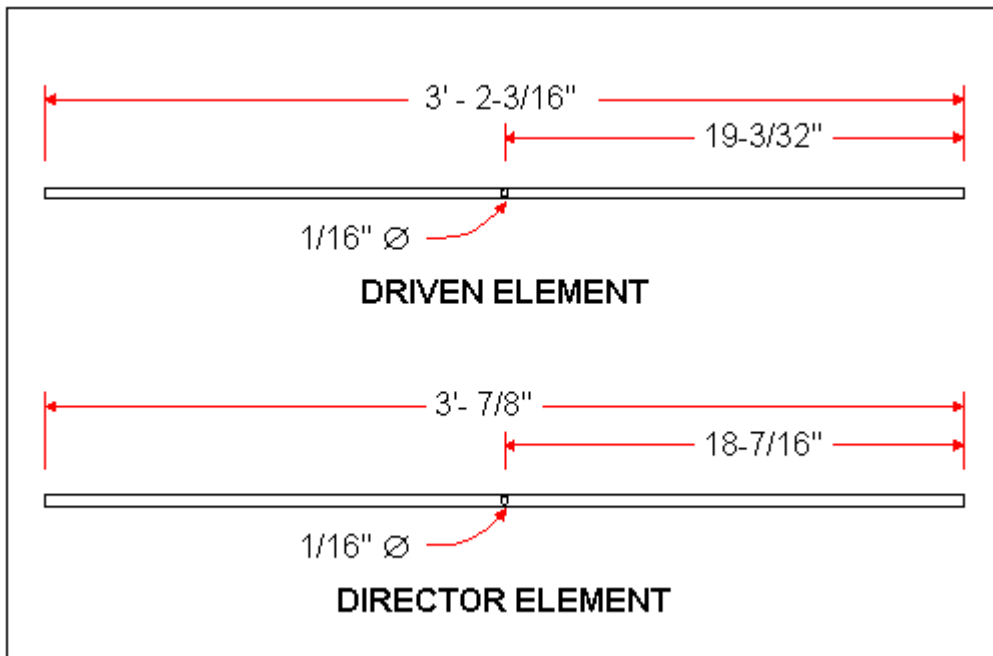

Figure 16.3 Preparing the driven and director elements.

Cut the aluminum mounting tube or boom to 2 feet and 11 inches long and drill three holes thru and thru at one side. The holes must have a diameter of 3/8" or enough to accommodate the diameter of the tube that will be inserted into it. Follow the dimensions shown. Drill also three 3/8" diameter holes at the same point where the larger holes are but at one side. The axis of the smaller holes must cross the axis of the larger holes (see Figure 16.4).

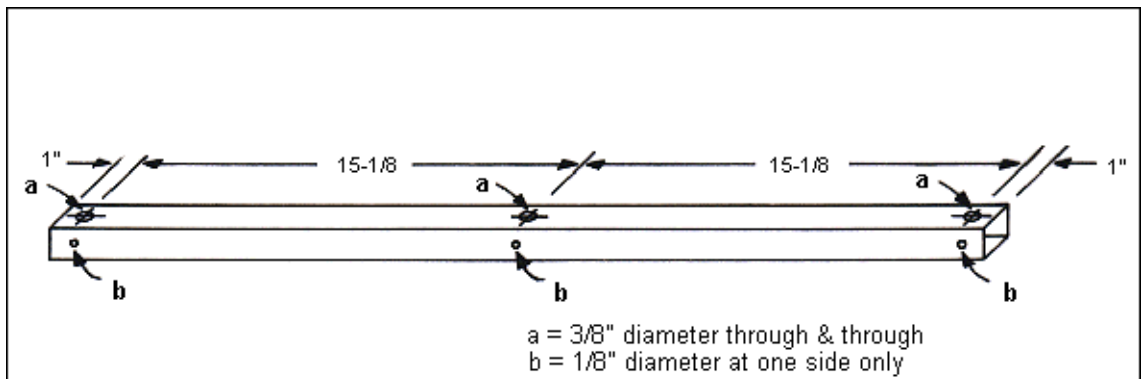

Figure 16.4 Preparing the boom.

Insert the aluminum tubes to the boom following the illustration for the proper arrangement of the elements. Secure the tube to the boom by placing the screws through the holes at the sides similar to the method of attaching the dipole element of the antenna model DP-2 (see Figure 16.5).

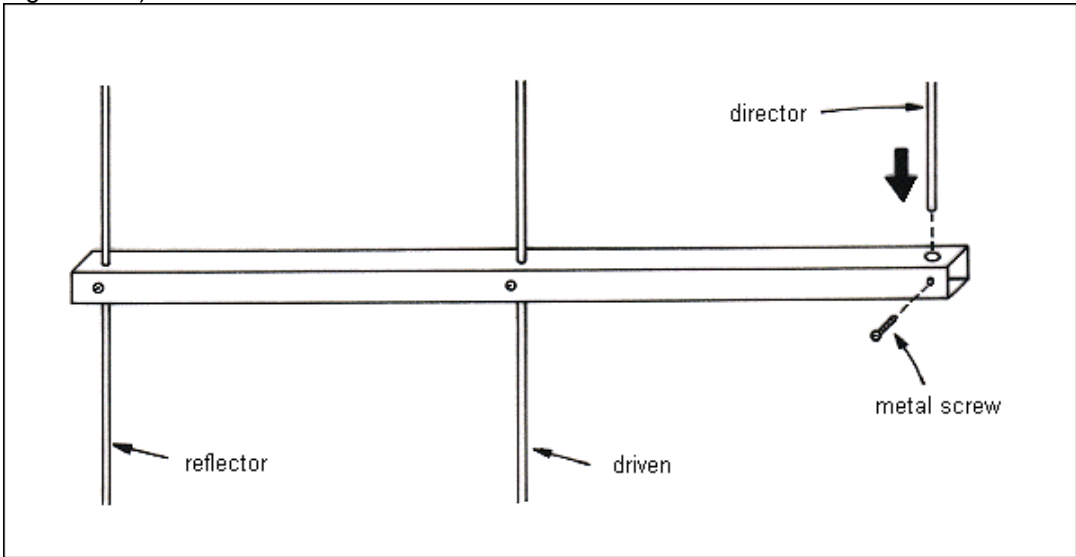

Figure 16.5 Assembling the antenna elements to the boom.

Complete the attachments of the **driven** element following the procedures described for model DP-2. All other materials and dimensions (e.g. gamma, bracket, connector, clamp, etc.) are similar to those used for the dipole elements of DP-2 (see Figure 16.6).

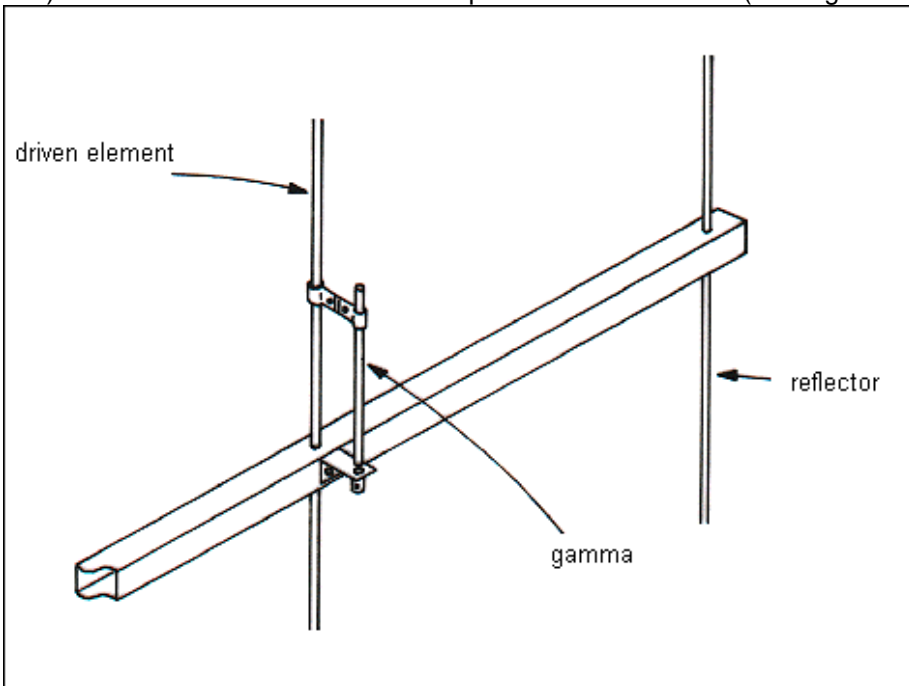

Figure 16.6 Complete assembly of the driven element.

Installation of YG-23

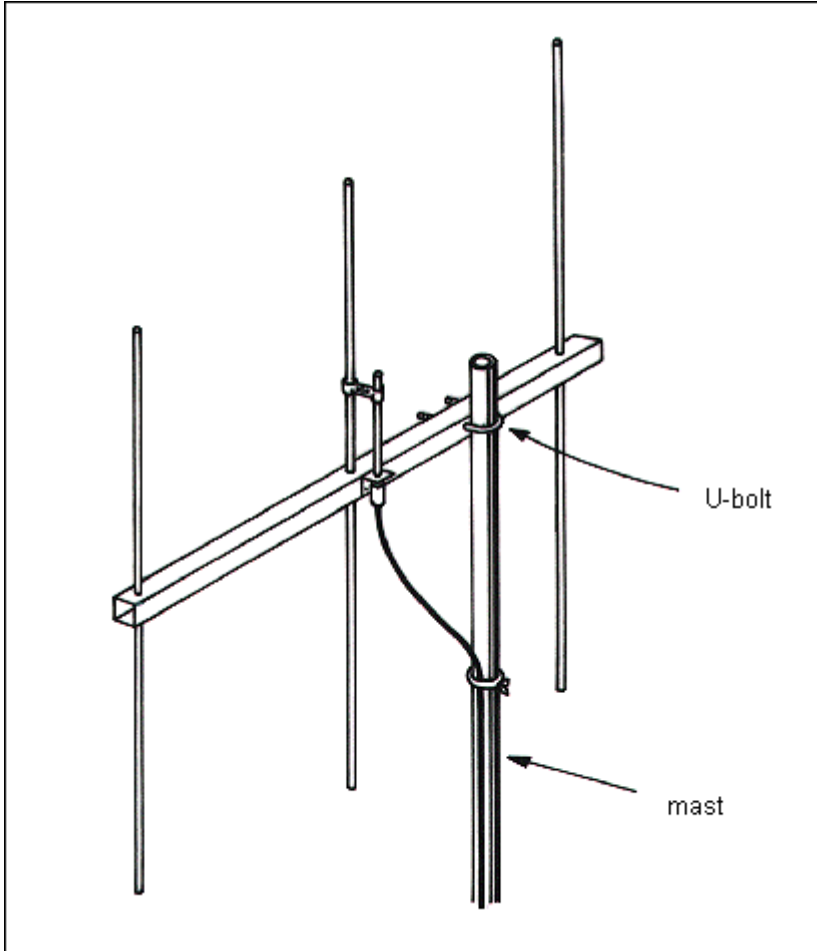

Figure 16.7 Installing the YG-23 to the mast.

Tuning YG-23 to resonance

The tuning procedure for the antenna model YG-23 is similar to the procedure for tuning antennas model DP-2, SD-22 or SD-24. The most important instruction to keep in mind is to tune the antenna while directly attached to the mast where it will be permanently installed whenever practical.

17 MULTI-ELEMENT YAGI-UDA ANTENNA ARRAY

The Yagi-Uda antenna or simply 'yagi' model YG-23 described in the preceding chapter gives a fairly high gain figure in a very compact and easy to construct antenna. By adding more director elements at the front and extending the boom length of the yagi, you can achieve a very high gain figure from this type of antenna.

The following table shows the exact element lengths and dimensions for various yagi antennas based on the NBS standard. Two sets of dimensions are given, one set for the type of yagi antenna with elements that are insulated from the boom and another set for the yagi antenna with elements directly attached to the metal boom. The latter is widely popular among the antenna constructors because it is easier to construct and eliminates the need for individual insulators.

The construction of the reflector, driven element, gamma match, director elements, assembly of the whole antenna and tuning procedures are basically the same with the model YG-23.

NBS YAGI STANDARD DIMENSIONS

Boom Length	Boom Diameter	Element Diameter	Insulated Elements	Reflector	Driven	Dir.1	Dir.2	Dir.3	Dir.4	Dir.5
5'5-9/16" (0.8λ)	1"	3/8" od*	YES	3'4"	3'2-3/16"	3"7/8"	3'11/16"	3' 7/8"	-	-
			NO	3'4-5/8"	-do-	3'1-1/2"	3'1-3/8"	3'1-1/2"	-	-
8'2-5/16" (1.2λ)	1"	3/8" od*	YES	3'4"	-do-	3' 7/8"	3'7/16"	3'7/16"	3'7/8"	-
			NO	3'4-5/8"	-do-	3'1-1/2"	3'1-1/8"	3'1-1/8"	3'1-1/8"	-
15'1/4" (2.2λ)	1-1/2"	3/8" od*	YES	3'4"	-do-	3'1-1/8"	3'5/16"	2'11-13/16"	2'11-1/4"	2'10-9/16"
21'10-1/16"(3.2λ)	1-1/2"	3/8" od*	YES	3'4"	-do-	3'7/8"	3'9/16"	2'11-3/4"	2'11-1/8"	2'10-7/8"
			NO	3'5-1/16"	-do-	3'1-15/16"	3'1-3/8"	3'13/16"	3'3/16"	3'
28'8-1/8" (4.2λ)	1-1/2"	3/8" od*	YES	3'3-3/8"	-do-	3'9/16"	3'9/16"	3'3/8"	2'11-5/8"	2'11-1/2"
			NO	3'4-1/2"	-do-	3'1-5/8"	3'1-5/8"	3'1-7/16"	3'11/16"	3'9/16"

Dir. 6	Dir. 7	Dir. 8	Dir. 9	Dir. 10	Dir. 11	Dir. 12	Dir. 13	Dir. 14	Dir. 15
-	-	-	-	-	-	-	-	-	-
-	-	-	-	-	-	-	-	-	-
-	-	-	-	-	-	-	-	-	-
-	-	-	-	-	-	-	-	-	-
2'10-9/16"	2'10-9/16"	2'10-9/16"	2'11-1/4"	2'11-13/16"	-	-	-	-	-
2'11-3/8"	2'11-3/8"	2'11-3/8"	3'	3'5/8"	-	-	-	-	-
2'10-9/16"	2'10-5/16"	2'10-5/16"	2'10-5/16"	2'10-5/16"	2'10-5/16"	2'10-5/16"	2'10-5/16"	2'10-5/16"	2'10-5/16"
2'11-5/8"	2'11-3/8"	2'11-3/8"	2'11-3/8"	2'11-3/8"	2'11-3/8"	2'11-3/8"	2'11-3/8"	2'11-3/8"	2'11-3/8"
2'11-1/8"	2'10-13/16"	2'10-9/16"	2'10-9/16"	2'10-9/16"	2'10-9/16"	2'10-9/16"	2'10-9/16"	-	-
3'3/16"	2'11-7/8"	2'11-5/8"	2'11-5/8"	2'11-5/8"	2'11-5/8"	2'11-5/8"	2'11-5/8"	-	-

* od - outside diameter

ELEMENT SPACING WITH RESPECT TO BOOM LENGTH

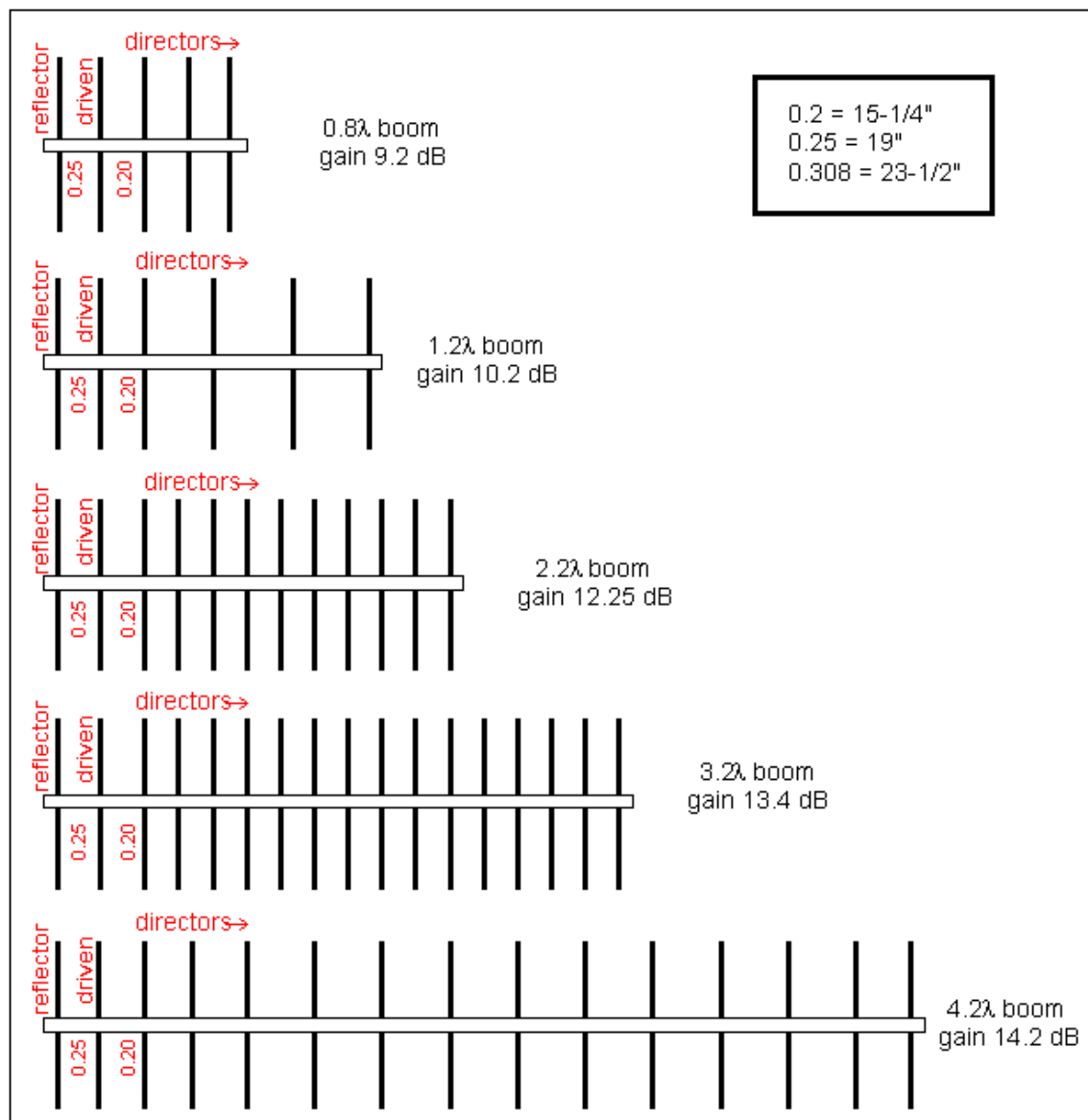

Figure 17.1 Element spacing of a Yagi antenna with respect to its boom length.

18 STACKING YAGI ANTENNAS

Stacking yagi antennas means multiplying the number of yagi antennas and feeding them all simultaneously. If a number of the yagi antennas is doubled, it will add an additional 3 dB to the original gain figure of the yagi. For example, if you feed two identical 3-element yagi which has a gain of 7.3 dB, it will give you a total gain figure of 10.3 dB. Similarly, a 17-element yagi with a gain of 13.4 dB will give a whooping 19.4 dB if stacked to four identical pieces!

In stacking yagis, the spacing between the antennas is important. The distance between two yagis stacked side by side must not be less than 1 wavelength or it must be approximately 77 inches. The distance between the tips of the elements in vertically stacked yagis must not be less than one-half wavelength or it must be approximately 38 inches (see Figures 18.1 and 18.2).

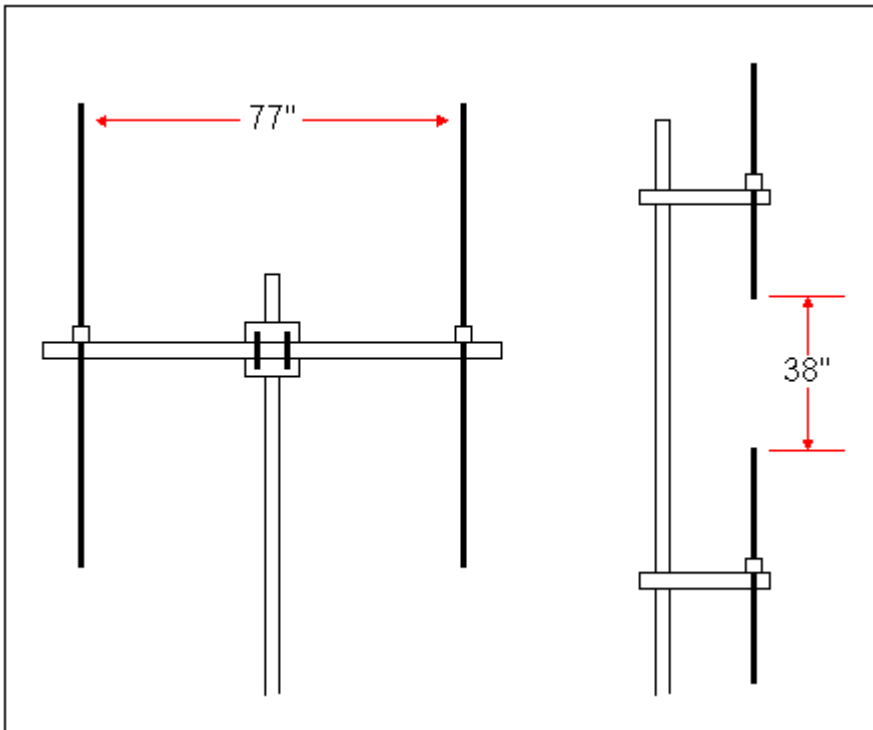

Figure 18.1 2 stacked yagis viewed at their boom ends.

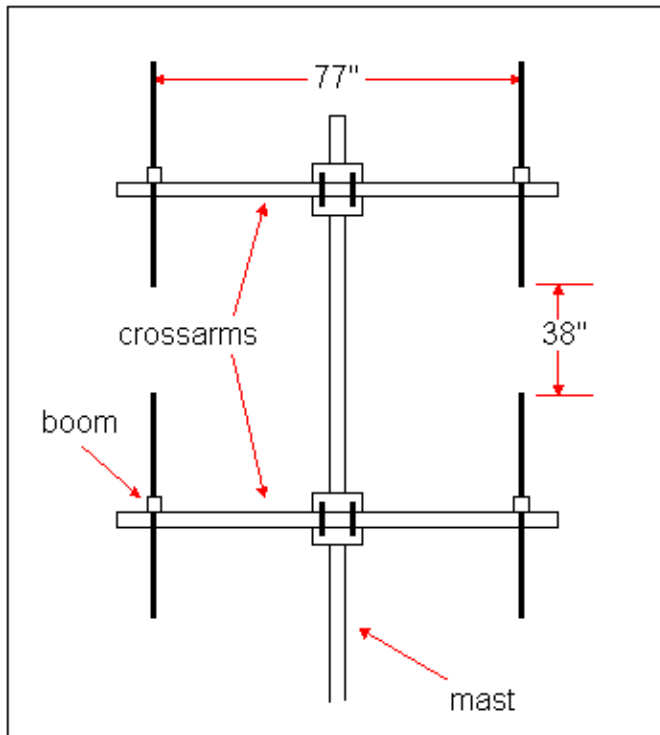

Figure 18.2 4 stacked yagis viewed at their boom ends.

All the yagis must be fed in phase with a phasing harness. For example, the configuration of a phasing harness for the 4 stacked yagis shown above is described in the following illustration.

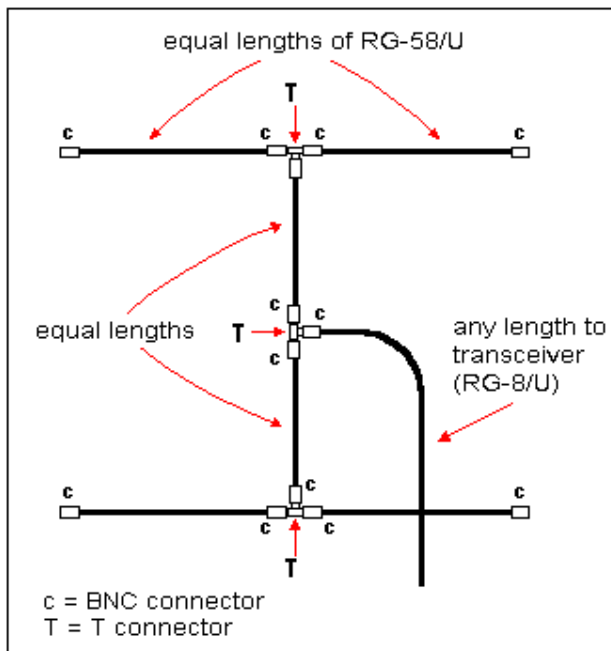

Figure 18.3 Phasing harness for a 4-stacked yagi antenna.

Mechanical Construction

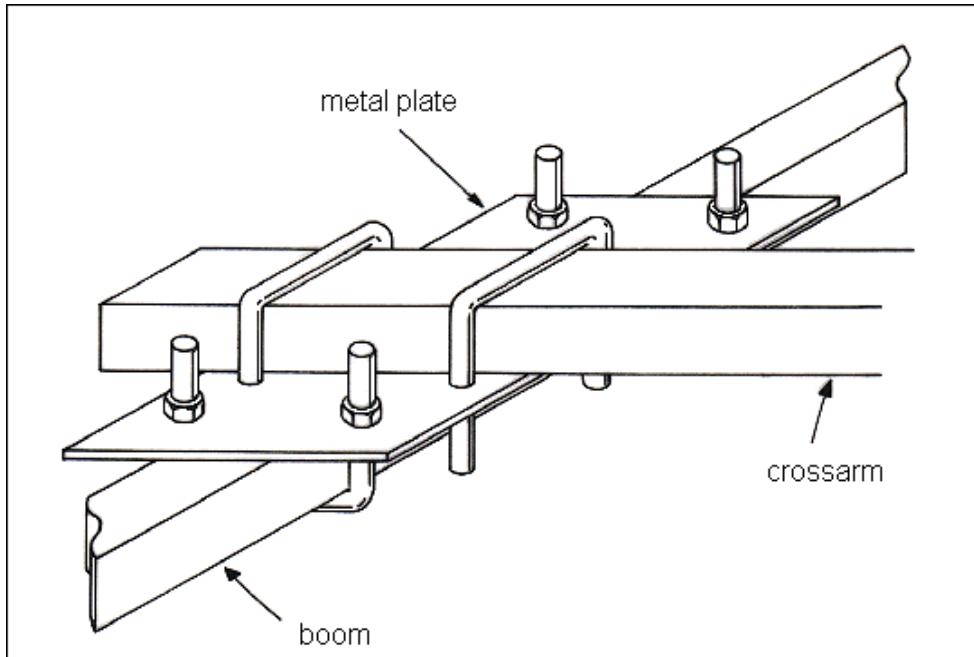

Figure 18.4 Attachment of the boom to cross-arm.

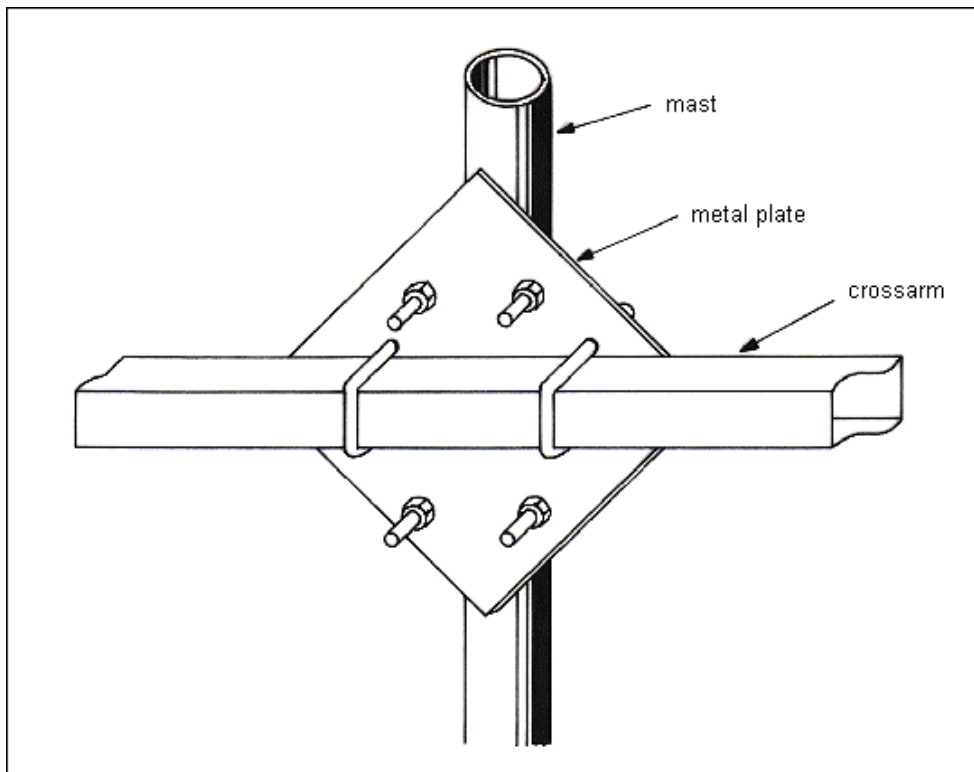

Figure 18.5 Attachment of the cross-arm to mast.

19

FORMULAS FOR CONVERTING ANTENNA DESIGNS FOR OTHER FREQUENCY BANDS

The dimensions of the antenna elements are generally derived from the antenna's electrical wavelength. **The electrical wavelength of a certain frequency is slightly different from its wavelength in free space**, where the former is the wavelength of the signal present in the **physical** conductor of the antenna and is somewhat shorter.

The formula to get the electrical wavelength of a frequency is:

In feet:

$$\frac{936}{F_C \text{ (MHz)}} = \lambda \text{ (feet)}$$

In meters:

$$\frac{286}{F_C \text{ (MHz)}} = \lambda \text{ (meters)}$$



F_C is the center frequency of the band expressed in Megahertz.



Lambda λ is the symbol for the wavelength expressed either in feet or meters depending on the particular units used.

■ For example, the wavelength of 145 MHz is:

$$\frac{936}{145} = 6.46 \text{ feet or } 77.52 \text{ inches}$$

Other symbols of wavelength:

$$\lambda/2 \text{ or } (0.5)\lambda = \text{halfwavelength}$$

$$\lambda/4 \text{ or } (0.25)\lambda = \text{quarterwavelength}$$

Groundplane elements

The formula to get the length of each element of a groundplane antenna is:

$$\mathbf{E \text{ (feet)} = \frac{468}{F_c}} \quad \text{or} \quad \mathbf{E \text{ (feet)} = 0.25 \lambda}$$

- To convert **E** (feet) to inches multiply it with 12.

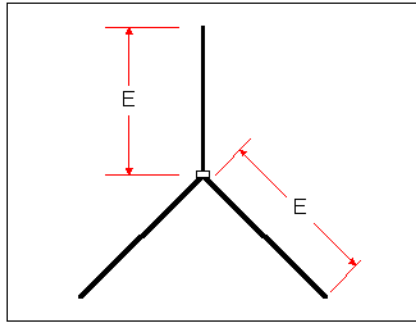

- **Example:** Find the length of one groundplane element intended for 220 MHz.

Solution:

$$\mathbf{E \text{ (feet)} = \frac{468}{220}} \quad \textit{substituting the value of frequency}$$

$$\mathbf{E \text{ (feet)} = \frac{2.127}{2}}$$

$$\mathbf{E \text{ (feet)} = 1.06} \quad \textit{this is the length of the element expressed in feet}$$

To convert the result to inches:

$$\mathbf{E \text{ (feet)} \times 12 = \mathbf{E \text{ (inches)}}$$

$$1.06 \times 12 = 12.72$$

$$\mathbf{E = 12.72 \text{ inches}} \quad \textit{this is the length of the element expressed in inches}$$

Coaxial dipole elements

Formulas to find the elements of a coaxial dipole:

$$E \text{ (feet)} = \frac{468}{F_c} \quad \text{or} \quad E \text{ (feet)} = 0.25 \lambda$$

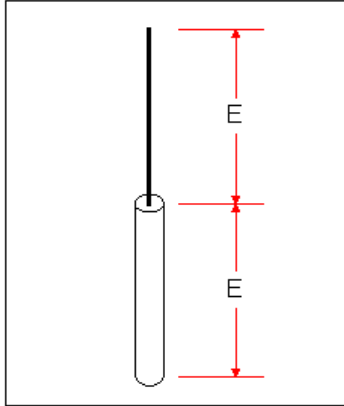

- **Example:** Find the length of the element for a coaxial dipole intended for 110 MHz (also known as aircraft band).

Solution:

$$E \text{ (feet)} = \frac{468}{F_c}$$

$$E \text{ (feet)} = \frac{468}{110}$$

substituting the value of frequency

$$E = 2.125 \text{ feet}$$

this is the length of the coaxial element expressed in feet

Convert the result to inches:

$$E \text{ (feet)} \times 12 = E \text{ (inches)}$$

$$2.125 \times 12 = 25.5$$

$$E = 25.5 \text{ inches}$$

this is the final value expressed in inches

Quad loop antenna element

The formula to get the length of each side of the loop element for the Quad loop antenna:

$$S \text{ (feet)} = \frac{486}{F_c}$$

or

$$S \text{ (feet)} = \frac{0.25 \lambda}{2}$$

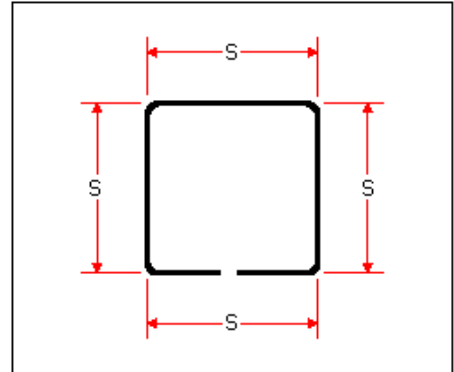

- **Example:** Find the length of one side of the quad loop intended for 155 MHz (VHF commercial band).

Solution:

$$S \text{ (feet)} = \frac{486}{F_c}$$

$$S \text{ (feet)} = \frac{486}{155}$$

$$S \text{ (feet)} = \frac{3.02}{2}$$

$$S = 1.51 \text{ feet}$$

substituting the value of frequency

this is the length of one side of the loop element expressed in feet

Convert the result to inches:

$$S \text{ (feet)} \times 12 = S \text{ (inches)}$$

$$1.51 \times 12 = 18.12$$

$$S = \mathbf{18.12 \text{ inches}}$$

this is the final value expressed in inches

Dipole element

The formula to get the length of the dipole element for the antennas DP-22, SD-22, and SD-24:

$$D \text{ (feet)} = \frac{486}{F_c} \quad \text{or} \quad D \text{ (feet)} = 0.5 \lambda$$

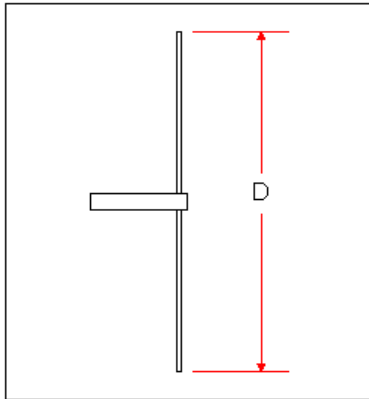

■ **Example:** Find the length of the dipole element intended for 195 MHz.

Solution:

$$D \text{ (feet)} = \frac{486}{F_c}$$

$$D \text{ (feet)} = \frac{486}{195}$$

$$D \text{ (feet)} = 2.4 \text{ feet}$$

this is the length of the dipole element expressed in feet

Convert the result to inches:

$$D \text{ (feet)} \times 12 = D \text{ (inches)}$$

$$2.4 \times 12 = 28.8$$

$$D = 28.8 \text{ inches}$$

this is the final value expressed in inches

Spacing between dipoles' ends

The formula to get the correct spacing between the ends of two dipoles in a collinear array such as SD-22 or SD-24:

$$\mathbf{S \text{ (feet)} = \frac{468}{F_c}} \quad \text{or} \quad \mathbf{S \text{ (feet)} = 0.25 \lambda}$$

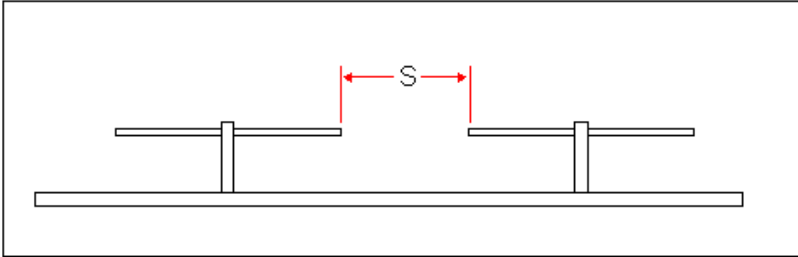

■ **Example:** Find the spacing between two dipoles designed for 220 MHz.

Solution:

$$\mathbf{S \text{ (feet)} = \frac{468}{F_c}}$$

2

$$\mathbf{S \text{ (feet)} = \frac{468}{220}}$$

2

$$\mathbf{S \text{ (feet)} = \frac{2.127}{2}}$$

$$\mathbf{S = 1.053 \text{ feet}}$$

this is the length of the dipole element expressed in feet

Convert the result to inches:

$$\mathbf{S \text{ (feet)} \times 12 = \mathbf{S \text{ (inches)}}$$

$$1.053 \times 12 = 12.45$$

$$S = 12.45 \text{ inches}$$

*this is the final value
expressed in inches*



NOTE:

This spacing is only for the minimum allowable between the ends of the dipole elements in a collinear antenna. Optimum spacing is within 0.25λ and 0.5λ .

Discone dimensions

To get the exact lengths and dimensions of the discone antenna, first compute the wavelength of the lowest targeted frequency by using this formula:

$$\lambda \text{ (wavelength in feet)} = \frac{936}{F_c}$$

Formulas for dimensions:

The disc element diameter is **0.19** of the wavelength.

The cone element length is **0.29** of the wavelength.

The spacing between the disc element and the apex of the cone element is **0.0077** of the wavelength.

The diameter of the mounting tube is not critical.

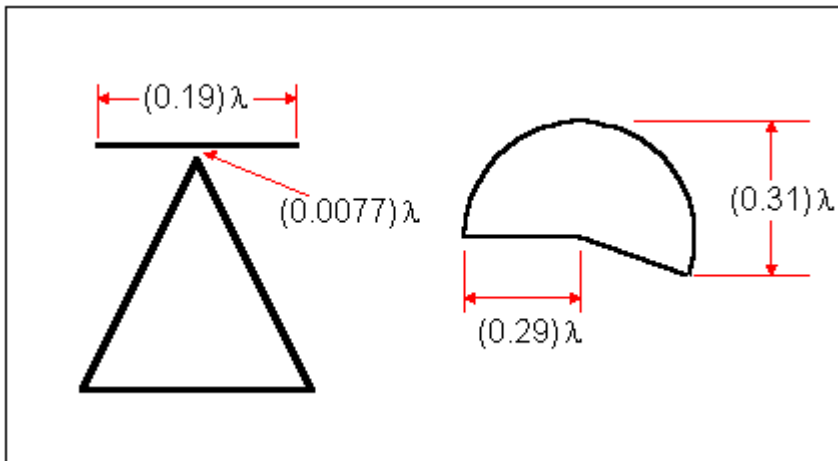

- Example:** Find the dimensions of a discone antenna with a cut-off frequency of 120 MHz (upper portion of the aircraft band).

Solution:

First find the wavelength of the frequency by using the formula below and convert the result to inches.

$$\frac{936}{F_c} = \lambda \text{ (wavelength in feet)}$$

$$\frac{936}{120} = 7.8$$

$$7.8 \text{ feet} = \lambda \quad \text{this is the wavelength of the frequency in feet}$$

Convert it to inches:

$$7.8 \times 12 = 83.6$$

$$\lambda \text{ (inch)} = \mathbf{83.6 \text{ inches}} \quad \text{wavelength of the frequency in inches}$$

From the result above you can proceed to compute the dimensions:

DISC ELEMENT DIAMETER:

$$\text{Formula: } 0.19 \times \lambda \text{ (inch)} = \text{disc diameter}$$

(substitute value of λ)

$$0.19 \times 83.6 = 15.384$$

$$\mathbf{15.382 \text{ inches}} \quad \text{diameter of the disc}$$

LENGTH OF CONE ELEMENT:

$$\text{Formula: } 0.29 \times \lambda \text{ (inch)} = \text{length of cone element}$$

(substitute value of λ)

$$0.29 \times 83.6 = 24.44$$

$$\mathbf{24.44 \text{ inches}} \quad \text{length of the cone element}$$

SPACING BETWEEN DISC AND CONE'S APEX:

Formula: $0.0077 \times \lambda$ (inch) = spacing

(substitute value of λ)

$$0.0077 \times 83.6 = 0.64$$

0.64 inches

*spacing between
disc and cone's apex*



NOTE:

In calculating the dimensions of a discone, you must always use the value of the lowest frequency you intend to operate (cut-off frequency).

5/8 Wave radiator element

The formula to get the length of the radiator element of a 5/8 element wavelength antenna such as in WA-2 and PF-2C:

$$L \text{ (feet)} = 0.65 \times \lambda$$

or

$$L \text{ (feet)} = \frac{5 \times \lambda}{8}$$

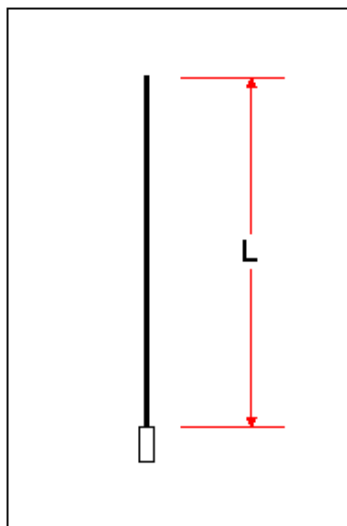

- **Example:** Find the length of the radiator element intended for 160 MHz (VHF commercial band).

Solution:

First find the wavelength of the center frequency by using the formula below and convert the result to inches.

$$\frac{936}{F_c} = \lambda \text{ (wavelength in feet)}$$

$$\frac{936}{160} = 5.85$$

$$5.85 \text{ feet} = \lambda \quad \textit{this is the wavelength of the frequency in feet}$$

Convert it to inches:

$$5.85 \times 12 = 70.2$$

$$\lambda \text{ (inch)} = \mathbf{70.2 \text{ inches}} \quad \textit{wavelength of the frequency in inches}$$

Finally, find the length of the 5/8 radiator element by using the following formula:

$$L \text{ (inch)} = 0.65 \times \lambda \text{ (inch)}$$

$$L \text{ (inch)} = 0.65 \times 70.2$$

$$L = 45.6 \text{ inches} \quad \textit{length of the radiator element}$$

APPENDIX

POWER RATIO TO DECIBEL CONVERSION

Ratio	Decimal Increments									
	0.0	0.1	0.2	0.3	0.4	0.5	0.6	0.7	0.8	0.9
1	0.00	0.41	0.79	1.14	1.46	1.76	2.04	2.30	2.55	2.79
2	3.01	3.22	3.42	3.62	3.80	3.98	4.15	4.31	4.47	4.62
3	4.77	4.91	5.05	5.19	5.32	5.44	5.56	5.68	5.80	5.91
4	6.02	6.13	6.23	6.34	6.44	6.53	6.63	6.72	6.81	6.90
5	6.99	7.08	7.16	7.24	7.32	7.40	7.48	7.56	7.63	7.71
6	7.78	7.85	7.92	7.99	8.06	8.13	8.20	8.26	8.33	8.39
7	8.45	8.51	8.57	8.63	8.69	8.75	8.81	8.86	8.92	8.98
8	9.03	9.08	9.14	9.19	9.24	9.29	9.34	9.40	9.44	9.49
10	10.00	10.04	10.09	10.13	10.17	10.21	10.25	10.29	10.33	10.37
x10	+10									
x100	+20									
x1000	+30									
x10,000	+40									
x100,000	+50									

How to use this chart:

The decibel value is read from the body of the table for the desired ratio, including the decimal increment. For example, a power ratio of 1.8 is equivalent to 2.55 dB. Value from the table may be extended as indicated at the lower left in each section. For example, a power ratio of 16 which is the same as 10 x 1.6 is equivalent to 10 + 2.04 = 12.04 dB.

Power loss in relation to the SWR figure in the transmission line:

SWR	Power lost in %
1 :1	0 %
1,3 :1	2 %
1,5 :1	3 %
1,7 :1	6 %
2 :1	11 %
3 :1	25 %
4 :1	38 %
5 :1	48 %
6 :1	55 %
10 :1	70 %

METRIC EQUIVALENTS

Most of the antenna dimensions described in this book are in English units. If the constructor wants to use the metric system, he can convert all the dimensions by using the following conversion guide:

English to Metric

Inch = 25.4 millimeters
Inch = 2.54 centimeters
Foot = 0.305 meter
Yard = 0.914 meter

Metric to English

Centimeter = 0.3937 inches
Meter = 39.37 inches
Meter = 3.28 feet
Meter = 1.094 yards

GLOSSARY OF ANTENNA TERMS

Actual ground	The point within the earth's surface where effective ground conductivity exists. The depth of this point varies with the frequency, the condition of the soil and the geographical region.
Antenna	An electrical conductor or array of conductors that radiates signal energy (transmitting) or collects signal energy (receiving).
Apex	The feedpoint region of a discone antenna.
Apex angle	The enclosed angle in degrees inside the cone element of a discone antenna and similar antennas.
Bandwidth	The group of frequencies where the antenna functions efficiently.
Band	A group of frequencies.
Coaxial cable	Any of the coaxial transmission lines that has the outer shield (either solid or braided) in the same axis as the inner or center conductor. The insulating material can be air, helium, or solid dielectric compounds.
Collinear array	A linear array of radiating elements (usually dipoles) with their axis arranged in a straight line. Popular in VHF and higher frequencies.
Conductor	A metal body such as tubing, rod or wires that permits current to travel continuously along its length.
Counterpoise	A wire or group of wires mounted close to ground, but insulated from ground, to form a low impedance, high capacitance path to ground. Commonly used at medium frequency and high frequency to provide an effective ground for an antenna.
Dielectrics	Various insulating materials used in antenna systems, such as found in insulators and transmission lines.
Dipole	An antenna that is split exactly at the middle for connection to a feedline. Usually a halfwavelength in dimension. Also called a doublet.

Directivity	The property of an antenna that concentrates the radiated energy to form one or more major lobes.
Director	A conductor placed in front of a driven element to cause directivity. Frequently used singly or in multiples with Yagi or cubical quad beam antennas.
Direct ray	Transmitted signal energy that arrives at the receiving antenna directly rather than being reflected from the ionosphere, ground or man made reflector.
Doublet	see Dipole
Driven array	An array of antenna elements which are all driven or excited by means of a transmission line.
Driven element	The radiator element of an antenna system. The element to which the transmission line is connected.
Efficiency	The ratio of useful output power to input power, determined in antenna systems by losses in the system, including in nearby objects.
Feeders	Transmission lines of assorted type that are used to route RF power from a transmitter to an antenna, or from an antenna to a receiver.
Feedline	see Feeders
Front to back	The ratio of radiated power off the front to the back of a directive antenna. A dipole would have a ratio of 1 for example.
Front to side	The ratio of radiated power between the major lobe and the null side of a directive antenna.
Gain	Increase in effective radiated power in the desired direction of the major lobe.
Gamma match	A matching system used with driven antenna elements to effect a match between the transmission line and the feedpoint of the antenna. It consists of an adjustable arm that is mounted close to the driven element and in parallel with it near the feedpoint.
Groundplane	A man made system of conductors placed below an antenna to serve as an earth ground.
Groundscreen	A wire mesh groundplane.

Impedance	The ohmic value of an antenna feedpoint, matching section or a transmission line. An impedance may contain reactance as well as resistance components.
Lambda	Greek symbol for L used to represent a wavelength with reference to electrical dimensions in antenna work.
Line loss	The power lost in a transmission line, usually expressed in decibels.
Line of sight	Transmission path of a wave that travels directly from the transmitting antenna to the receiving antenna.
Load	The electrical entity to which the power is delivered. The antenna is a load for a transmitter. A dummy load is a nonradiating substitute for an antenna.
Loading	The process of transferring power from its source to a load. The effect of a load has on a power source.
Lobe	A defined field of energy that radiates from a directive antenna.
Matching	The process of effecting an impedance match between two electrical circuits of unlike impedance. One example is matching a transmission line to the feedpoint of an antenna. Maximum power transfer to the load (antenna system) will occur when a matched condition exists.
Null	A condition during which an electrical property is at minimum. The null in an antenna radiation pattern is that point in the 360 degree pattern where minimum field intensity is observed. An impedance bridge is said to be 'nulled' when it has been brought into balance.
Parasitic array	A directive antenna that has a driven element and independent directors or reflectors or both. The directors and reflectors are not connected to the feedline. A yagi antenna is one example. See also driven array.
Phasing lines	Sections of transmission line that are used to ensure correct phase relationship between the bays of an array of antenna. Also used to effect impedance transformations while maintaining the desired array phase.
Quad	Rectangular or diamond shaped fullwave loop antenna. Most often used with a parasitic loop director and a parasitic loop

reflector to provide approximately 8 dB of gain and good directivity. Often called the 'cubical quad'.

Radiation pattern	The radiation characteristics of an antenna as a function of space coordinates. Normally, the pattern is measured in the far field region and is represented graphically.
Radiator	A discrete conductor in an antenna system that radiates RF energy. The element to which the feedline is attached.
Reflector	A parasitic antenna element or a metal assembly that is located behind the driven element to enhance forward directivity. Large man made structures may reflect radio signals.
Source	The point of origination (transmitter or generator) of RF power supplied to an antenna system.
Stacking	The process of placing similar directive antennas atop or beside one another forming a 'stacked array'.
SWR	Standing wave ratio on a transmission line in an antenna system. More correctly, 'VSWR' or voltage standing wave ratio. The ratio of the forward to reflected voltage on the line and not the power ratio. A VSWR of 1:1 occurs when all parts of the antenna system are matched correctly to one another.
Velocity factor	That which affects the speed of radio waves in accordance to the dielectric medium they are in. A factor of 1 is applied to the speed of light and radio waves in free space, but the velocity is reduced in various dielectric mediums such as transmission lines. When cutting a transmission line to a specific electrical wavelength, the velocity factor of the particular line must be taken into account.
VSWR	Voltage standing wave ratio. See SWR.
Wave	A disturbance that is a function of time or space or both. A radio wave for example.
Wave front	A continuous surface that is the locus of points having the same phase at the same instant.

Yagi A directive, gain type of antenna that utilizes a number of parasitic directors and a reflector. Named after one of the inventors (Yagi and Uda).

BIBLIOGRAPHY

Source materials for more advanced study of the antenna designs presented in this book can be found in the following references:

Lytel, Allan. *ABC's of Antennas*, 1973

"Antenna Fundamentals", *The ARRL Antenna Book*, 14th ed., chap.2

Bergren, A.L. "The Multi-element Quad", *QST*, May 1963

Brown, "Directional Antennas", *Proc. I.R.E.*, January 1937

Brown, Lewis, and Epstein. "Ground Systems as a Factor in Antenna Efficiency", *Proc. I.R.E.*, June 1937

Carter. "Circuit Relations in Radiating Systems and Applications to Antenna Problems", *Proc. I.R.E.*, June 1932

Geiser, Dave. "The Discone - a VHF-UHF Tribander", *QST*, December 1978

Erhorn, P.C. "The Element Spacing in 3-element Beams", *QST*, October 1957

"Groundplane Antenna", *The ARRL Handbook*, 14th ed., chap.2

Jasik. *Antenna Engineering Handbook* (New York: Mcgraw Hill Book Co.)

Kraus. *Antenna* (New York: Mcgraw Hill Book Co.)

Laport. *Radio Antenna Engineering*, New York: Mcgraw Hill Book Co., 1952

"Omni-directional Antennas For VHF and UHF", *The ARRL Antenna Book*, 14th ed., chap. 11

"Portable and Mobile Antennas", *The ARRL Antenna Book*, 14th ed., chap. 13

Reynolds, F. "Simple Gamma Match Construction", *QST*, July 1957

Rumsey. *Frequency Independent Antennas*, New York: Academic Press, 1966

Terman. *Radio Engineering*, New York: Academic Press, 1966